



Society of Cable
Telecommunications
Engineers



Installation & Service 101





Society of Cable
Telecommunications
Engineers



Overview

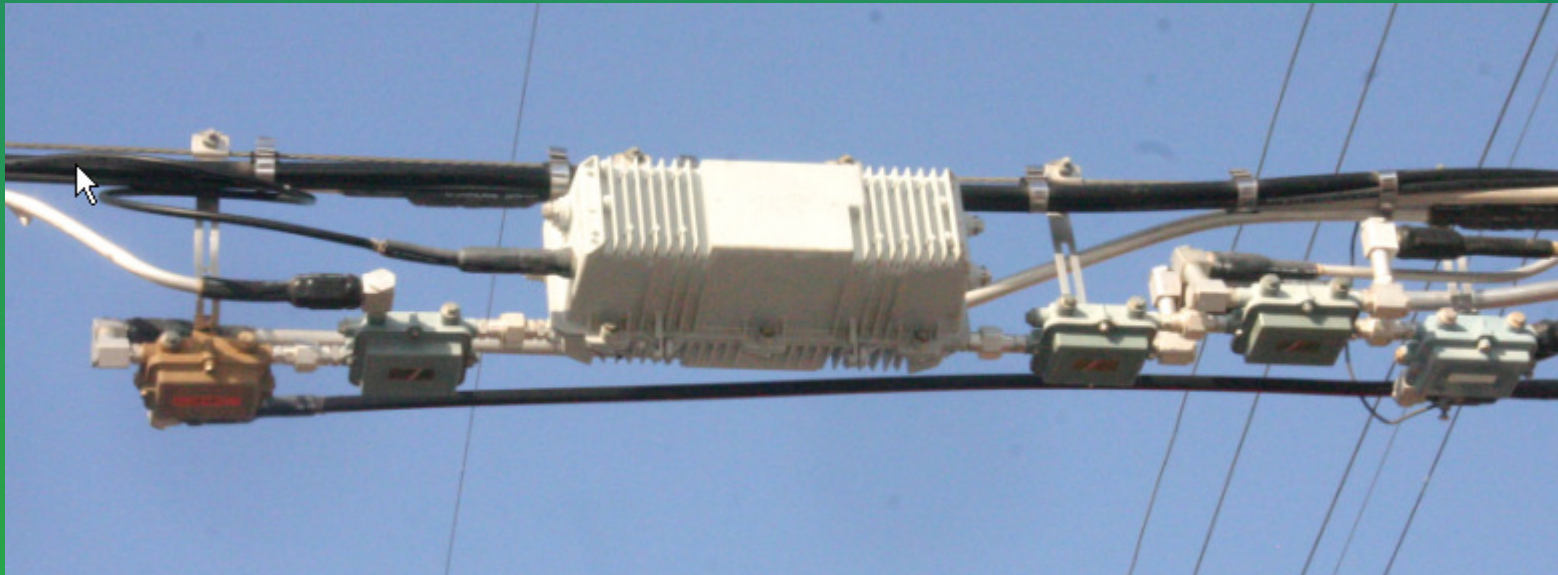



What to Learn

- CATV History
- How we receive the signals
- Components of the HFC Network
- Advantages of the HFC Network
- FTTx & Fiber Deep networks



Society of Cable
Telecommunications
Engineers



Where It All Started



A few years after World War II, John Walson, a Pennsylvania appliance store owner, placed an antenna on top of a local mountain and ran a cable down to his store and to a few of his customers' homes. By doing this, he created North America's first CATV – *Community Antenna Television*.

Where We Get the Signals

- Over-the-Air Broadcasts
- Local Feed
- Microwave
- Satellite

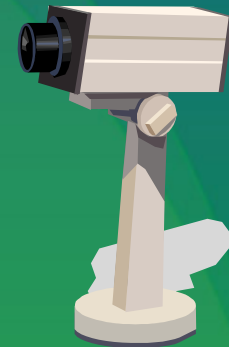



The Hybrid Fiber Coax Network

- This system replaces the trunk lines and amplifiers of the Tree and Branch Network with fiber optic cables and optical receivers
- The HFC system makes two directional signal flow possible which allows us to provide our customers with digital video, high-speed internet, and digital telephone services.

Fiber Components



Power Supply

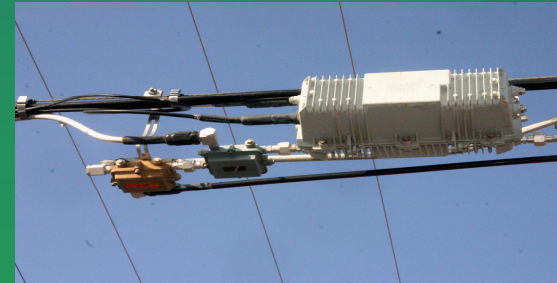

Node



Enclosure



Snowshoe

HFC

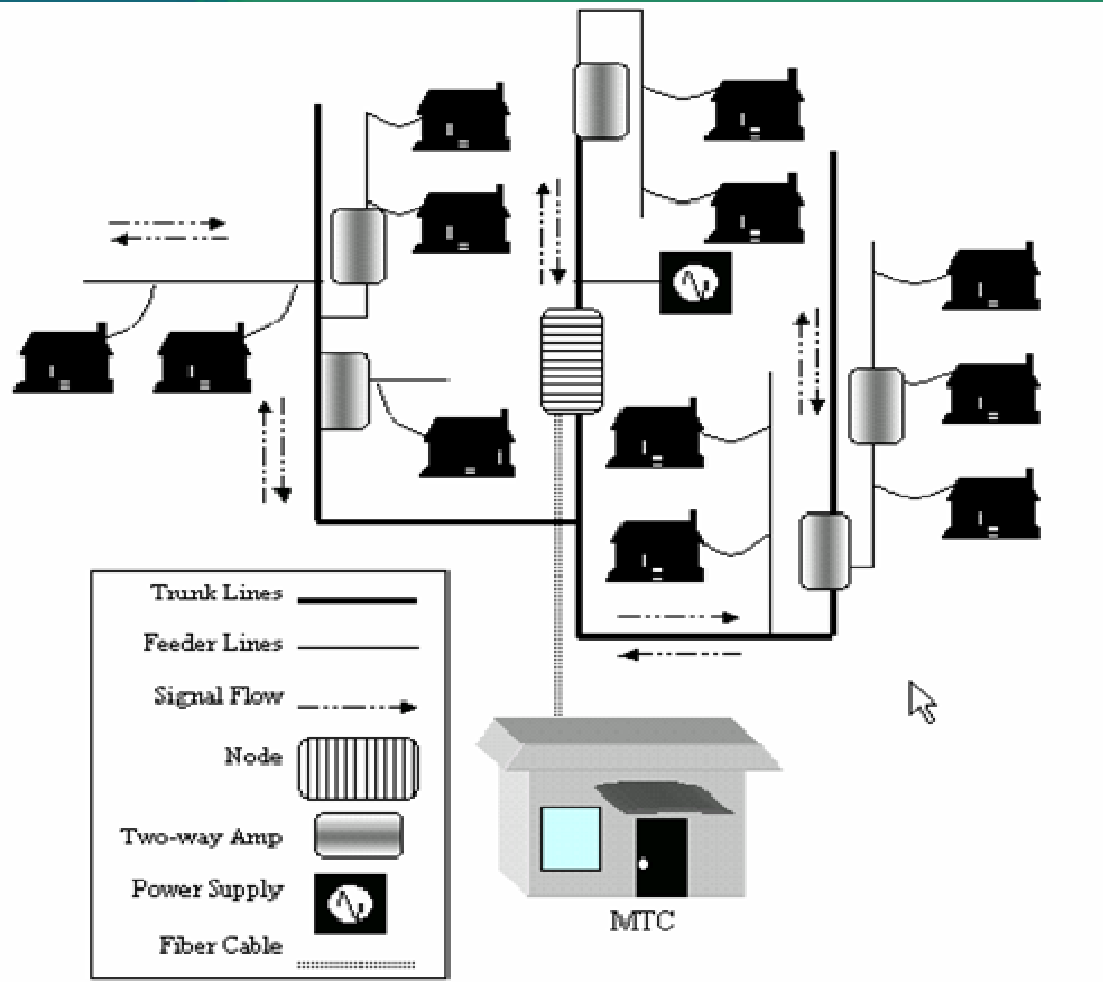

- Signals travel from the Headend over fiber to the node – a type of optical receiver.
- Unlike electrical signals over coax, optical signal can travel more than 40 miles over fiber without amplification.

The Node

- The node acts as a translator – it converts optical energy into electrical energy in the downstream direction and electrical energy into optical energy in the upstream direction.

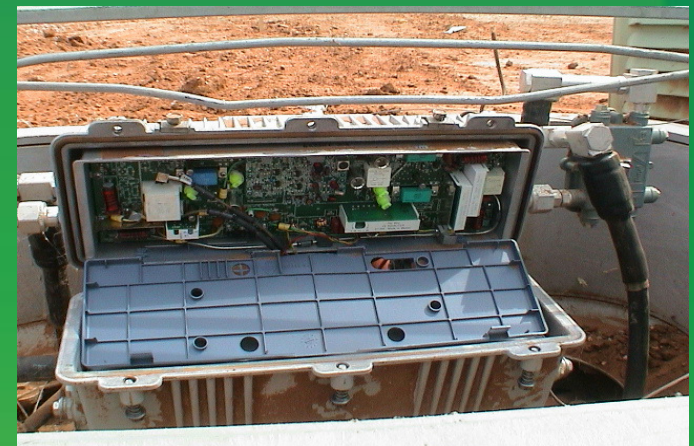
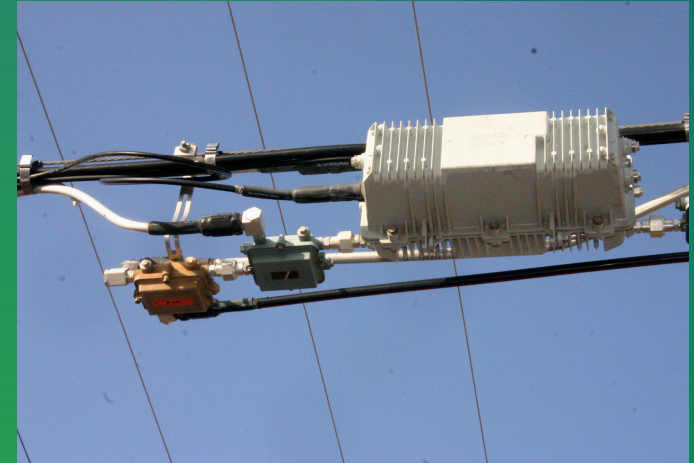

Redundancy

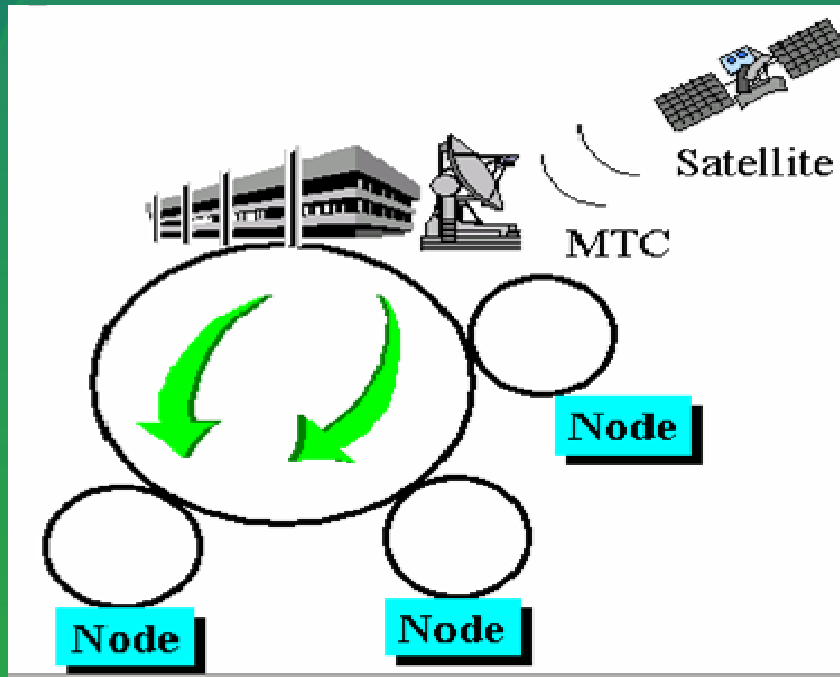

- One way to increase security and reliability in the HFC network is to create a redundant ring, sometimes called ring-in-ring architecture.
- A redundant ring can ensure uninterrupted service to all customers if there is a break in the fiber.

Fiber Deep

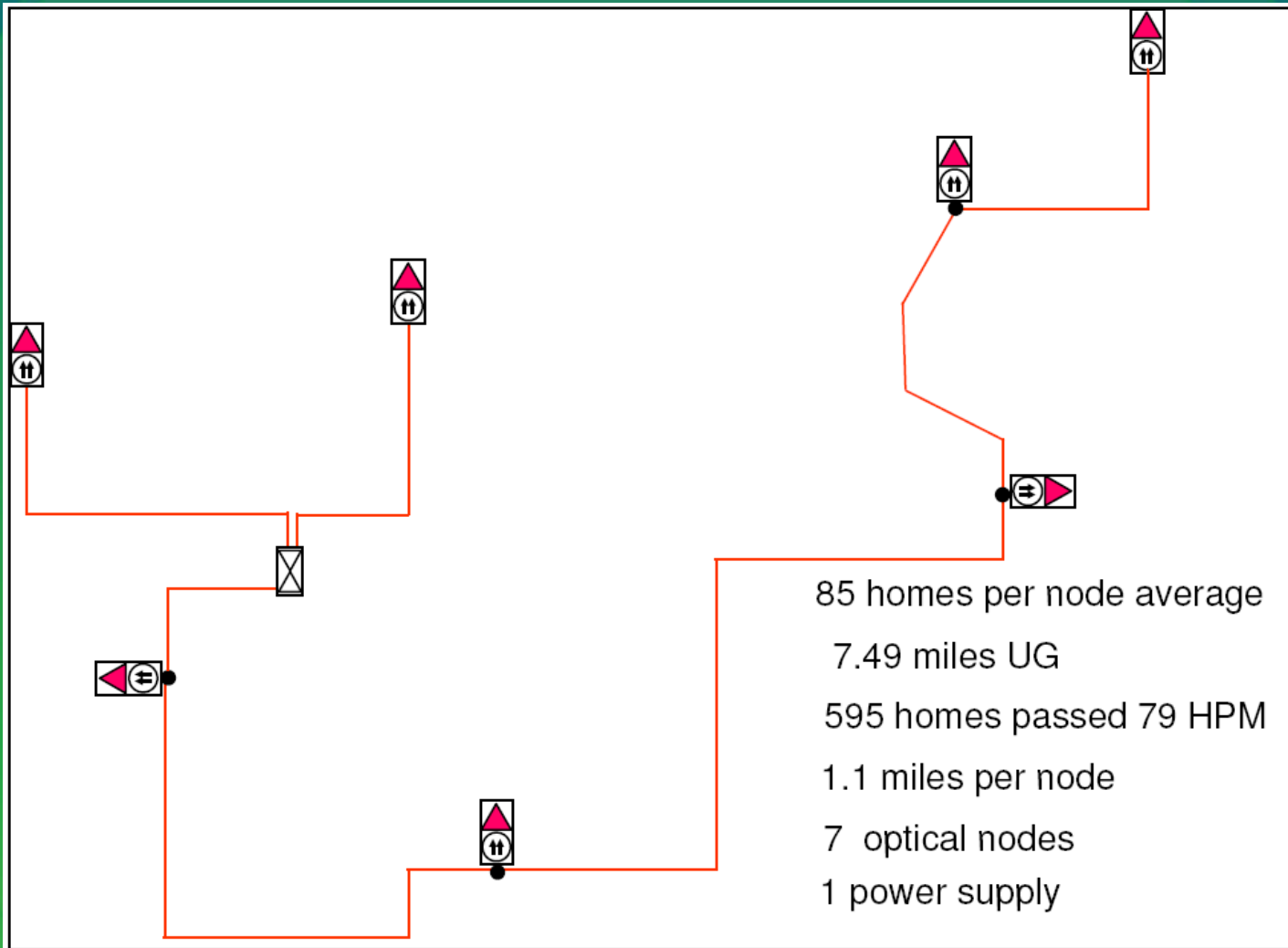



Society of Cable
Telecommunications
Engineers



FTTH

Fiber To The Home – Fiber optic network extends all the way to the side of the home. It still converts from Fiber to Coax at the NIU location.



Society of Cable
Telecommunications
Engineers



Passive & Active Devices

Basic Electrical Concepts in Cable



- Active Device: Anything that requires electricity in order to operate.

Node – Line Extender – House Amp

- Passive Device: Anything that does not require electricity in order to operate.

Tap – Directional Coupler – Splitter

Drop Amplifier Overview

- Common Drop Amplifier configurations:
 - Single output, 15 dB gain
 - Two output, 11 dB effective gain
 - Four output, 7 dB effective gain
 - Eight output, 4 dB effective gain
- **Do Not** use to compensate for a cable fault. **Input range: 3 – 8 dBmV**

Drop Amplifier Single Output

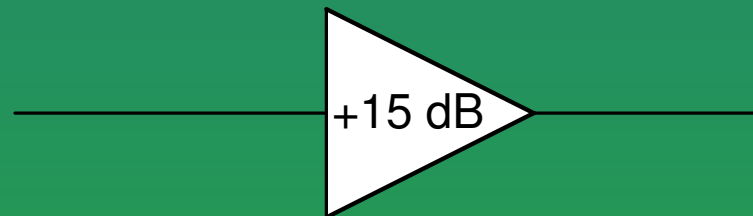

Forward Gain = 15 dB

Return Path Loss = Minimal



Society of Cable
Telecommunications
Engineers



Drop Amplifier Without Power Inserter

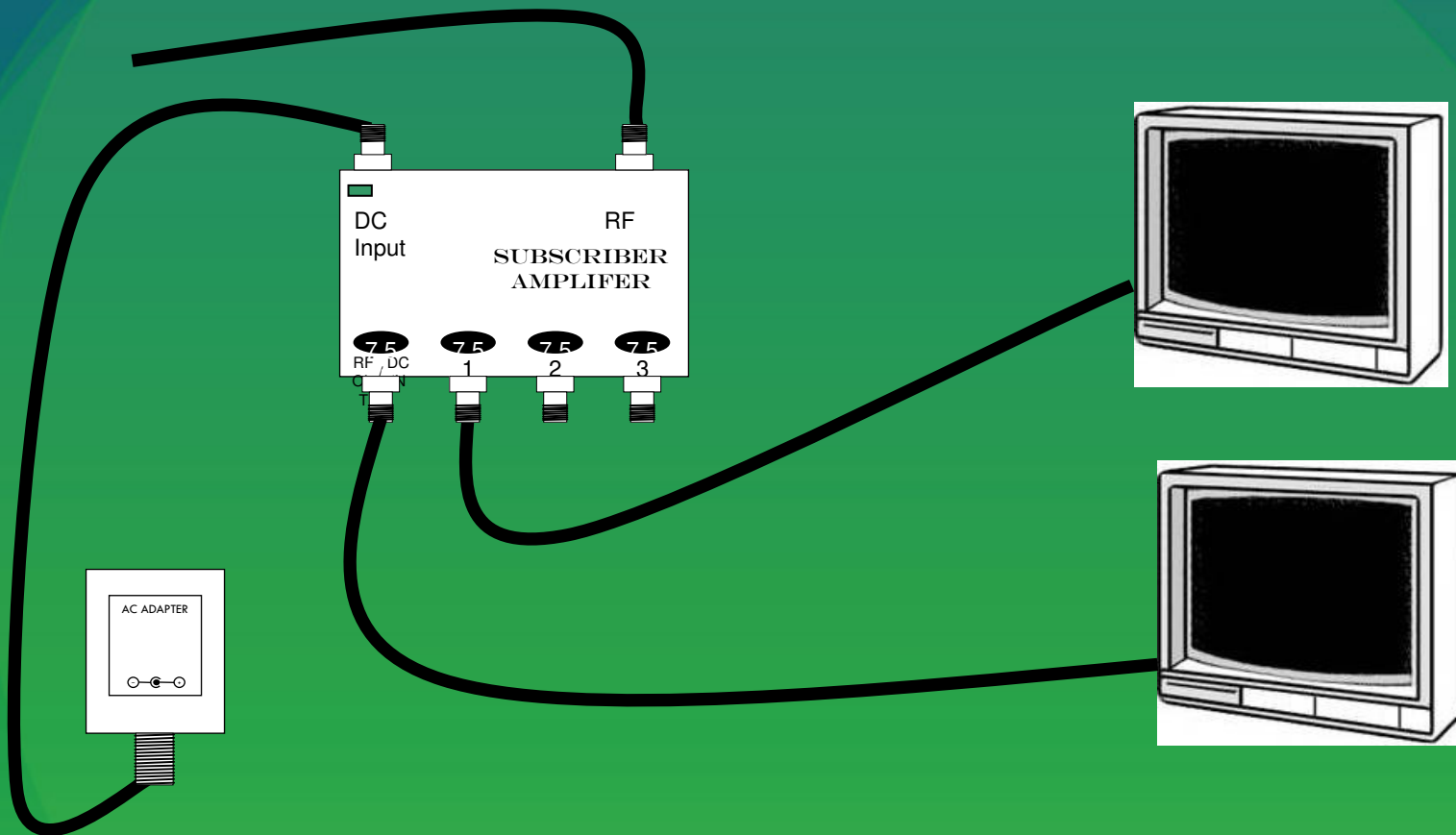

Drop Power Inserter

- Inserts power onto the drop to power the drop amplifier . . .

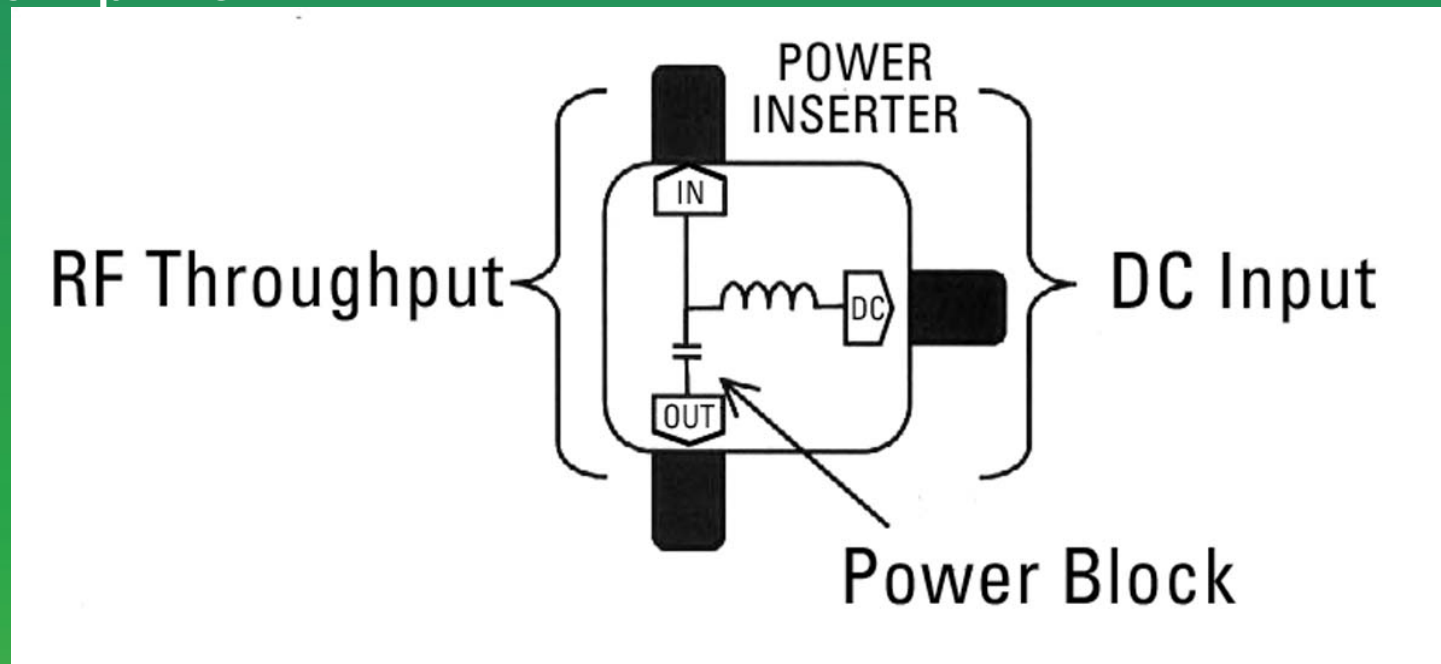

Drop Amplifier With Power Inserter

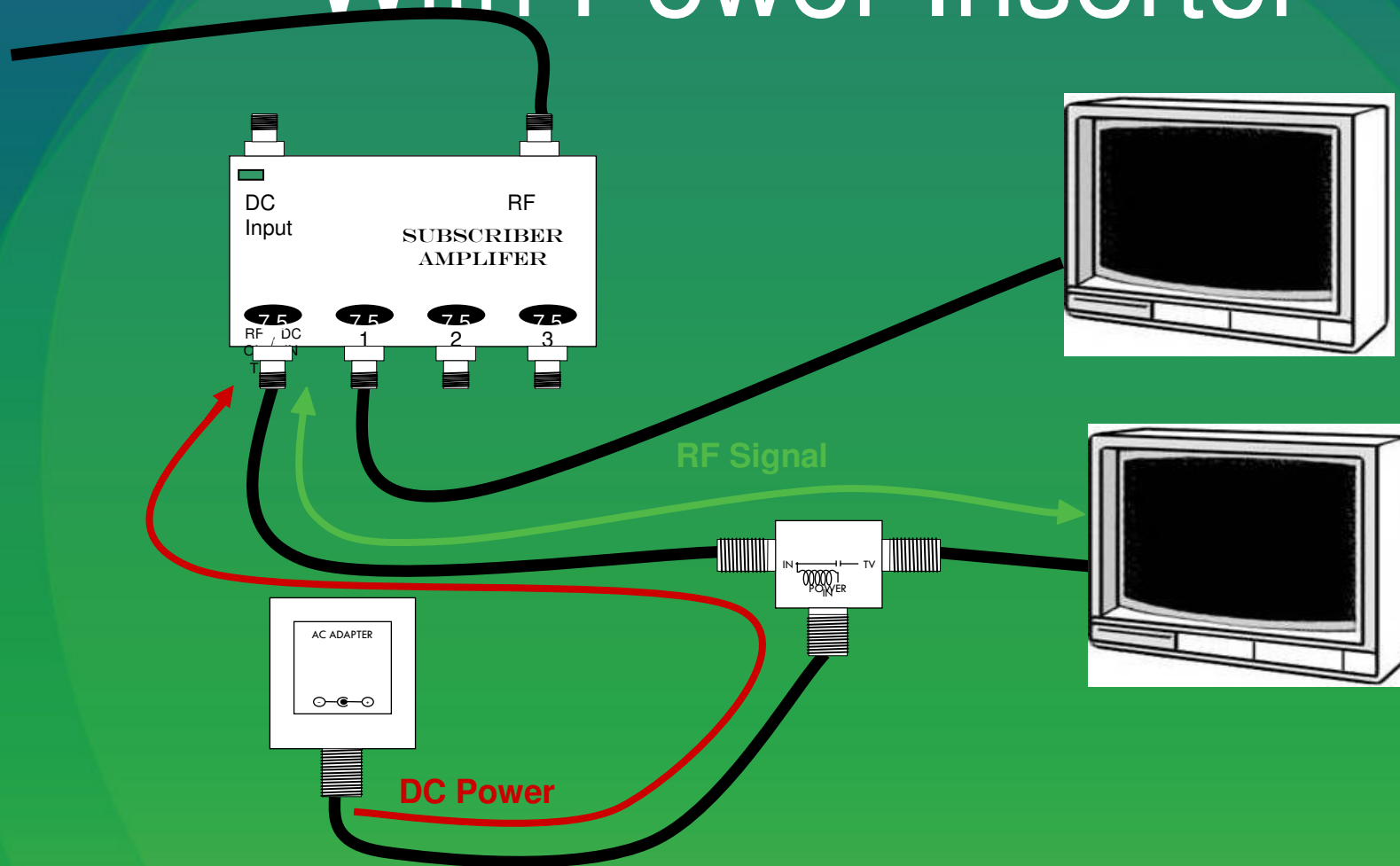

Passive Devices

Splitters – Insertion Loss

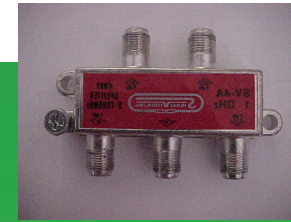
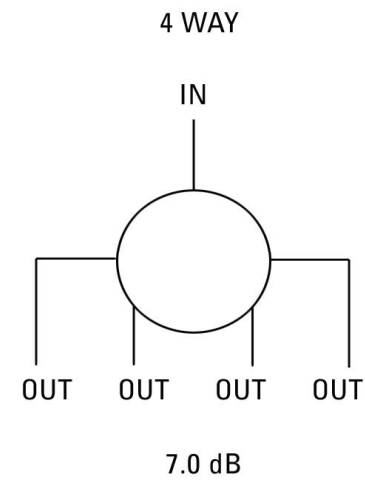
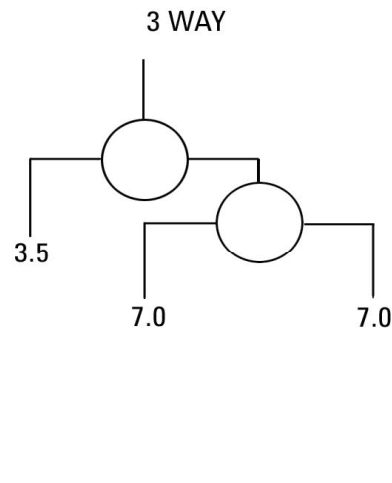
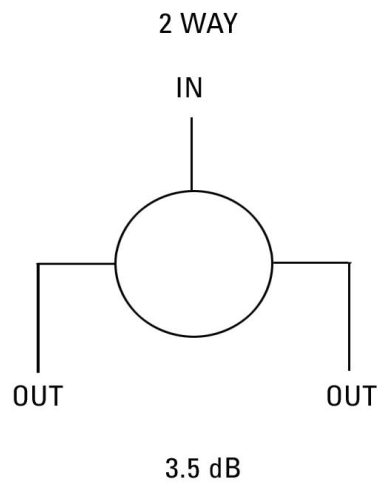

Insertion Loss : Loss In-Out

Passive Devices

Splitters – Isolation Loss

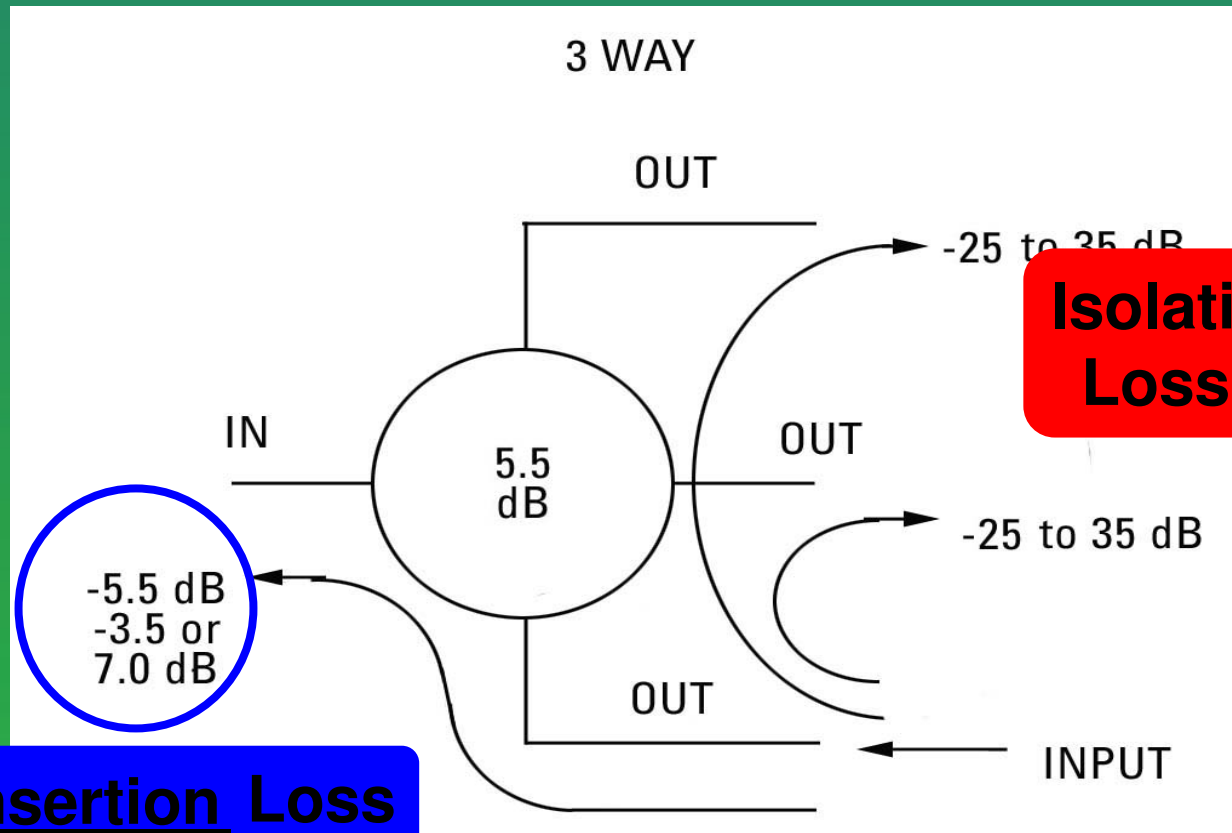

**Isolation Loss :
Loss Out-Out**

Insertion Loss

-5.5 dB
-3.5 or
7.0 dB

Backwards Splitter

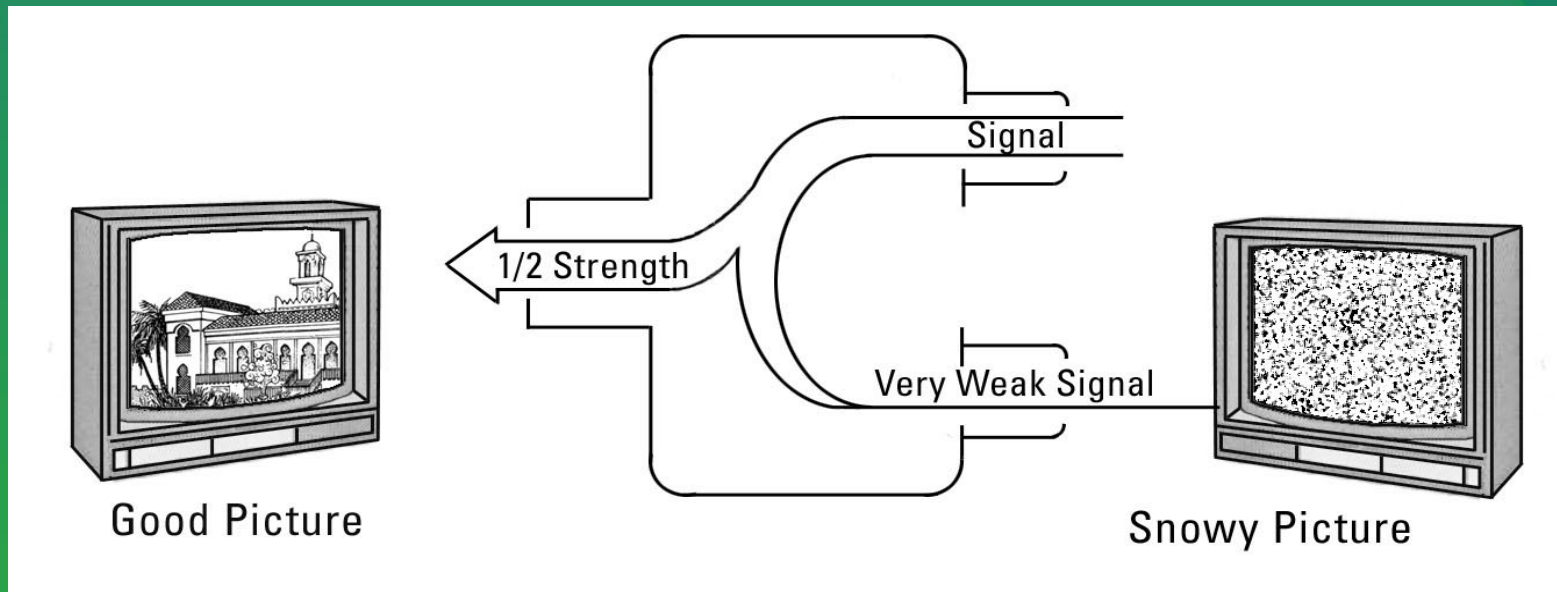

Passive Devices

Directional Couplers – Tap Loss

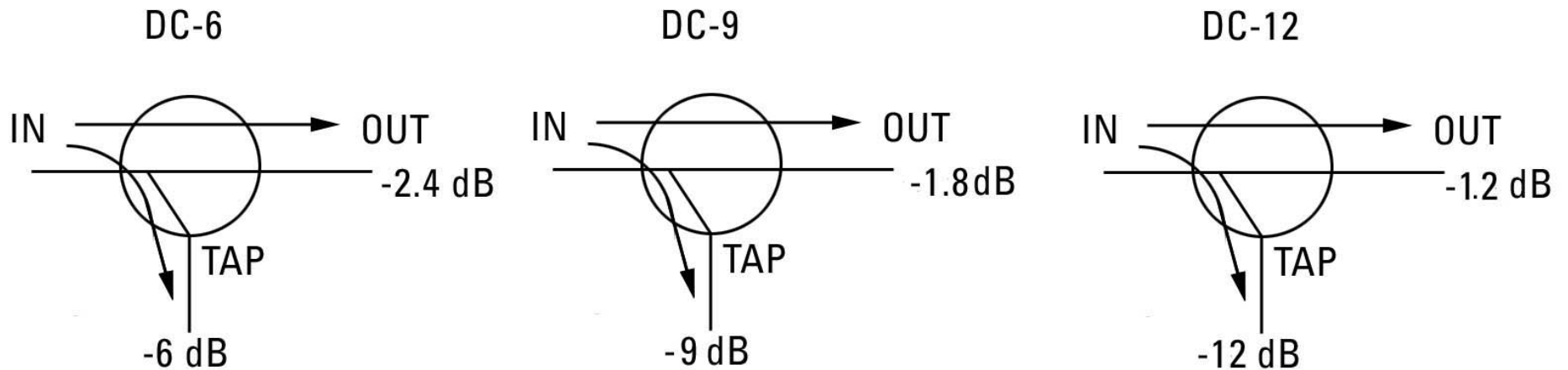

Tap Loss : Loss In-Tap

Passive Devices

DC – Isolation Loss

**Insertion Loss :
Loss In-Out**

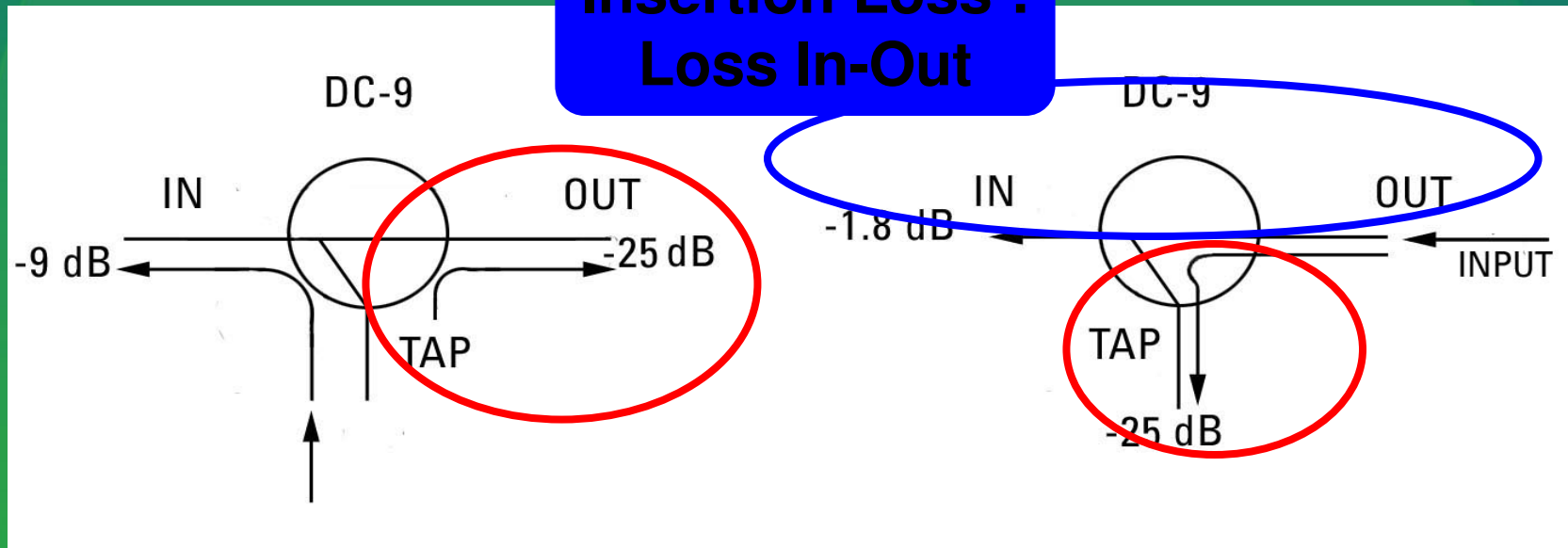

**Isolation Loss :
Loss Tap-Out**

Passive Devices

Directional Tap Schematic

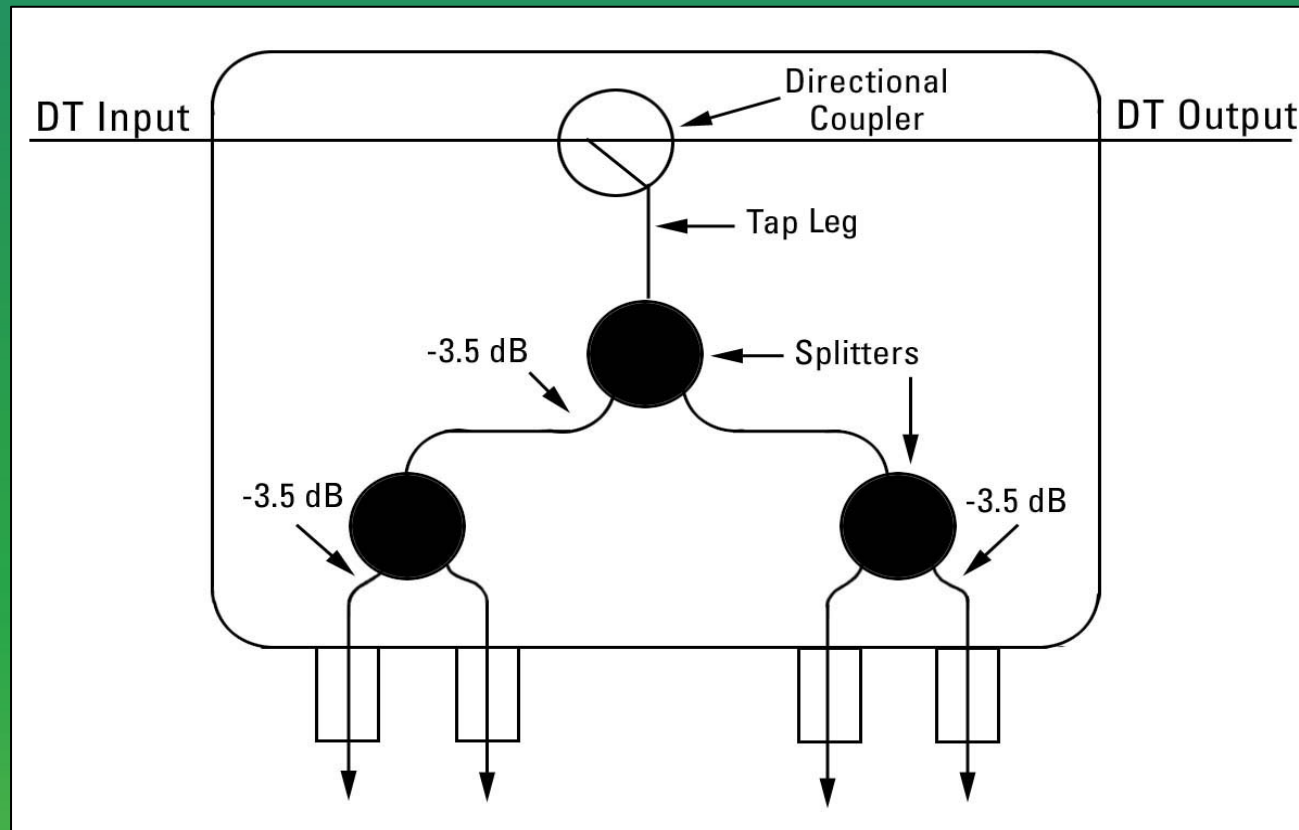

Passive Devices

DT – Insertion Loss

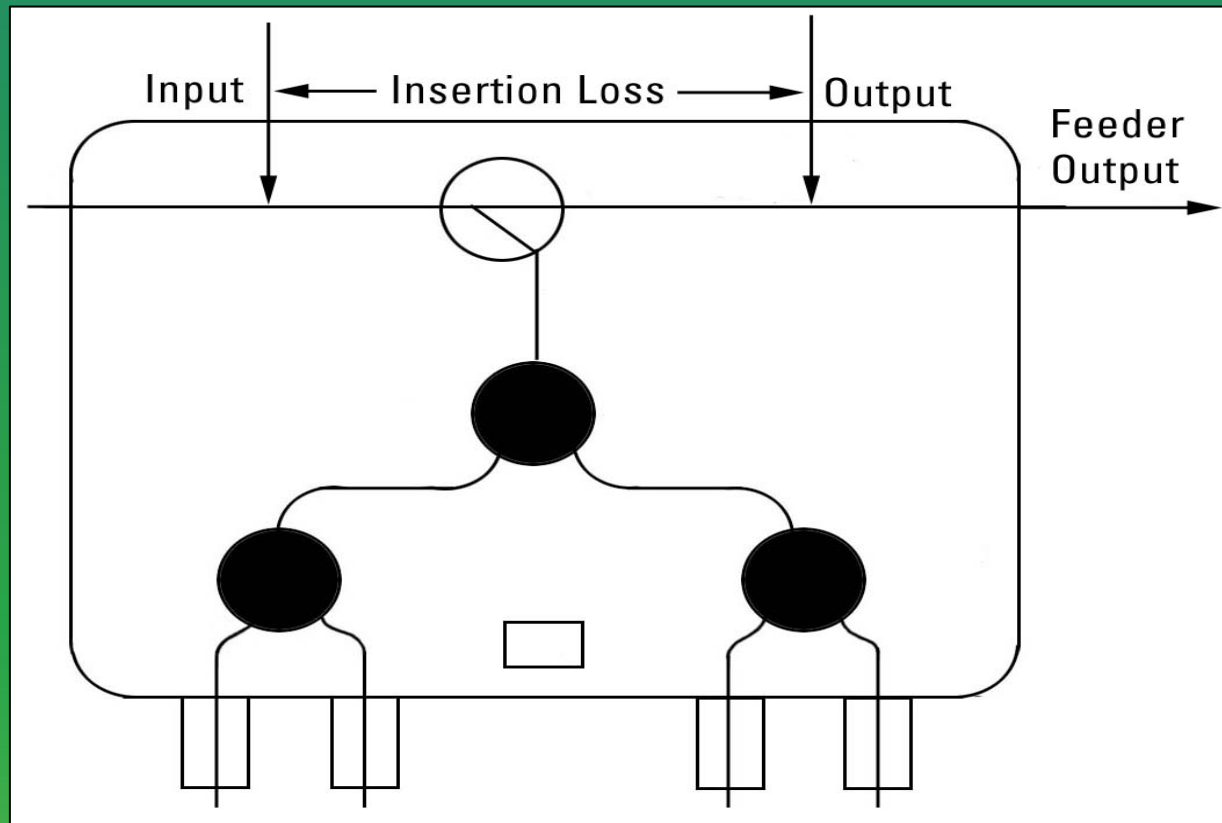

Passive Devices

DT – Isolation Loss

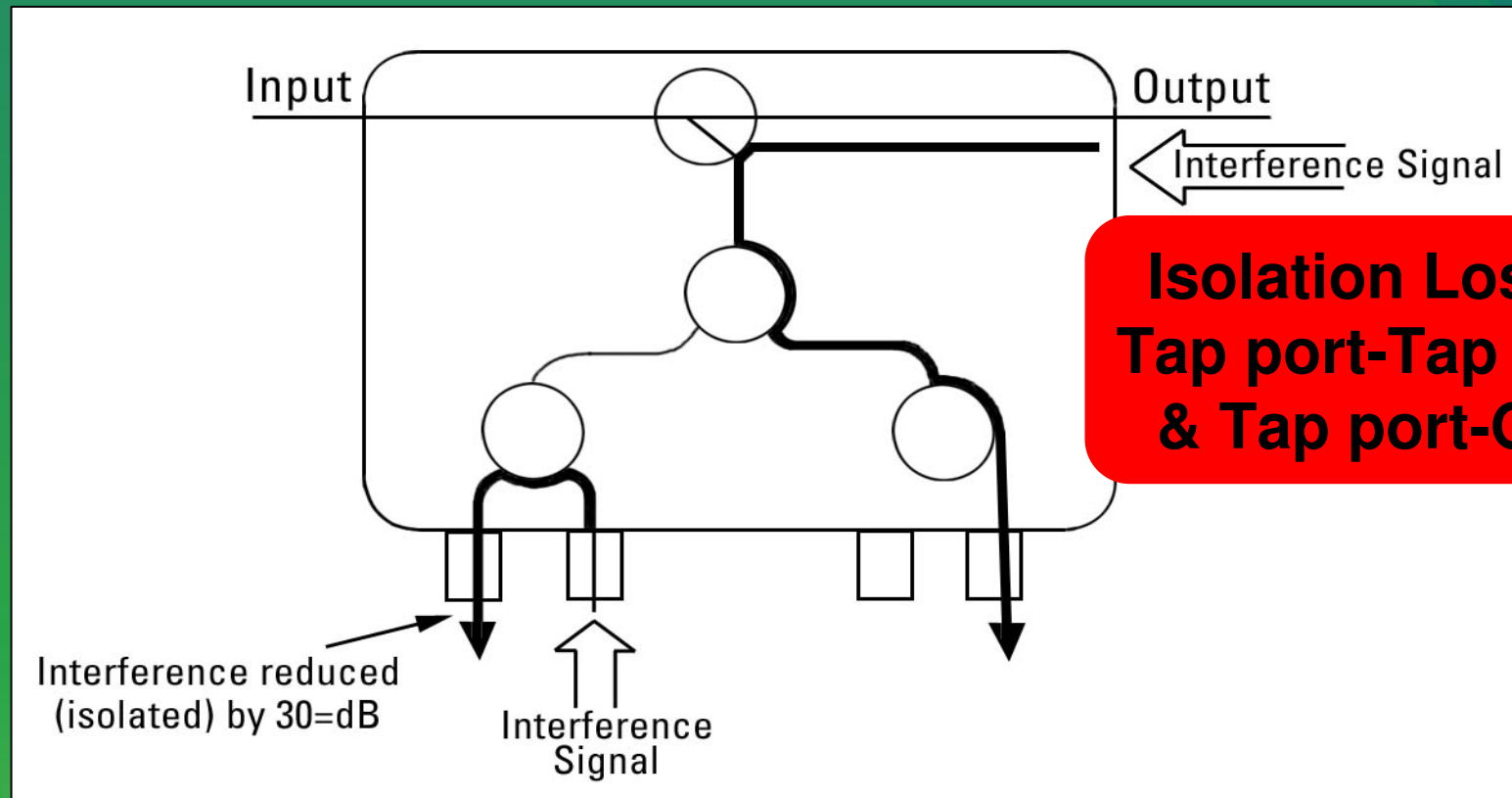

Passive Devices

DT – Tap Loss

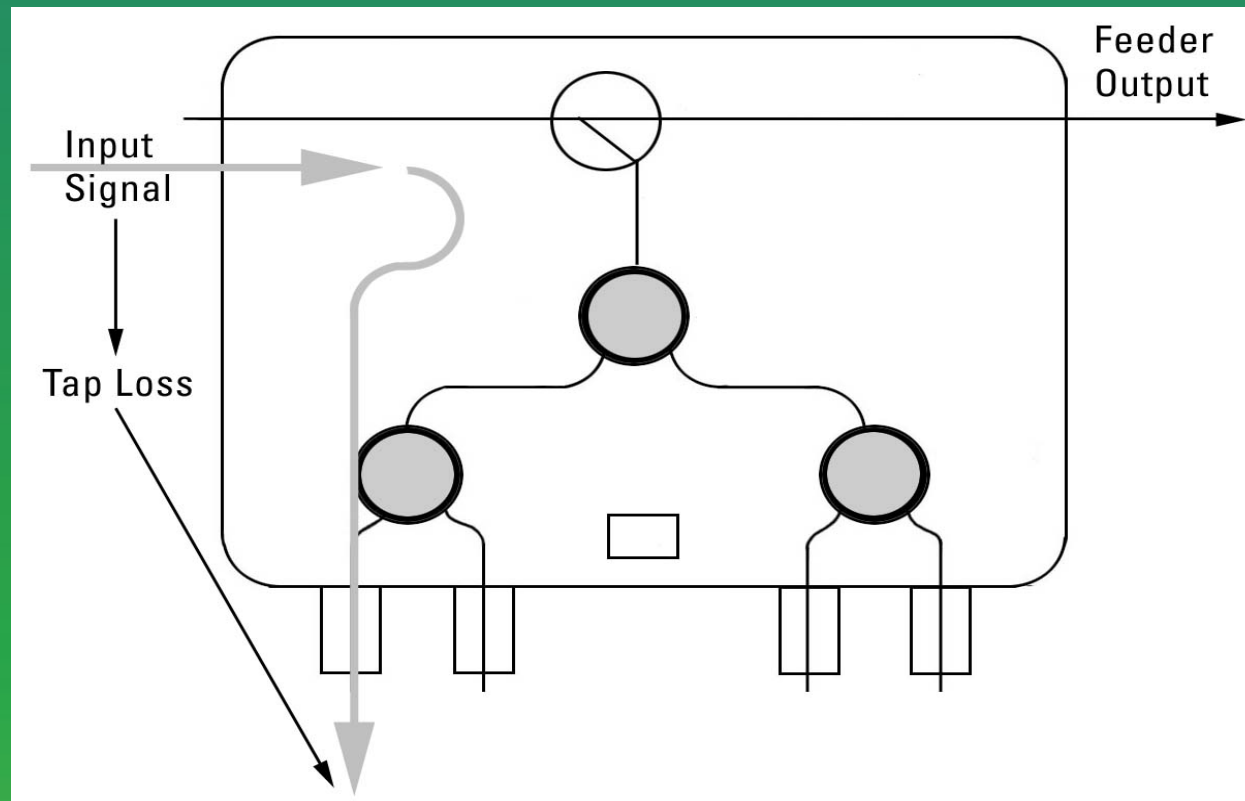

DT Plant Design

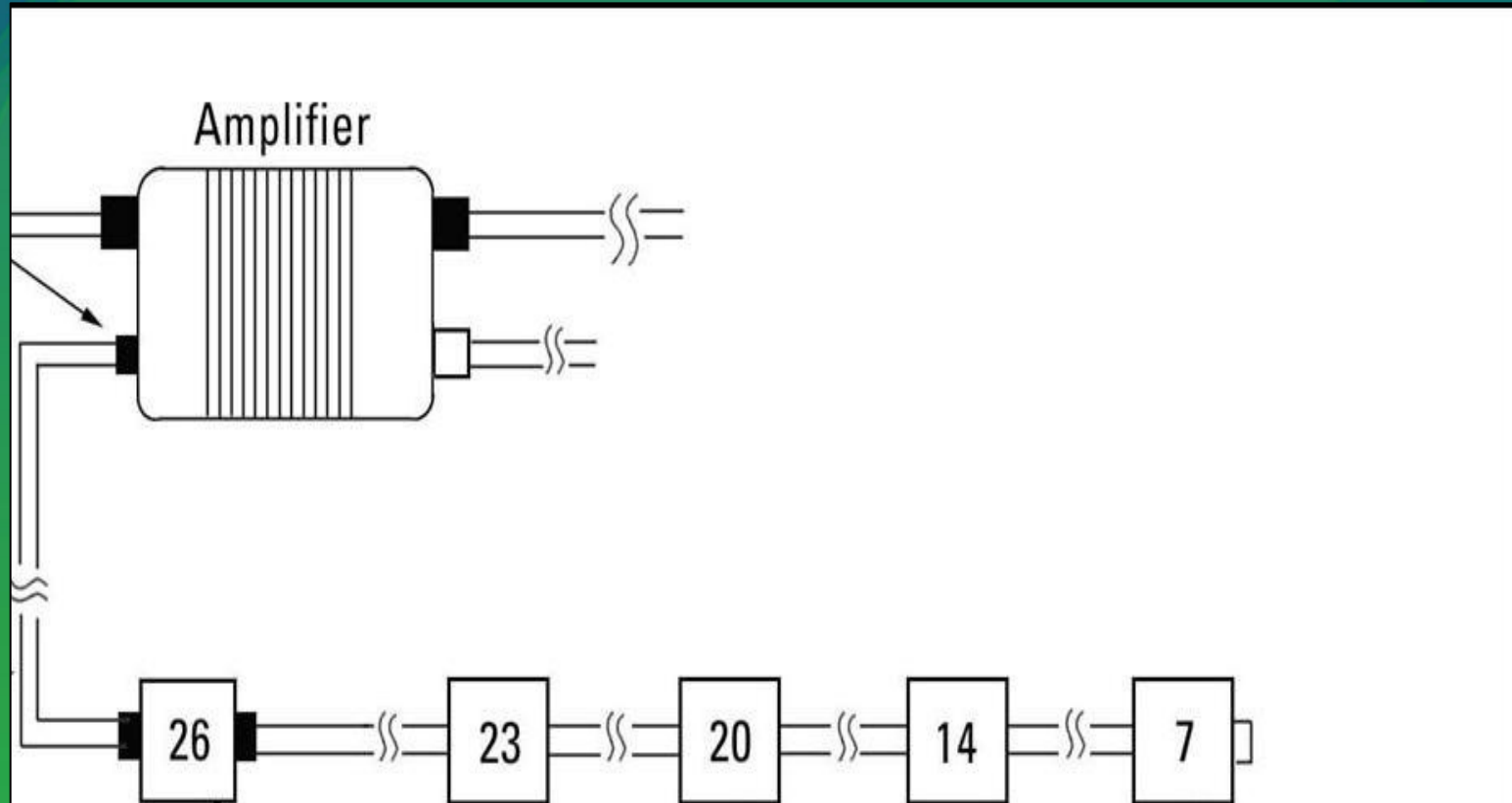



Society of Cable
Telecommunications
Engineers



The Aerial Drop

Connecting the House to the Plant



Society of Cable
Telecommunications
Engineers



Designing the Drop

- Drop Components
 - The Tap
 - The Drop
 - The Demarc
- Where to Locate the Drop

The Tap

- The directional tap splits off a portion of the signal to send to each customer's drop.
- Taps typically have 2, 4, or 8 output ports.

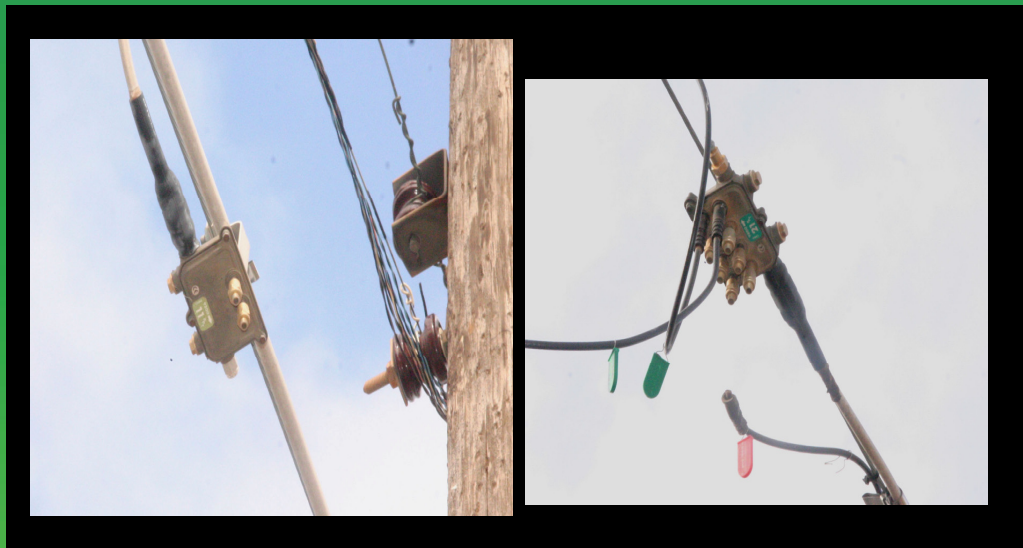

Hardware at the Tap



Directional Tap



**ID
Tags**

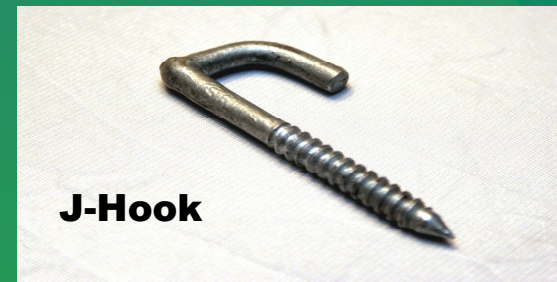

J-Hook

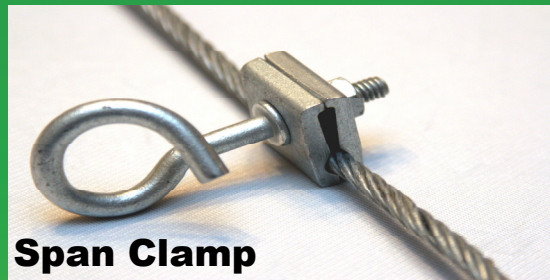

Span Clamp



Locking Terminators



Hardware for the Drop



RG6 Fitting



RG59 Fitting



Grommet



Silicon Grease



Zip Tie

Hardware for the Demarc



Grounding Splitters

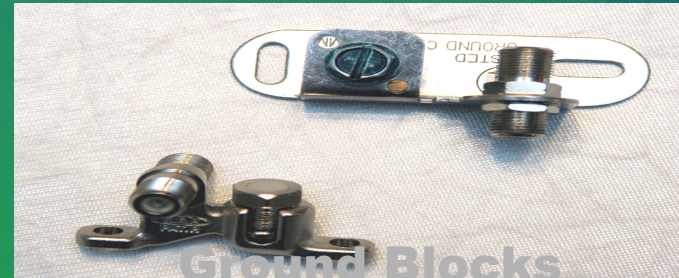

Ground Blocks

Grounding Hardware

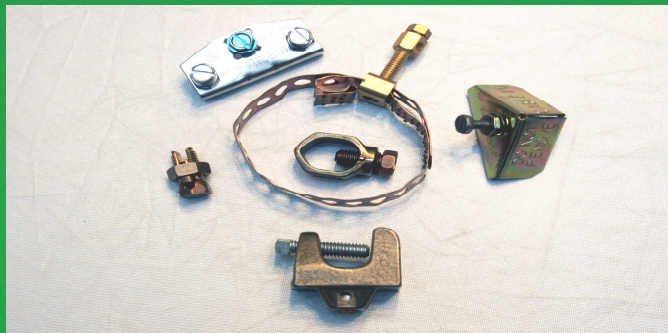

P-Hook





Society of Cable
Telecommunications
Engineers

Design Factors to Consider



- Trespass
- Clearance
- Other Utilities
- Plants/Trees
- Storage Buildings
- Outlet Location
- Grounding
- Swimming Pools
- Appearance



Clearance

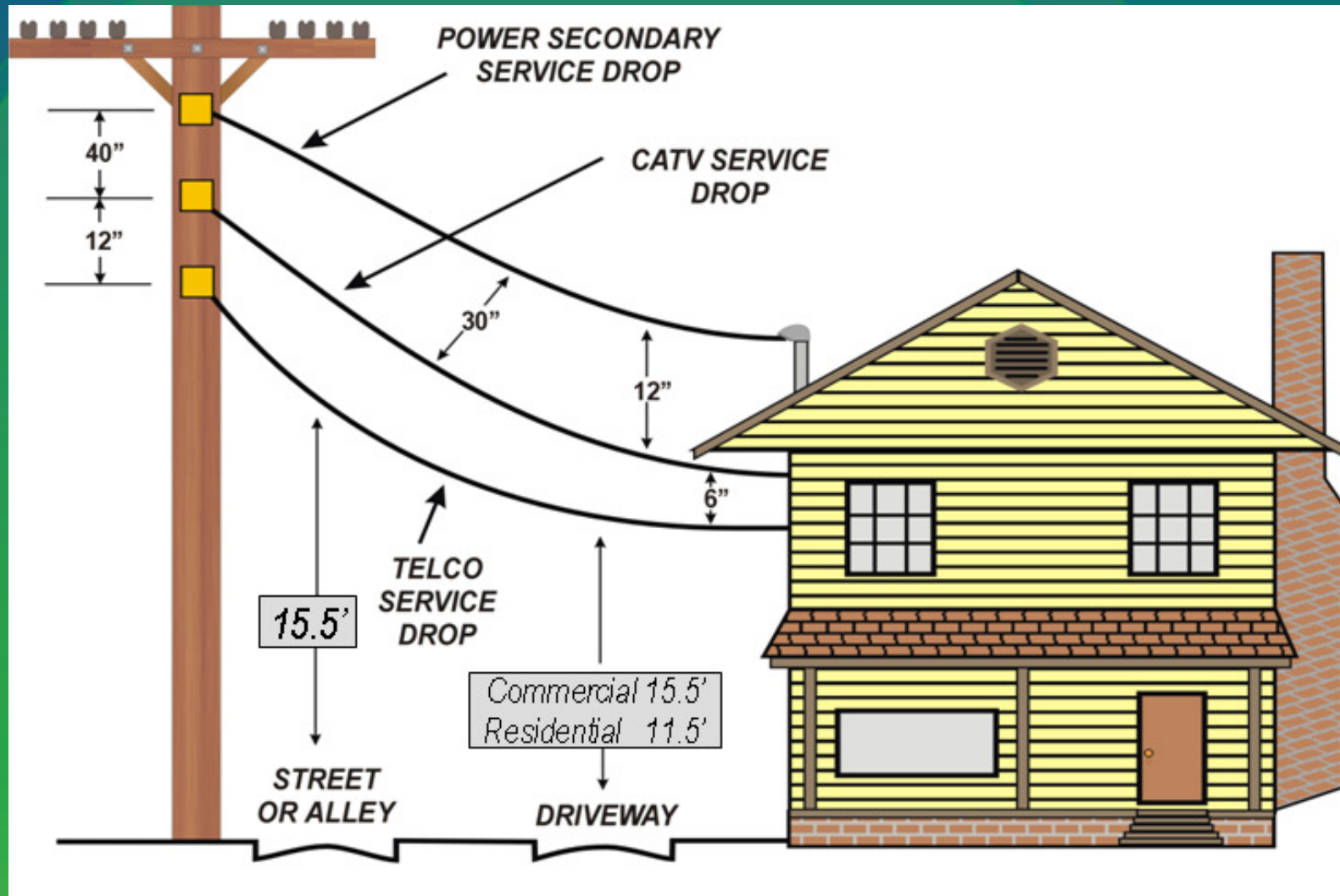

Spacing at the Tap

- **Climbing Space**

Maintain 30" climbing space for all utility technicians.

- **Distance from Pole**

Span clamps must be at least 24" from pole center.

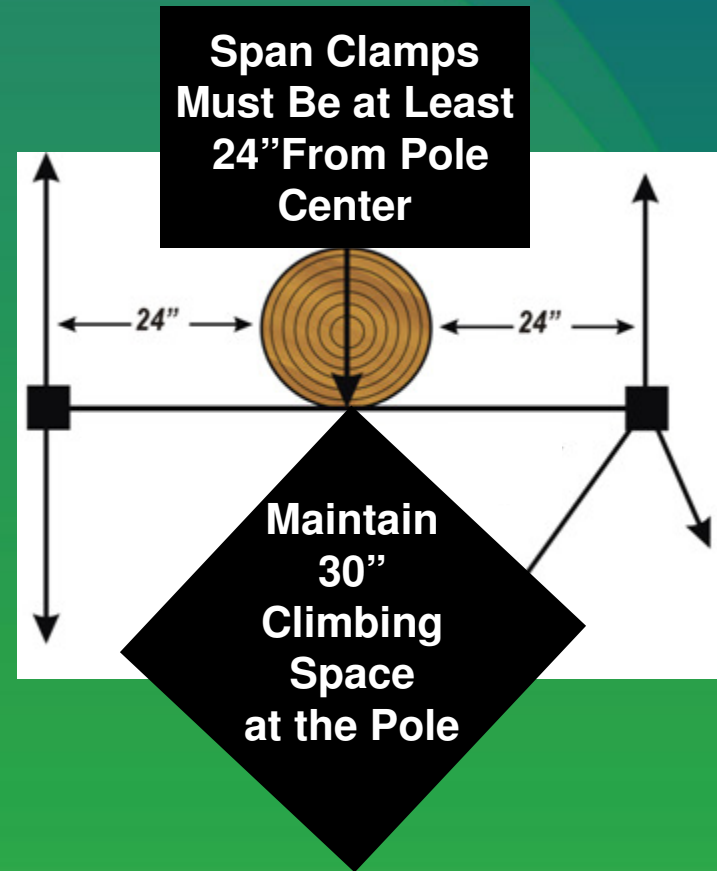

Mid-Span

- Uses:
- to avoid obstructions
- to maintain proper clearances
- to avoid crossing other utility lines
- to avoid property trespass

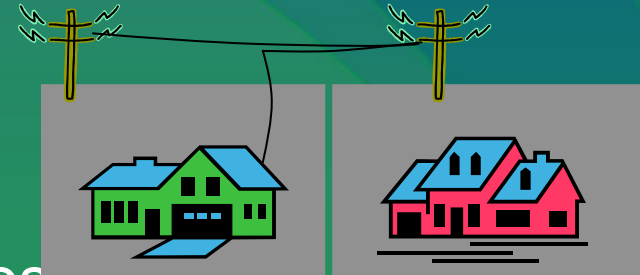

- Always use two span clamps when running a mid-span drop.
- The mid-span requires four 3-3-5 wraps:
 - One at the tap
 - Two at “mid” span
 - One at the house

**Start your mid-span at the tap.
Never start at the house!**

Trespass

**Always use
a mid-span
drop to
avoid
crossing
property
lines**

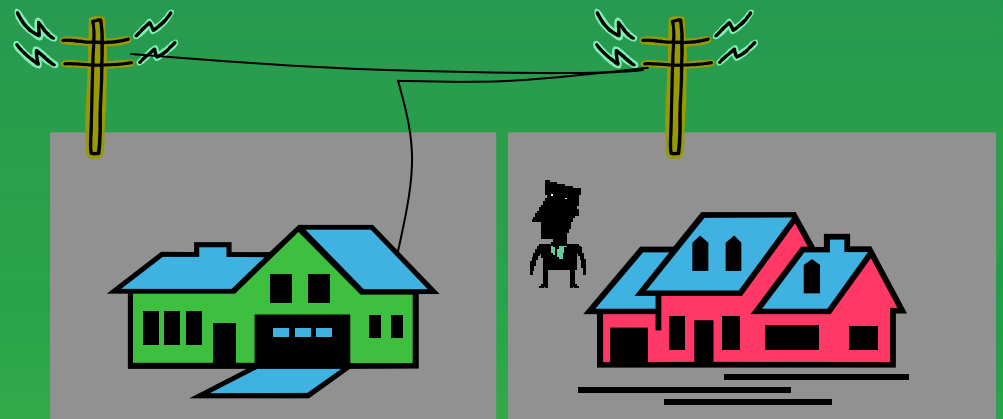
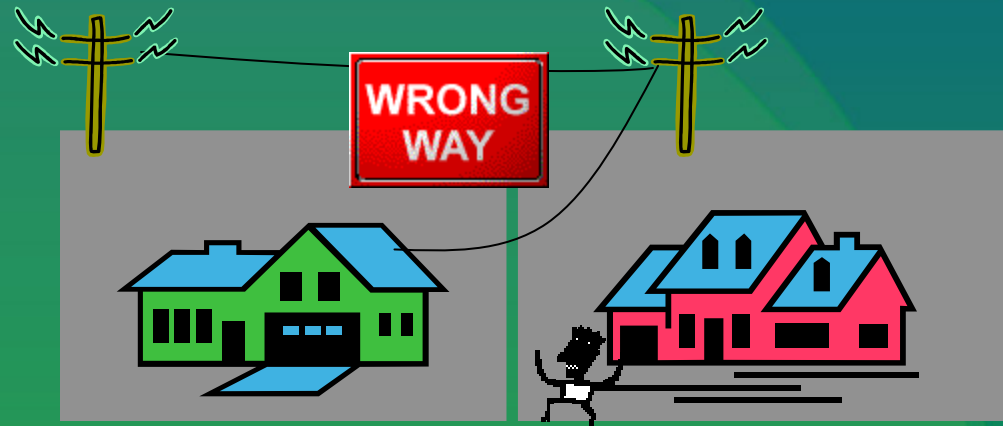

J-Hook

A J-Hook can be used to gain extra height or to clear an obstruction.



- Hammer the J-Hook into the utility pole until 1 1/2" is exposed – there should be no thread showing.
- Be careful not to obstruct the 30" climbing space.
- Always attach loose cable to the utility pole using clips or staples.
- Never use a P-Hook in place of a J-Hook



Society of Cable
Telecommunications
Engineers



Installing the Drop

Coax Messenger Cable

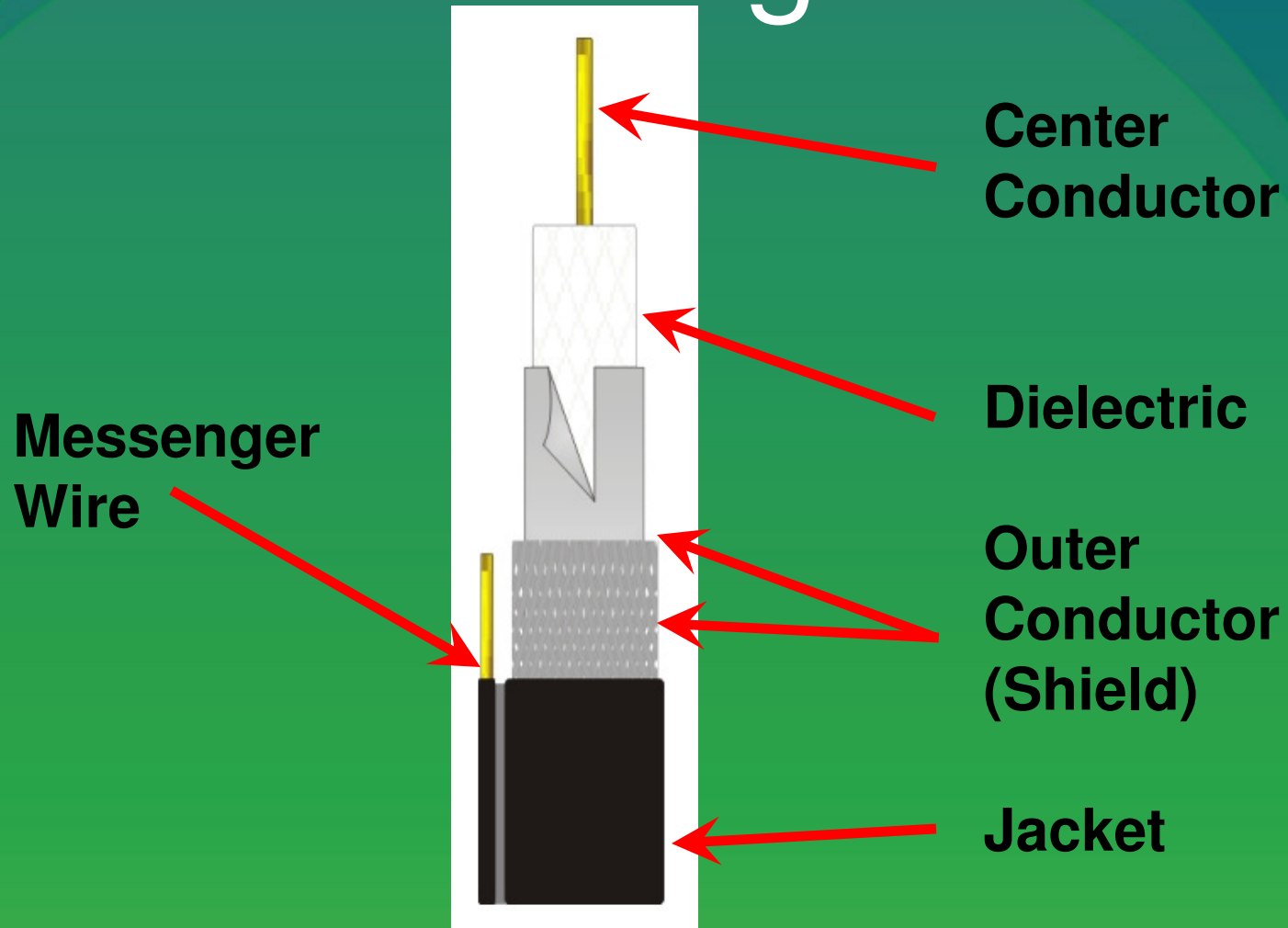



Society of Cable
Telecommunications
Engineers



Installing F-Connectors

Make sure dielectric is flush with base of fitting before compressing.

Make sure there is no dielectric or braid clinging to the center conductor.

Do not scrape center conductor with any metal objects.

Leave stinger $1/16''$ to $1/8''$ beyond the end of the fitting – do not cut flush.

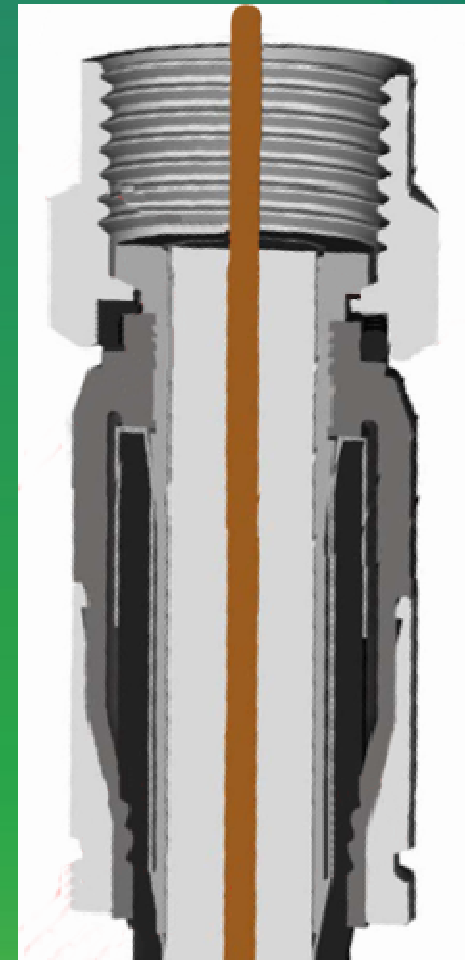

Weatherproofing

- Use a grommet and silicone grease on every outdoor connection.
- Make drip loops and service loops.

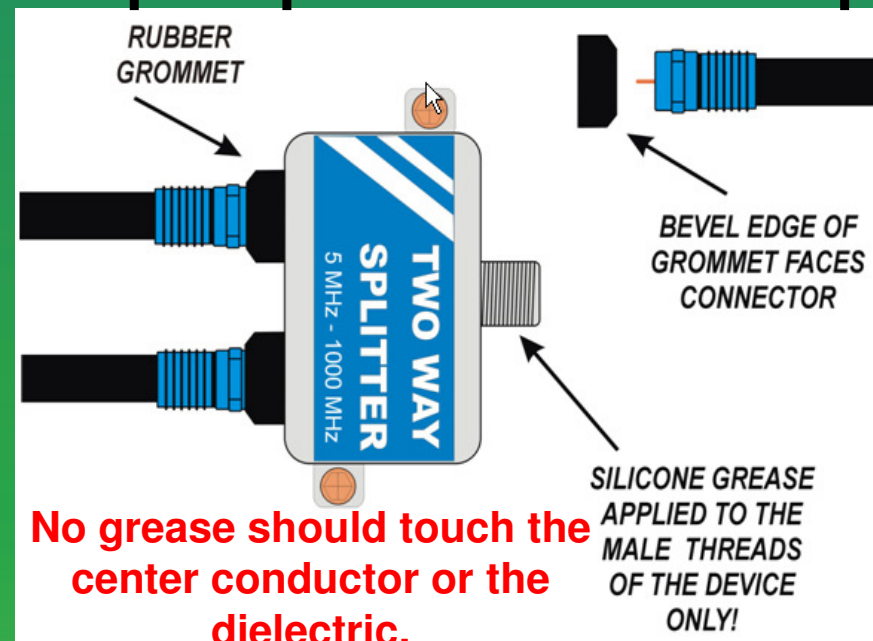



Steps for Mid-Span Attachment

1. Cut the messenger wire – be careful not to cut into the jacket.
2. Peel back messenger wire in both directions.
3. Starting with tap end, install drop hanger and place on the span clamp.
4. Roll up a service loop with a 4-6" diameter.
5. Place zip ties on the service loop at 10, 2, and 6 o'clock.
6. Install another drop hanger on the house end.

Connect to Tap



Connect Mid-Span



Connect to House



Society of Cable
Telecommunications
Engineers



Avoiding “the Bite”



Cable TV Installer Killed After Falling 21’ From a Ladder

The victim had not reset the ladder and was not wearing fall protection as required by the company. The co-worker started to tell him to put on the safety belt when the victim cut the cable leading away from the junction box. As the tension from the cable was released, the main cable and strand swung backwards, whipping the ladder attached to it. Although the ladder did not come off the strand, the movement threw the victim off the ladder to the asphalt road. The co-worker ran to the house and called the police who responded with the first aid squad. The victim was transported to the local hospital where he was pronounced dead.

Proper Slack

Two considerations for proper drop slack:

- Six inches of slack for every 50 feet of drop – even with a mid-span
- Try to keep drop parallel with other utility drops

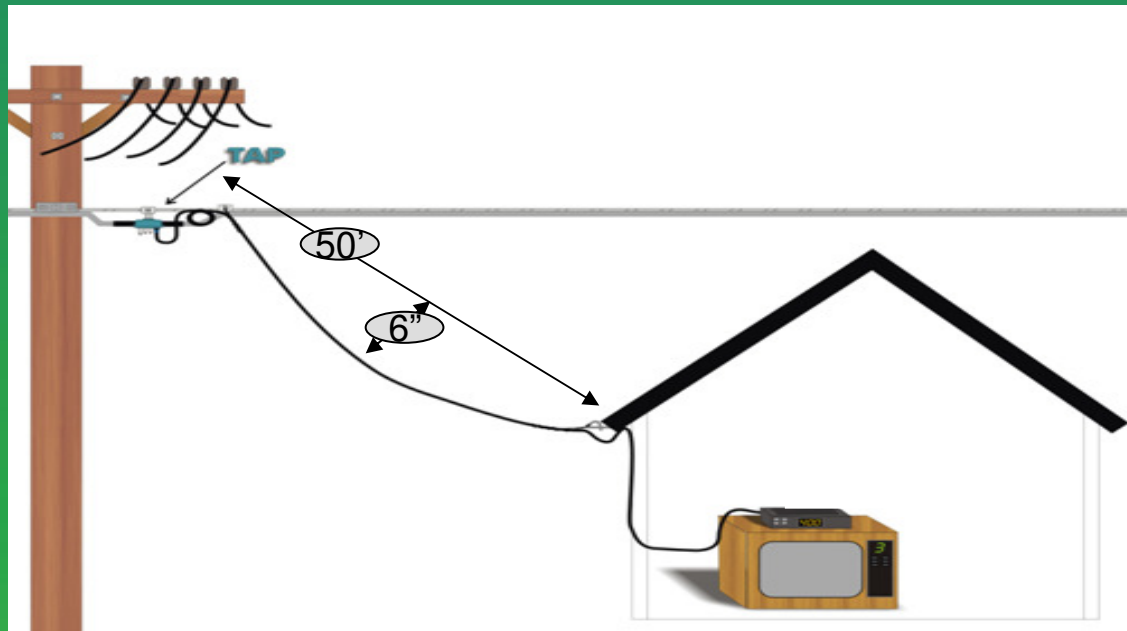

Attachment to the House

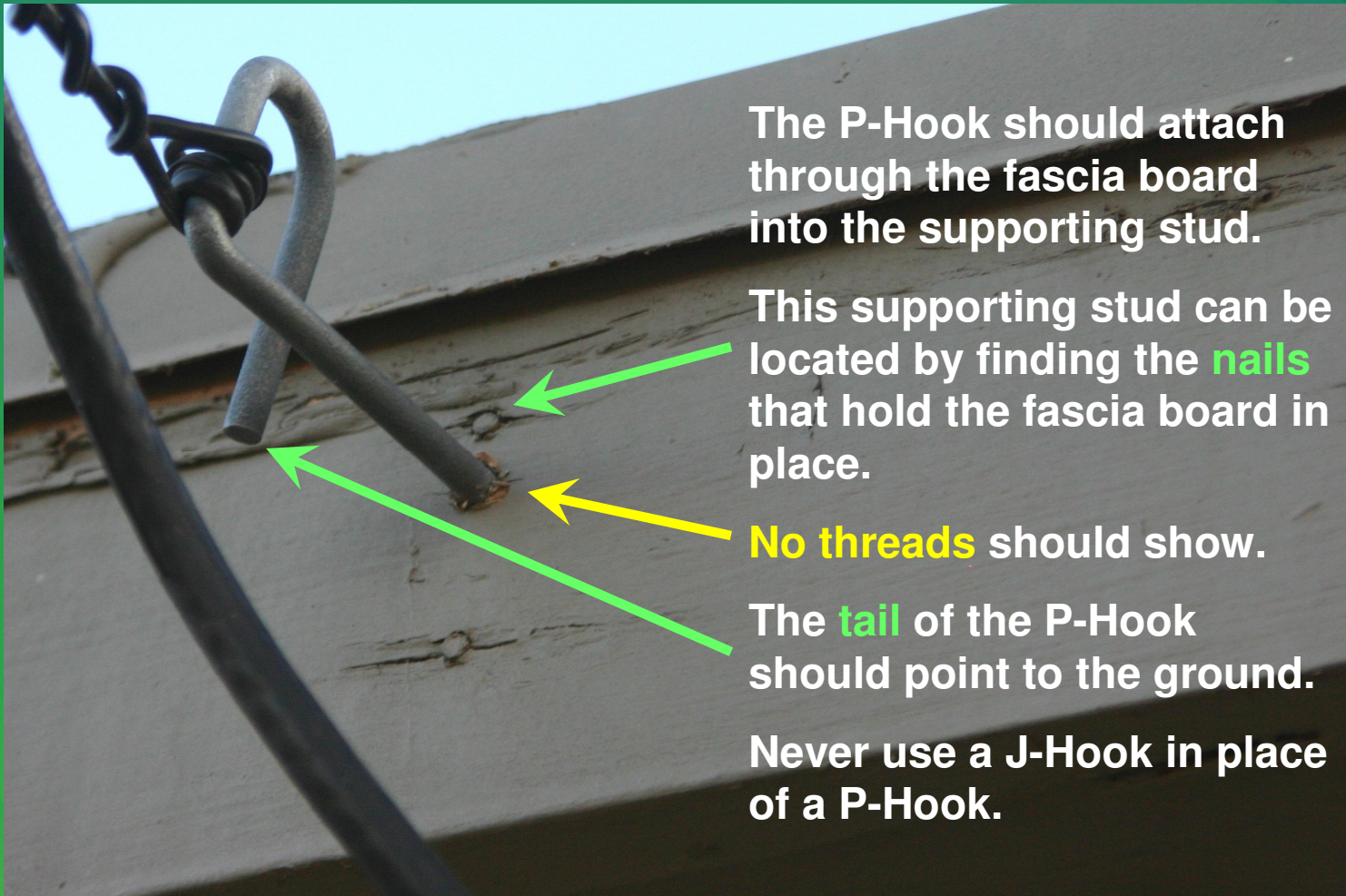

The P-Hook should attach through the fascia board into the supporting stud.

This supporting stud can be located by finding the **nails** that hold the fascia board in place.

No threads should show.

The **tail** of the P-Hook should point to the ground.

Never use a J-Hook in place of a P-Hook.



Society of Cable
Telecommunications
Engineers



Evaluating an Existing Drop

Inspecting the Tap

- Loose, corroded, or improperly installed F-connectors.
- Customer drops with incorrect or missing tags.
- Damaged drop cable, messenger, or attachments.
- Un-terminated tap ports.

Loose
Lashing
Wire



Squirrel
Chew

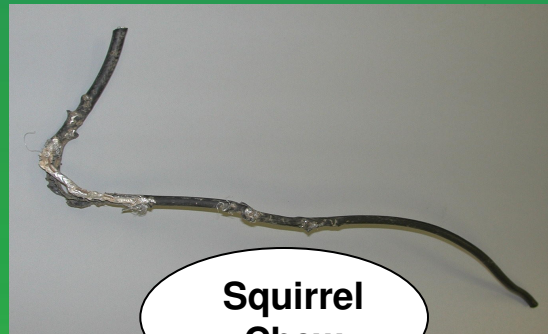

Broken
Tap Port

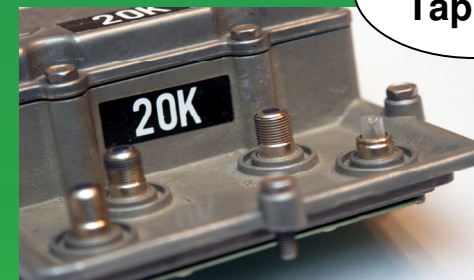



Society of Cable
Telecommunications
Engineers



Checking Signal Level

In order to save troubleshooting time and to prevent unnecessary trips up the ladder, always check signal level in three places on every job:

- The Tap
- The Demarc
- The Outlet

Low, middle, and high analog

Checking for Ingress

- In order to check a drop for ingress:
 1. Disconnect both ends of the drop.
 2. Place a 75-ohm terminator (locking or non-locking will work) on one end of the drop.
 3. Place your signal level meter on the other end of the drop.
 4. Power the signal level meter on, go into the Navigator menu, and select the ingress detection icon. (This process is covered more completely in the *Signal Level Control* lesson.)



Upgrading the Demarc



Replace all painted or corroded splitters, ground blocks, fittings, and grounding hardware.

Replace any aftermarket splitters with company-issued splitters that accommodate 5-1000mHz.

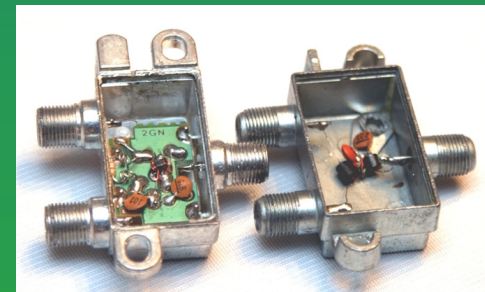

Make sure that all grounding hardware is shiny – replace any old or corroded hardware.



Society of Cable
Telecommunications
Engineers



Grounding



- Grounding - The National Electric Code

The NEC provides a set of standards for the electrical and communications wiring in homes.

The basic NEC requirement is for a common ground.

- **We accomplish this by bonding together our service at the power ground location.**

Purpose of a Ground

- Protects people from electric shock.
- Protects equipment from damage caused by a surge of electricity.

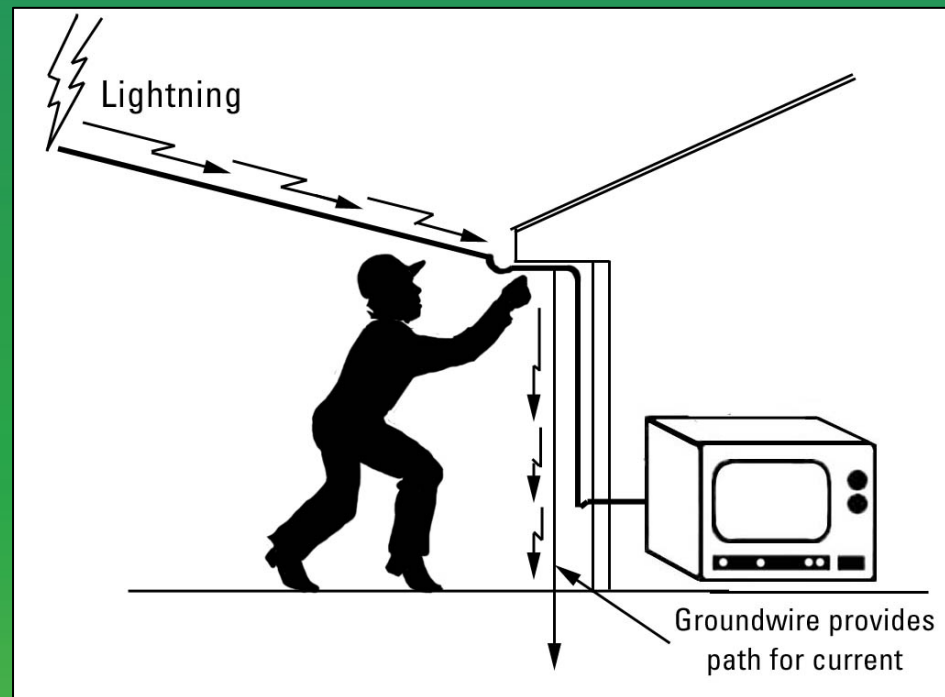

Bonding and Grounding

Bonding – connecting all electrical sources together.

Grounding – connecting all sources to the earth.

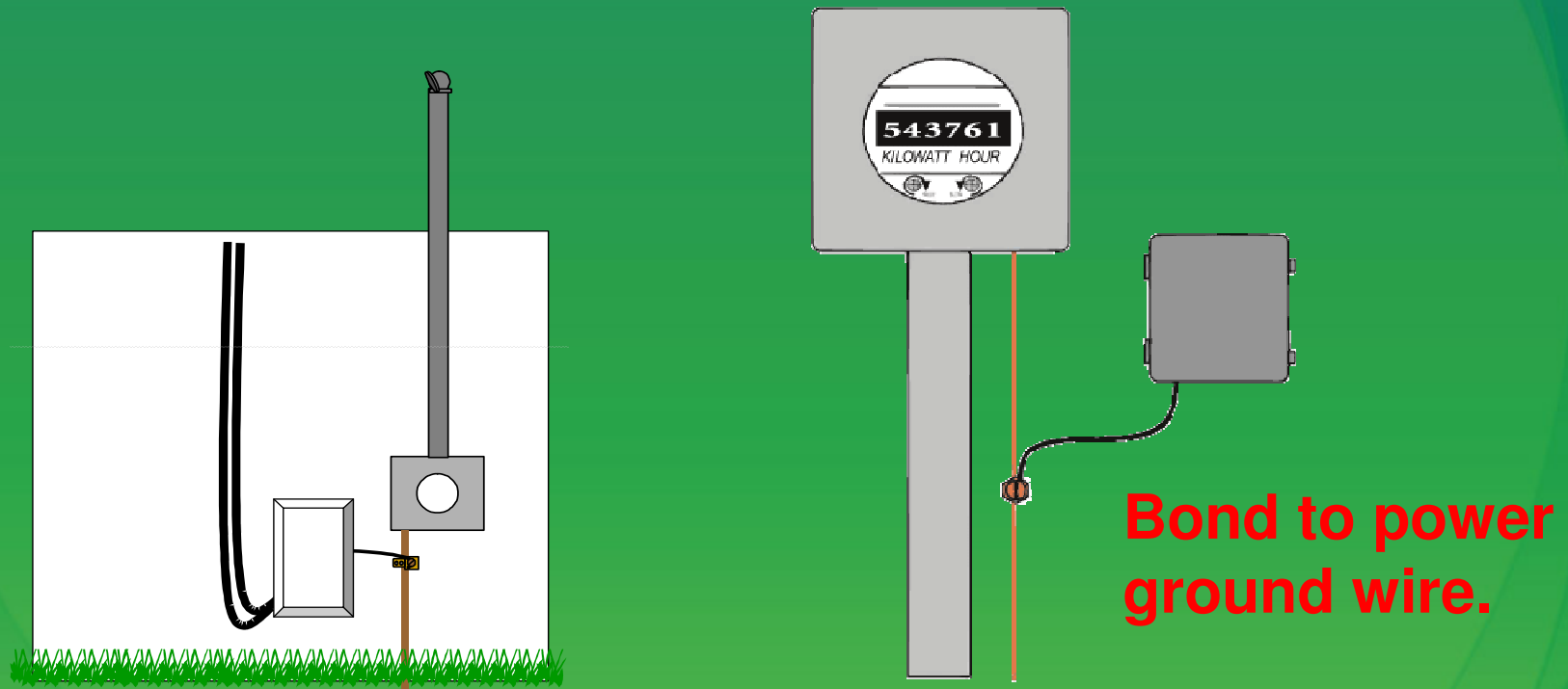



Grounding

Use #12 wire – do not use messenger wire!

Ground wire should not exceed 10' or the distance to the nearest outlet – whichever is shorter.

The key to a good ground is co-bonding with the existing power ground.

Replace any corroded connections.

Splitters/ground blocks must be mounted horizontally (left and right).

Hazards of Improper Grounding

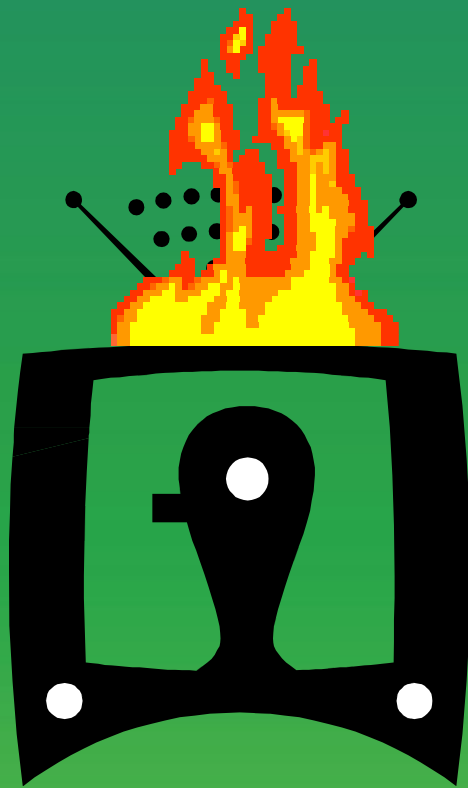



Society of Cable
Telecommunications
Engineers



Signal Levels



Signal Levels

- Identify the unit measuring signal strength.
- List the factors that effect signal strength.
- Calculate cable loss.

The Decibel-Millivolt

- dBmV is the standard unit to measure signal strength.
- It was derived from Alexander Graham Bell's experiments of sound intensity.
- **0dBmV = 1 mV across 75 Ω**

Signal Level	Voltage Equivalent
-12 dBmV	.25 mV
-6 dBmV	.5 mV
0 dBmV	1 mV
+6 dBmV	2 mV
+12 dBmV	4 mV

Reference





Signal Strength

Factors That affect RF Transmission

Attenuation – loss of signal

- Cable Loss
- Passive Loss
- Cable Loss
 - Size of Cable
 - Frequency
 - Length
 - Type of Cable
 - Temperature

Signal Gain - amplification

All values are expressed in dB

Cable Loss

Size of Cable

- Drop cables are identified by RG (radio grade)
- Plant distribution cables are identified by their diameter in decimal inches.

Frequency

- Commonly measured in MHz
- “Skin Effect”

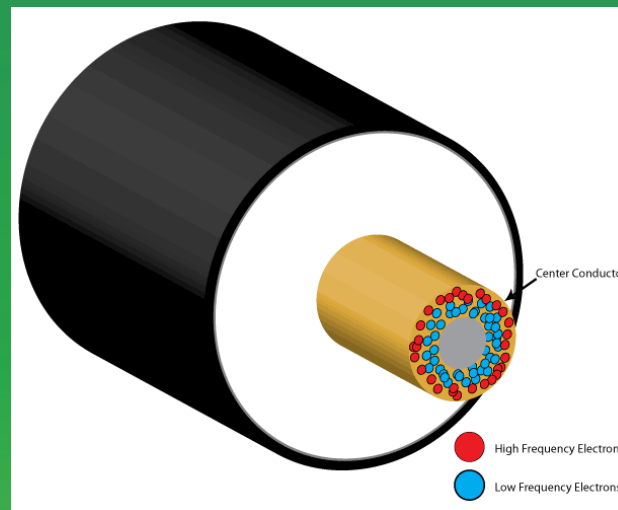



Cable Loss (cont.)

Length

- All cable loss charts are shown in dB / 100 ft.

Type of Cable

- This corresponds to the manufacturer and the application.

Temperature

- The higher the temperature the more cable attenuation.
- For all practical purpose, we can ignore this effect in the drop system.



Cable Loss Calculations

Cable Size	5 MHz	32 MHz	50 MHz	300 MHz	400 MHz	550 MHz	750 MHz	865 MHz
RG-11	0.38	0.74	0.92	2.25	2.60	3.04	3.65	3.98
RG-6	0.58	1.19	1.53	3.55	4.15	4.90	5.65	6.10
RG-59	0.86	1.51	1.95	4.45	5.10	5.95	6.97	7.52

Values in dB / 100 ft

The formula for calculating cable loss:

$$\text{footage} \times \frac{\text{dB of Loss}}{100 \text{ ft}}$$

Example:

100 ft of RG-6 has 5.65 dB of attenuation at 750 MHz
The same cable will attenuate 0.58 dB at 5 MHz.

What is the loss of 250 ft of RG-6 at 865 MHz?

$$\frac{250 \text{ ft}}{1} \times \frac{6.10 \text{ dB}}{100 \text{ ft}} = -15.25 \text{ dB}$$

Signifies loss



Society of Cable
Telecommunications
Engineers



Signal Transmission



Signal Transmission

- Define tilt.
- Identify coaxial cable impedance.
- List causes of impedance mismatch.

Tilt

- **Tilt is defined as the difference in signal levels at different cable channels.**
Typically used to describe the difference between high and low carriers.
- **Used to offset the effect that cable loss has on signal levels.**

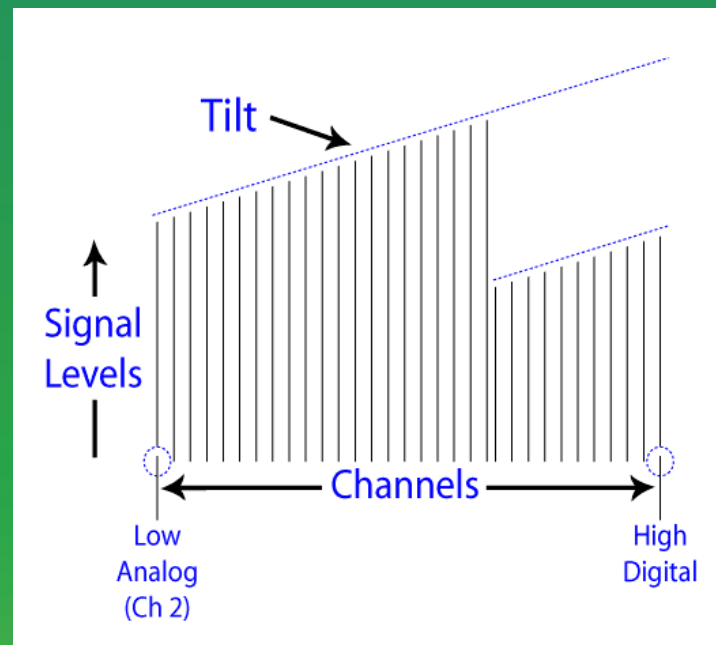

Signal Distribution

- As signals travel down the distribution lines, the higher channels will eventually have lower signal levels than the lower channels.

Think back to our discussion on “skin effect”.

- This is why you will see different tap values in the CATV plant.

The closer a tap is to an amplifier, the higher the tap value.

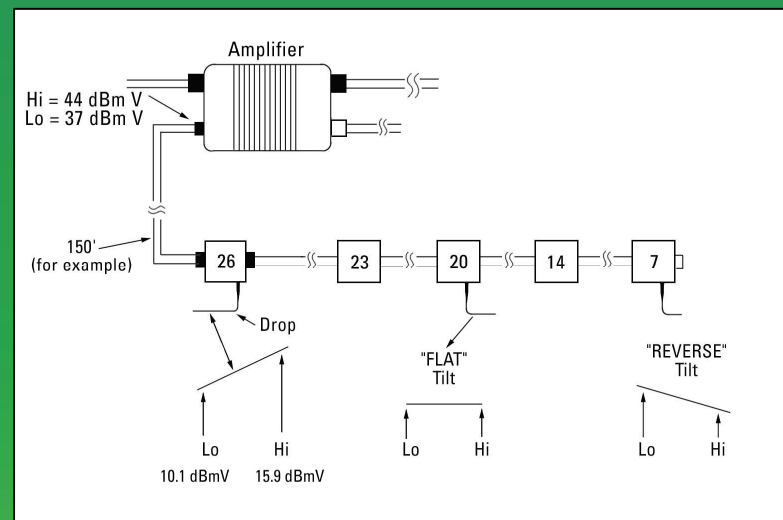

Cable Impedance

Impedance is the apparent RF resistance between the center conductor and the outer conductor.

Changing the characteristic impedance can affect the cables' transmission quality.

The characteristic impedance is 75 Ω

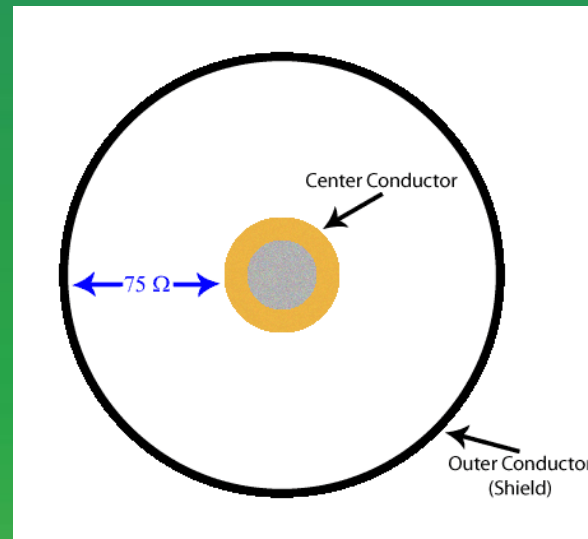

Impedance Factors

3 Factors that determine cable impedance

- Ratio of the center conductor to outer conductor
- Distance from the center conductor to outer conductor
- Type of dielectric material used

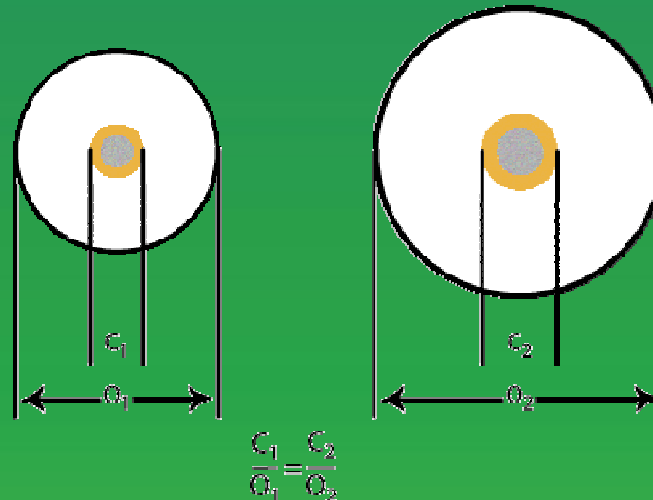

C - Center Conductor Diameter
 D - Outer Conductor Diameter



Society of Cable
Telecommunications
Engineers



Group Activity

List some things that can cause the cable impedance to change.

List some things you can do to prevent impedance mismatch. (a loss of signal energy do to a change in the cables' impedance)



Society of Cable
Telecommunications
Engineers



Frequency



Frequency

- Identify commonly used term for frequency.
- Define modulation.
- Identify forward and return channel allocations.

Radio Frequency (RF)

**Frequency – the number of cycles over time
(cycles per second)**

- **In CATV you will commonly hear Megahertz (MHz).
(millions of cycles per second)**

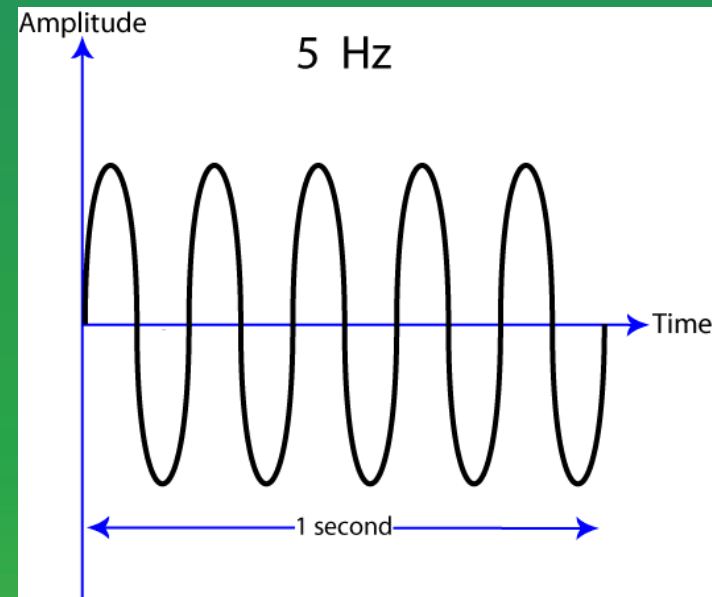
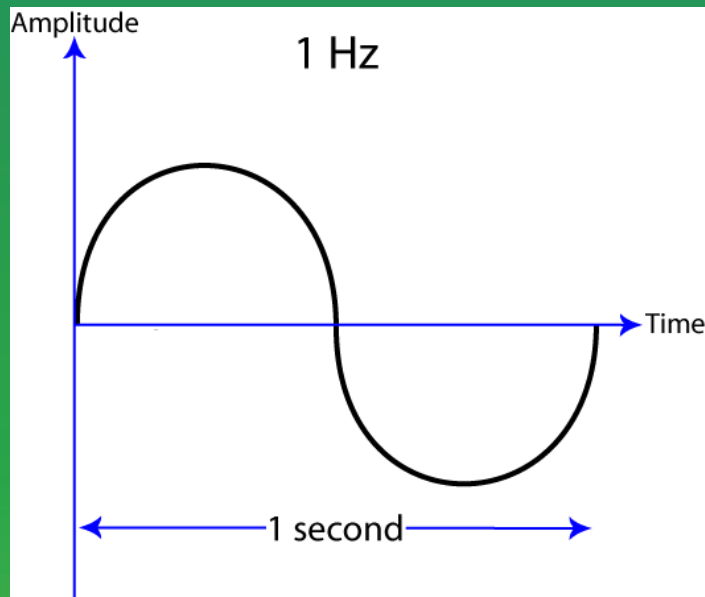

TV Channels

Modulation – placing intelligent information onto a radio frequency (RF) carrier wave

- The information is allocated a **6 MHz** space called a **channel**.

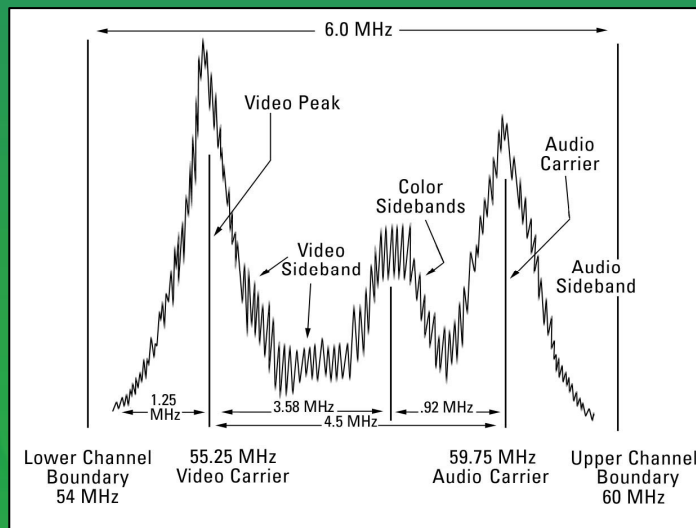

Channel Allocation

Typical System Channel Allocation Off-Air Allocation

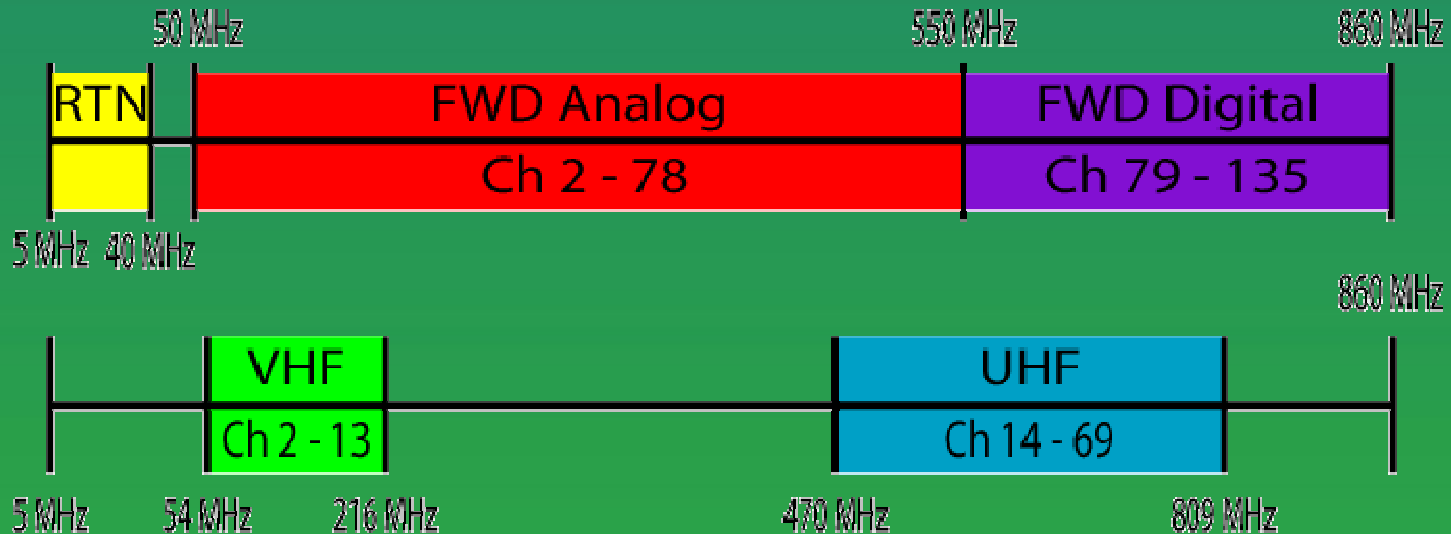



Society of Cable
Telecommunications
Engineers



Signal Level Meter



Signal Level Meter

- State the purpose of a Signal Level Meter.
- Maintain your SLM.
- Measure signal levels on the cable plant.



Society of Cable
Telecommunications
Engineers



Signal Level Meter (SLM)

A SLM is basically a frequency tuned voltmeter.

The main uses for a Tech are:

- Measure cable signals
- Locate non-CATV signals on the cable line.



Preventative Maintenance

The **“key”** to accurate measurements and long time usage of any meter is proper care and maintenance.

- 🔑 Change jumpers regularly
- 🔑 Replace all F-81's frequently
- 🔑 Calibrate noise floor once a month or if dropped
- 🔑 Protect from the elements

Preventative Maintenance

- Failure to maintain these items may result in improper readings
- Keep them in check

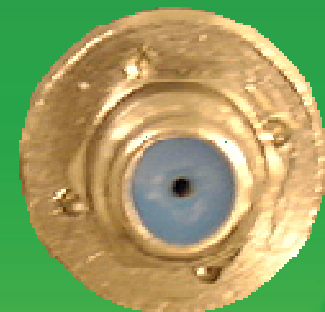

Preventative Maintenance

- 🔑 **Protect meter from extreme moisture.**
- 🔑 **Do not expose LCD to direct sunlight for prolonged periods.**
- 🔑 **Keep LCD from freezing, store inside when not in use.**





Society of Cable
Telecommunications
Engineers



Signal Leakage



Signal Leakage

- Explain how signal leakage can occur.
- Define egress and ingress.
- State the FCC Rules for signal leakage.
- Identify common sources of signal leakage.

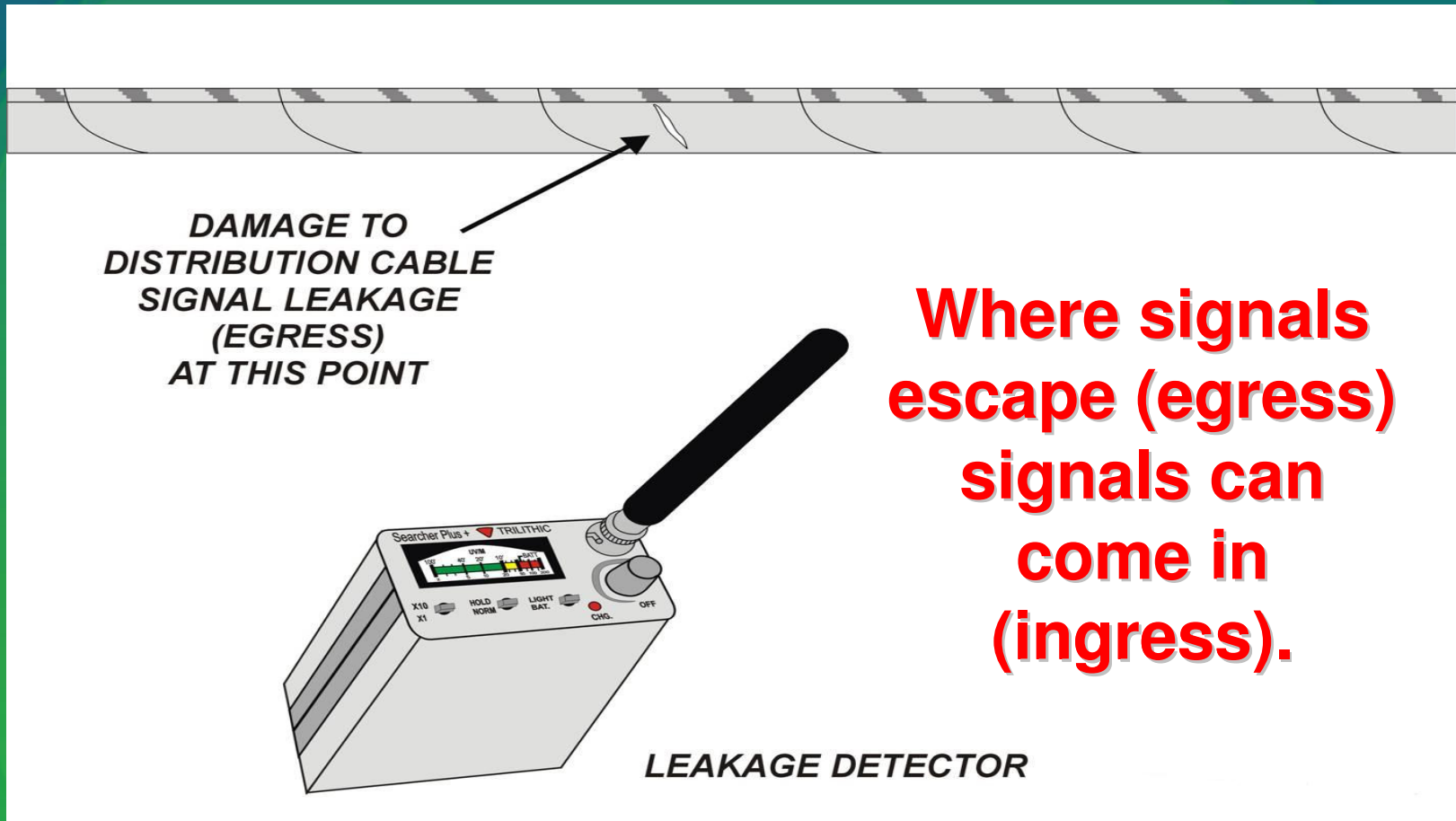



The FCC

The Federal Communications Commission govern the maximum strength of signals that can be leaked from the cable system.

The amount of leakage that is measured and repaired within a CATV system is known as Cumulative Leakage Index (CLI).

If signal leakage is left unchecked the leak can interfere with other operating frequencies, including the aeronautical band.

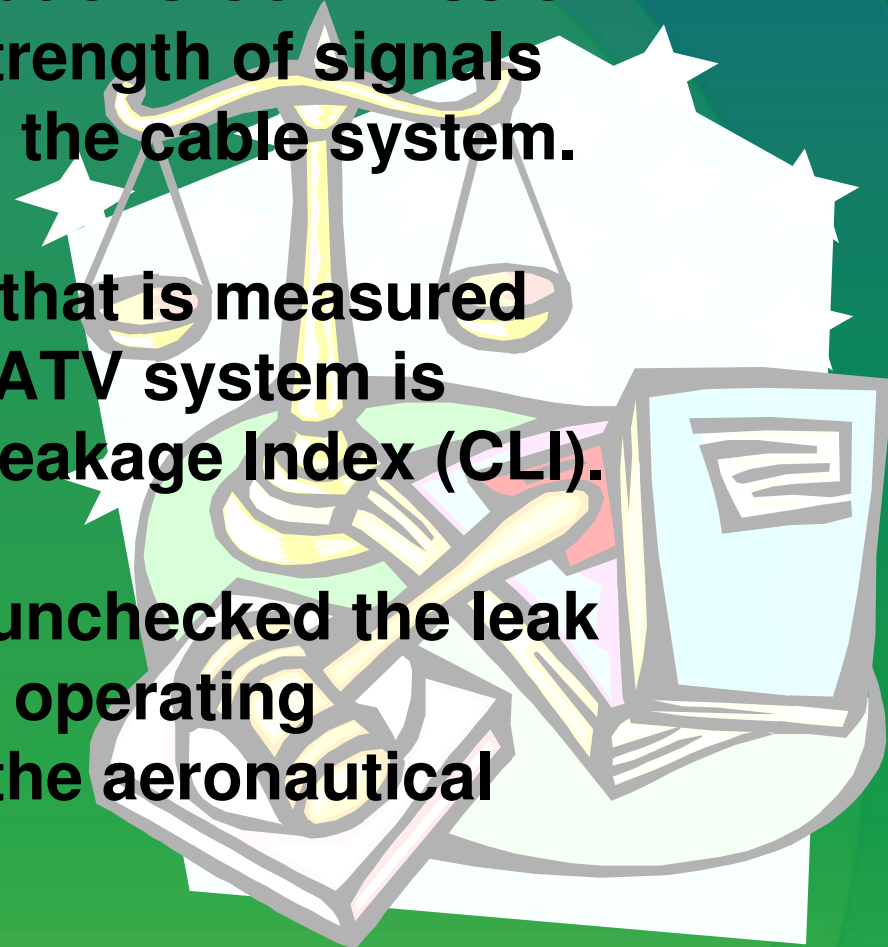



Society of Cable
Telecommunications
Engineers



Common Causes

- Animal chews
- Poor quality cable/construction
- Customer installs
- Un-terminated tap ports
- Poorly installed connectors
- Signal Theft

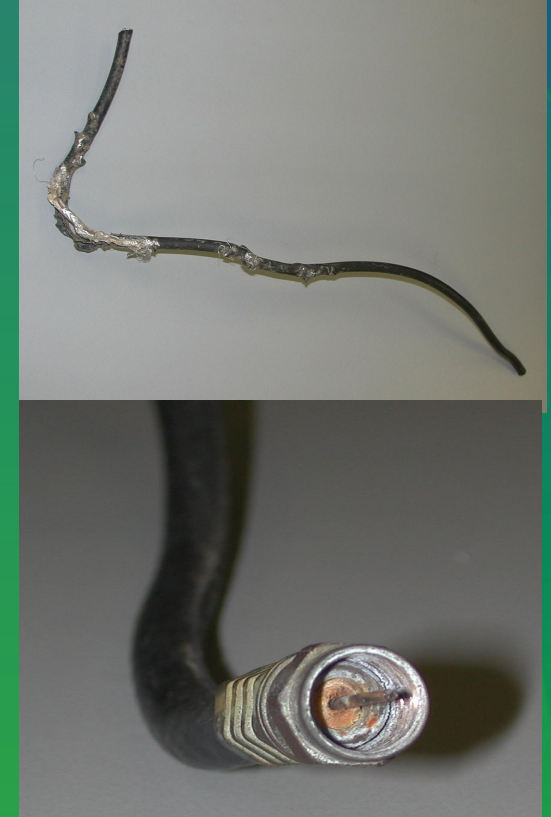

90% of all signal leakage occurs in the cable drop and/or its related fittings.

75% of all service calls are signal leakage related.



Society of Cable
Telecommunications
Engineers



Troubleshooting Video Problems

Divide and Conquer!



Steps for Troubleshooting

1. Analyze
2. Isolate
3. Fix
4. Verify



Know how the system works

- Remember the basics.
- Always know what you expect your signal levels should be before you measure them.



Distinguish the symptoms

1. Interview the customer

- How many TV's?
- Is problem on all TV's?
- How many outlets?
- When did problem start?
- What other symptoms have they noticed?
- Any recent work on house or yard?
- Is data/phone service having problems?

2. Verify symptoms

- Verify picture, color and sound on all channels
- Verify local ingress channels
- Check that all digital services are available



Verify Everything

- Check signal levels at:
 - Tap
 - Demarc
 - Outlet
- Check for quality components
 - Jumpers
 - Fittings
 - 5-1000 MHz Splitters
 - RG6 Cable



Society of Cable
Telecommunications
Engineers



Verify Everything

- Check for leakage
- Verify proper splitter configuration
- Verify proper grounding and demarc layout



Society of Cable
Telecommunications
Engineers



Signal Level Issues



Possible Signal Level Issues

- Signal level too low
- Signal level too high
- Improper frequency response
- Outages



Symptoms of Low Signal Level

- **Analog Channels:**
 - Snowy picture
- **Digital Channels:**
 - Tiling
 - Freeze Frame
 - No Picture/Temporarily Off Air



Signal Level Too Low

- Verify signals at tap
- Verify appropriate attenuation through drops and passive devices
- Verify proper splitter configuration



Signal Level Too High

- Check for unnecessary amp
- Line issue

Improper Freq. Response (Cont.)

- When troubleshooting freq. response, remember:

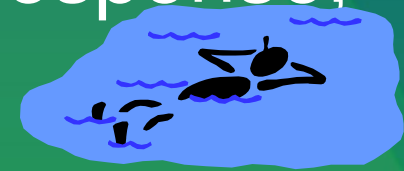

- **High frequencies can't swim.**
- (water or corrosion in drop or passive device)

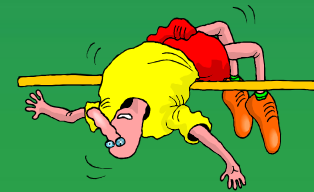

- **Low frequencies can't jump.**
- (sucked out or loose fittings, worn out barrels)



Outages

- If you suspect on outage, check signal levels at the tap first and work back toward the outlet.
- If outage exists at tap, consult supervisor for maintenance workstart. (**Remember to check multiple tap ports.**)
- If outage exists only at demarc and outlet, troubleshoot the drop and demarc.
- If outage exists only at the outlet, troubleshoot from the demarc to the outlet.



Society of Cable
Telecommunications
Engineers



Ingress



Tools

- Analog Channel:
 - Ghosting
 - Double Image
 - Lines
 - Audio Buzz / Radio Signal
- Digital Channel:
 - Tiling
 - Freeze Frame
 - No Pic
 - Temporarily off air
- SLM
- Sniffer
- Hot Drop
- 75 ohm terminator
- Addressable Box or VCR
- Test set



Society of Cable
Telecommunications
Engineers



Ingress Causes

- Damaged cable
- Bad fitting
- Loose fitting
- Push-on jumpers
- Damaged CPE
- Customer theft devices
- Damaged tap
- Damaged network
- Leakage in vicinity



Ingress Troubleshooting

- The key to ingress repair is isolating the problem.
- Quickly look the system over for obvious problems – push on jumpers, loose fittings, animal chew. Check for Leakage!
- If there is no obvious problem, use a hot drop or an SLM to isolate the problem.
 - Tap to TV
 - Tap to demarc
 - Demarc to TV



Ingress Troubleshooting

- **If you suspect ingress from the television:**
 - Place a non-locking 75 ohm terminator on the TV's cable input – if you have color, picture, or sound on any local ingress channel, the TV has direct ingress.
 - Disconnect the television and place a test set in its place – if the ingress disappears, the customer's TV has direct ingress.
- **To detect ingress on Digital Channels:**
 - Check the box's diagnostic menu.



Common Digital Box Problems

- **Yes/No on hit (usually a return path issue)**
 - High pass filter on line – (upgrades or failed self-installs)
 - Pulled out or loose fitting
 - Defective passive device
- **No Data/Guide Problems (usually signal level issue)**
 - Check signal levels.
 - Check diagnostic menu
(See DCT manual for specific errors)



Society of Cable
Telecommunications
Engineers

Common Digital Box Problems



- Tiling/Freeze Frame/No Picture/Temporarily Off Air
 - Low signal level
 - Low SNR
 - Ingress
- **Missing Channels/Premiums**
 - Low signal level
 - Low SNR Ingress
 - Back Office issue (**Call dispatch.**)