

Challenges of Launching DOCSIS 3.0 services

(Choice's experience)



Installation and configuration

DOCSIS 3.0 Components

- ◆ M-CMTS deployment
 - DTI Server
 - Edge QAM
 - Modular CMTS
- ◆ I-CMTS
 - Integrated CMTS
 - Integrated DOCSIS 3.0 QAMs

Challenges of Launching DOCSIS 3.0 services

(cont.)
(Choice's experience)

DTI Server

- ◆ What is a DTI server?
 - DTI (DOCSIS Timing Interface) synchronizes DOCSIS capable devices that do not share a common clock.
- ◆ Why is synchronization important?
 - DOCSIS devices rely on timing to know when to listen for the data that is important to them.
 - DOCSIS is a synchronous transport medium.

Challenges of Launching DOCSIS 3.0 services

(cont.)

(Choice's experience)

Edge QAM

- ◆ What is an Edge QAM?
 - It converts IP based services to Digital QAM signaling
- ◆ Why do we need to convert IP to a Digital QAM?
 - This was a way that some CMTS vendors made their equipment more capable of handling additional downstream ports on their CMTS. Additional ports could be added to the CMTS without utilizing a lot of space on the existing unit or replacing the current cards.

Challenges of Launching DOCSIS 3.0 services

(cont.)

(Choice's experience)

CMTS

- ◆ Modular vs Integrated
 - Modular
 - ◆ Pros
 - Allows use of existing equipment
 - Can use external QAM for multiple CMTSs or services.
 - ◆ Cons
 - Requires external time source
 - Requires additional cabling and combining work in the head-end
 - Integrated
 - ◆ Pros
 - Doesn't require external time source
 - No additional headend wiring required
 - ◆ Cons
 - Fork lift upgrade of line cards

Challenges of Launching DOCSIS 3.0 services

(cont.)
(Choice's experience)

Legacy Network topology

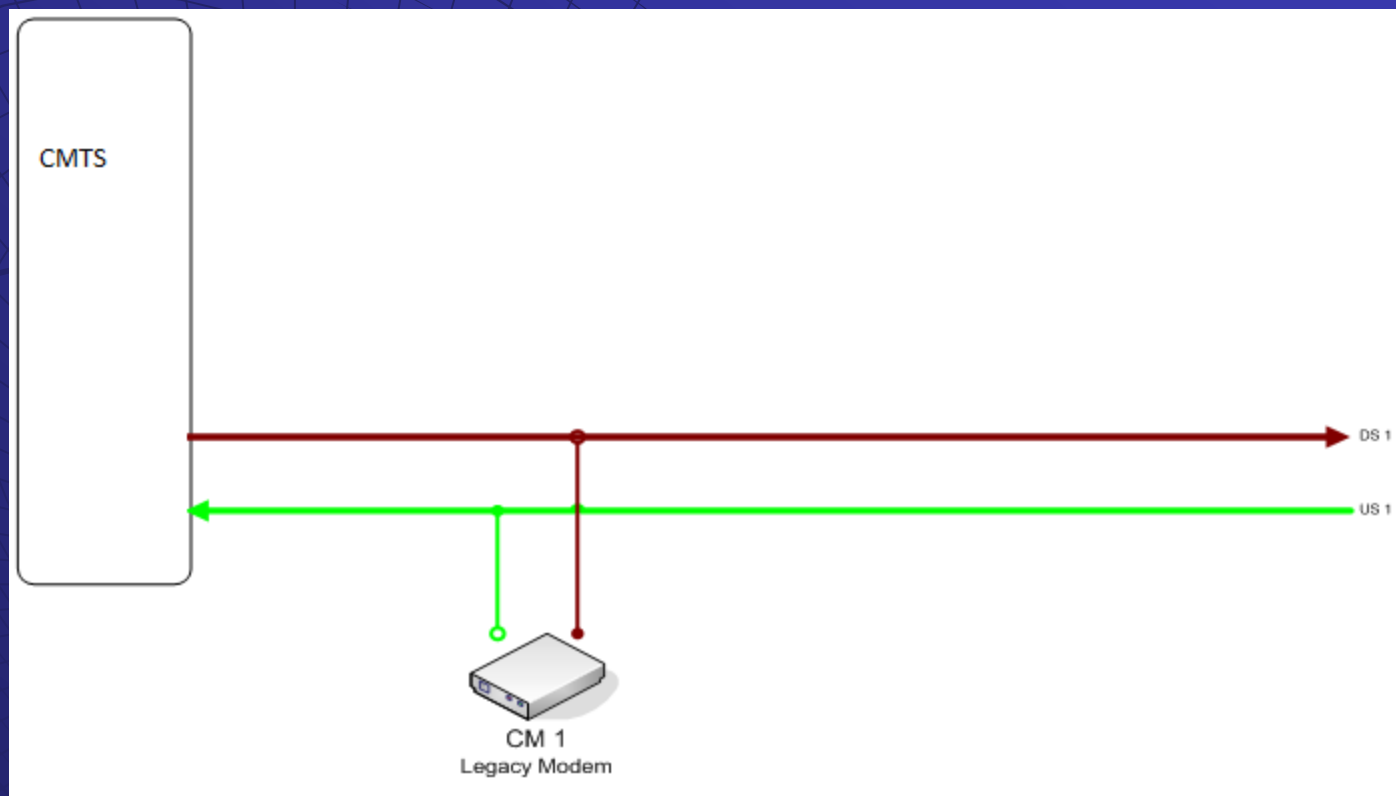

Challenges of Launching DOCSIS 3.0 services

(cont.)
(Choice's experience)

Legacy Plant Topology - Current

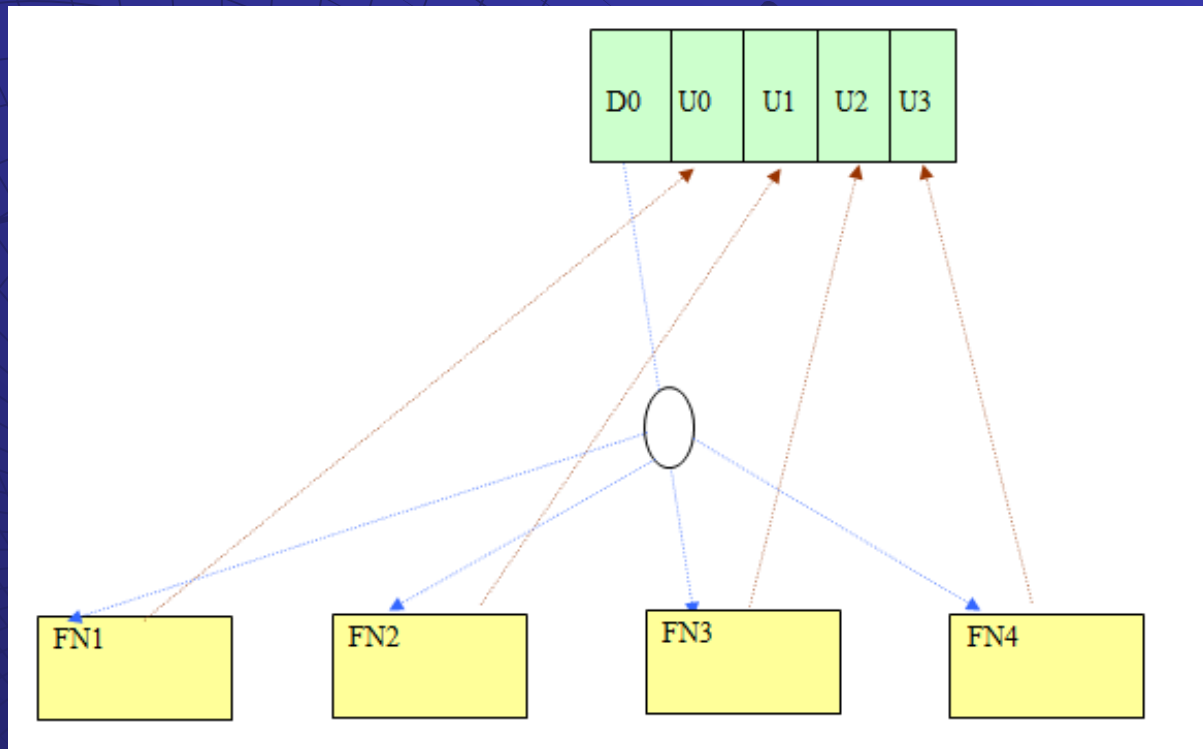

Challenges of Launching DOCSIS 3.0 services

(cont.)

(Choice's experience)

M-CMTS Downstream Channel bonding Network topology

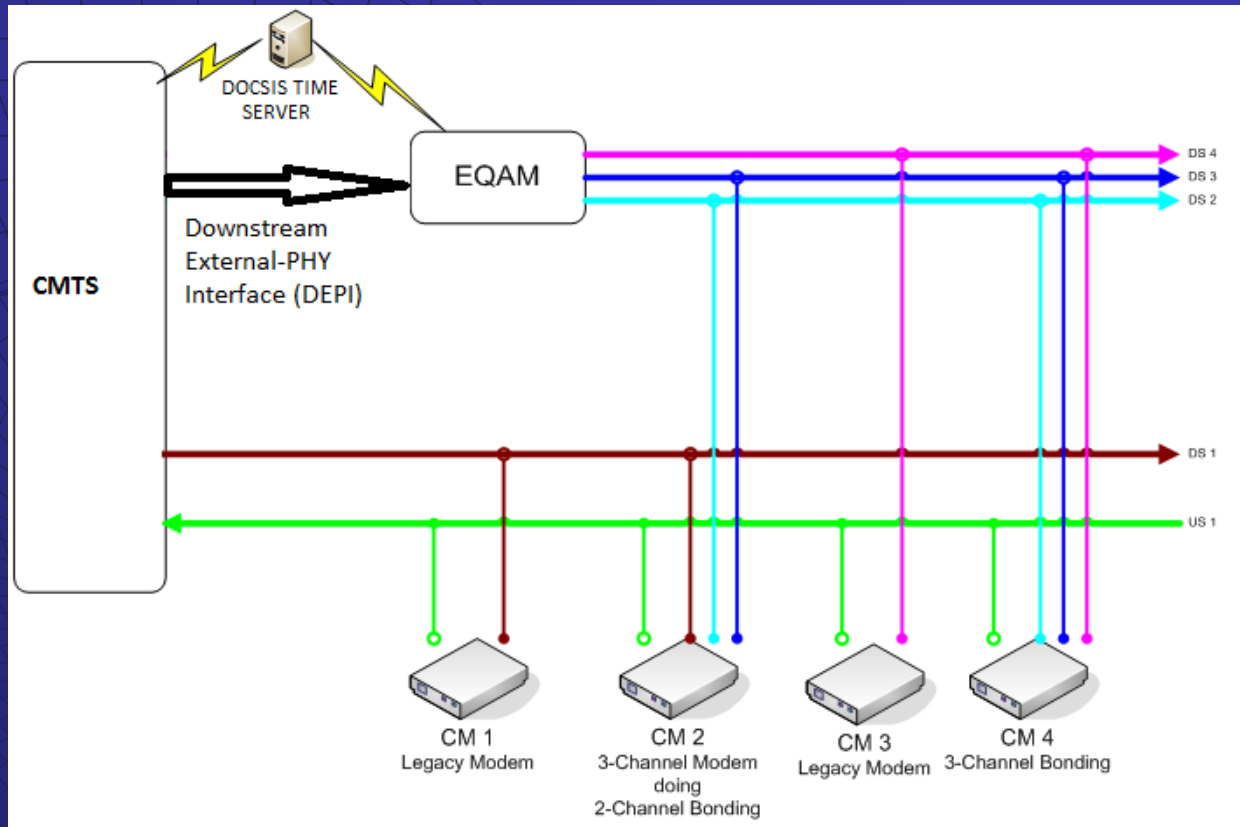

Challenges of Launching DOCSIS 3.0 services

(cont.)
(Choice's experience)

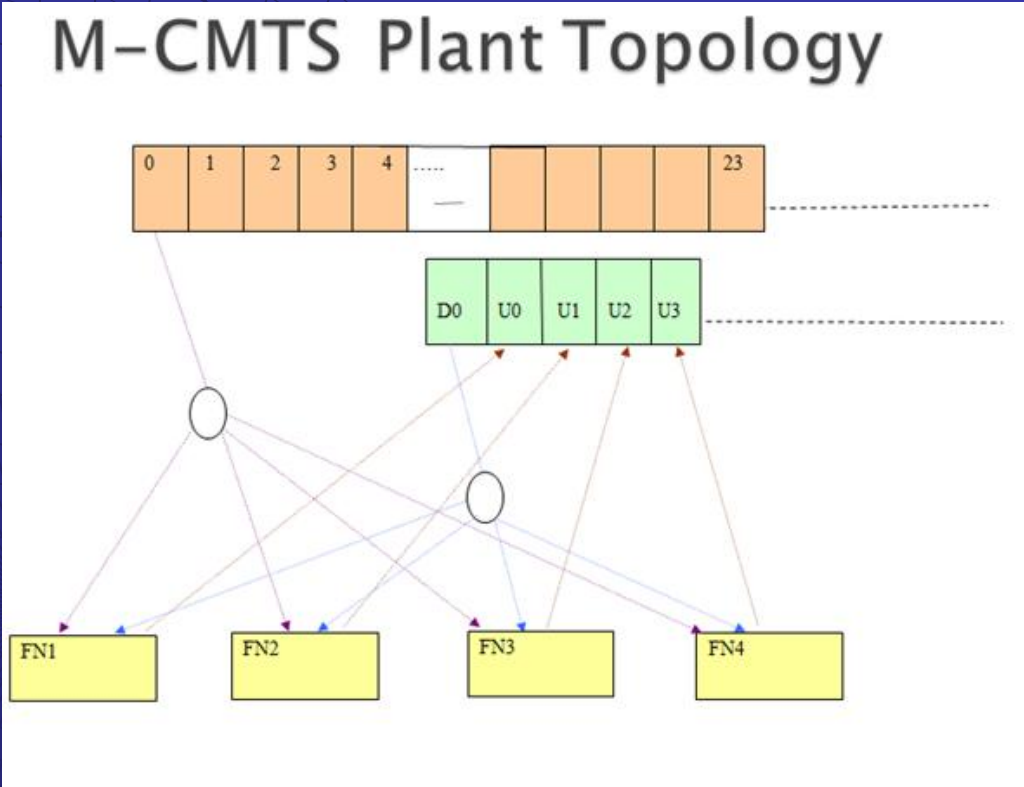

E-QAM Channels

Integrated Channels

Challenges of Launching DOCSIS 3.0 services

(cont.)
(Choice's experience)

Things to watch out for:

- ◆ Multiple QAMS per port mean less max RF-Power available for forward channels.
- ◆ Very important E-QAMS and CMTS synchronize their timing.
- ◆ No RF-Switch redundancy on E-QAMS.
- ◆ Keep an eye on CMTS CPU and memory, utilization of both increases as channels are added.
- ◆ Don't forget about CMTS and site WAN connectivity, could outgrow it real quick.
- ◆ Additional points of failure introduced when going the modular route, plan for as much redundancy as possible on external gear (DTI, E-QAMs, power-cpu, ethernet).

Challenges of Launching DOCSIS 3.0 services

Questions ???

Challenges of Launching DOCSIS 3.0 services

(Choice's experience)

Head-end Installation and
configuration

Challenges of Launching DOCSIS 3.0 services

(Choice's experience) cont.

Forward balancing

- To ensure a reliable service, forward path must comply to a set of specifications based on manufacturers technical sheets, desired signal inputs to actives, etc.
- When working with optical lasers you don't want to under drive (signal too low) or overdrive (too much signal) the optics inside the equipment.
- Manufacturer's specifications must be followed to eliminate Optical Modulation Index (OMI) errors, problems with MER and BER, Automatic Gain Control (AGC) failures, etc.

Challenges of Launching DOCSIS 3.0 services

(Choice's experience) cont.

Forward balancing (based on a specific manufacturer)

Example:

64 EIA QAM channels, 3 analog carriers

Since each 4 digital channels = 1 NTSC analog:

$$64/4 = 16$$

Adding the three analog carriers:

$$16+3 = 19 \text{ NTSC analog loading.}$$

Following the manufacturer's specifications:

$$10 \log (\text{ratio of channels})$$

Challenges of Launching DOCSIS 3.0 services

(Choice's experience) cont.

Forward balancing

Example:

As per manufacturers specifications 79 channel must be used to found the ratio of the channels.

$$10 \log (19/79) = -6.2$$

What this means is that in the broadcast port of the laser we must enter 6 dBmV above manufacturer's specs.

All analogs should read 21 dBmv on the broadcast input and digital channels must be 6dBc below analogs for 256 QAM.

Challenges of Launching DOCSIS 3.0 services

(Choice's experience) cont.

DOCSIS 3.0 Edge QAM addition impact on laser power input

- Adding new QAMs for channel bonding poses a challenge to already working forward path. Why?
 1. First, new combining was added to accommodate for the new QAM channels. This added new losses.
 2. Second, there is a difference between broadcasting and narrowcasting and how the forward laser process them.
- For Choice Cable a requirement on the forward lasers had to be met so that DOCSIS QAMs power were at proper levels and proper signal was received on the optical node.

Challenges of Launching DOCSIS 3.0 services

(Choice's experience) cont.

DOCSIS 3.0 Edge QAM additional impact on laser power input

- In our system we have two different models of forward lasers, one requires a higher broadcast/narrowcast separation (22dB), while the other one only needs 6dB separation.
- Due to the fact that new DOCSIS QAM channels were added to the system to deploy new services we had to rebalance the entire forward path.

Challenges of Launching DOCSIS 3.0 services

(Choice's experience) cont.

DOCSIS 3.0 RF Network

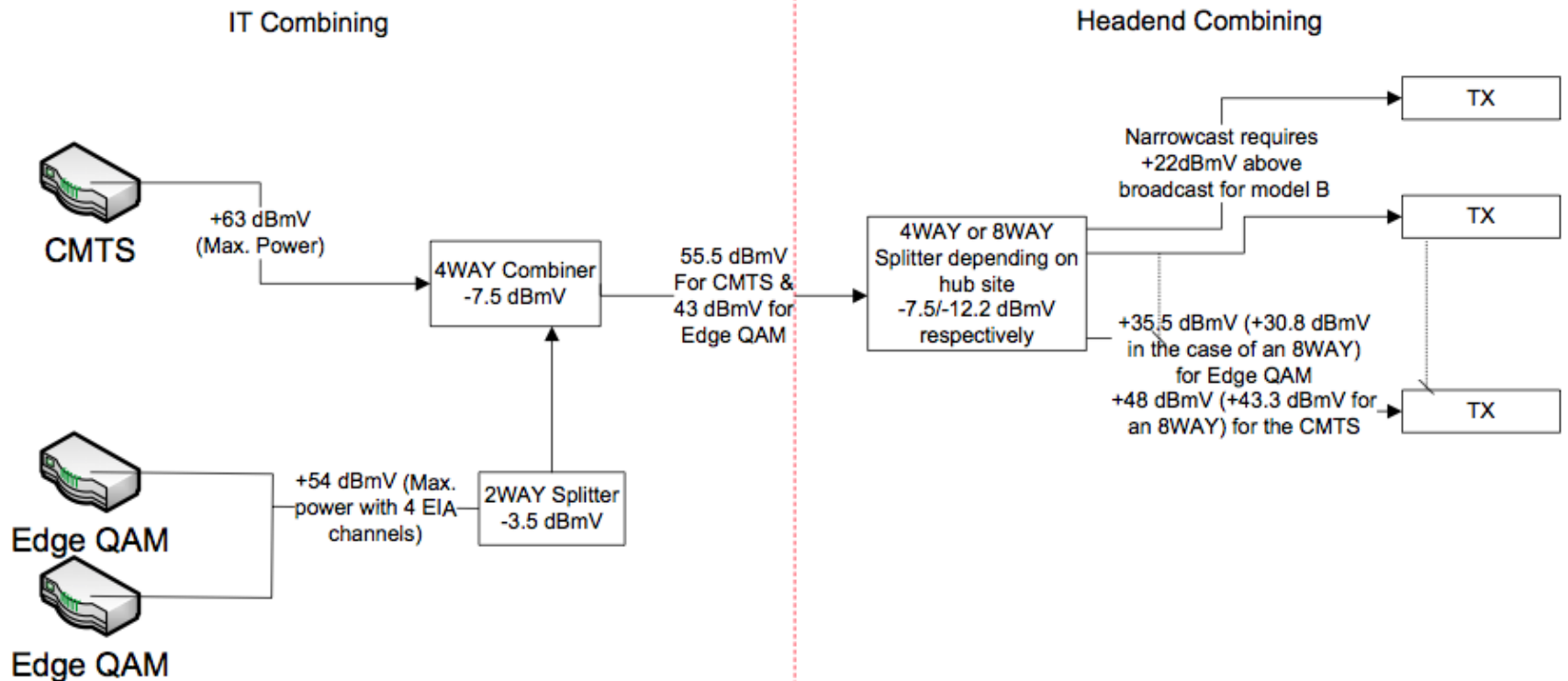

Challenges of Launching DOCSIS 3.0 services

(Choice's experience) cont.

DOCSIS 3.0 Edge QAM addition impact on laser power input

Solutions:

1. To solve our problem we divided most of the service groups which contained the model with larger separation between narrowcast and broadcast lasers in smaller groups.
2. Compensated loss by replacing 8-ways for 4-ways, etc.
3. As a way of preventing MER and BER issues fiber optic connectors were cleaned for the TX and RX.

Challenges of Launching DOCSIS 3.0 services

(Choice's experience) cont.

Return balancing

- ◆ In order to optimize the entire return path not only the field has to be balance, but also the head-end must establish its X level.
- ◆ Almost all the CPEs being deployed today offer some type of two way communication and as such we must ensure that the link between the customer and the head-end happens.
- ◆ Return path is a bit more difficult to handle than forward because of all the impairments that can happen between a customer's drop and the head-end.
- ◆ Loose connectors, electrical lamps, welding shops and other day to day use of electronics can cause service interruptions in the return path.
- ◆ Good return balancing combine with proper plant maintenance can overcome many of these issues.

Challenges of Launching DOCSIS 3.0 services

(Choice's experience) cont.

Return balancing

- We balanced our returns the following way:
 - Generate a CW carrier from the node. Use return's input test point.
 - In the head-end, measure the amplitude of this CW carrier at the input of the CMTS.
- By doing it this way we eliminate the confusion of the plenty of test points in the head-end.
- We also have a more accurate reading on the amount of power into the CMTS.

Challenges of Launching DOCSIS 3.0 services

(Choice's experience) cont.

Questions ??????????

Challenges of Launching DOCSIS 3.0 services

(Choice's experience) cont.

Network Considerations

- ◆ Node Alignment.
- ◆ Forward and Return Sweep.
- ◆ Achieving best NPR results on your return TX.
- ◆ FP v.s DFB Lasers (return transmitters).
- ◆ Have an aggressive CLI program.
- ◆ Begin to look at CWE (Code Word Error) or upstream bit error rate.
- ◆ Consider eliminating 26 value taps in order to meet maximum transmit power levels.

Challenges of Launching DOCSIS 3.0 services

(Choice's experience) cont.

Return balancing

- ◆ We balanced our returns the following way:
 1. Generate a CW carrier from the node. Use return's input test point.
 2. Ensure you are receiving the appropriate light levels at the return receiver.
 3. Verify proper output RF levels on output of receivers.
 4. By way of using passive devices pad accordingly to reach CMTS with proper RF level.
 5. At the input of the CMTS port, measure the amplitude of this CW carrier, it must be 0 dBmV.
- ◆ By doing it this way we eliminate the confusion of many test points in the head-end.

Challenges of Launching DOCSIS 3.0 services

(Choice's experience) cont.

Hub RX Output Level

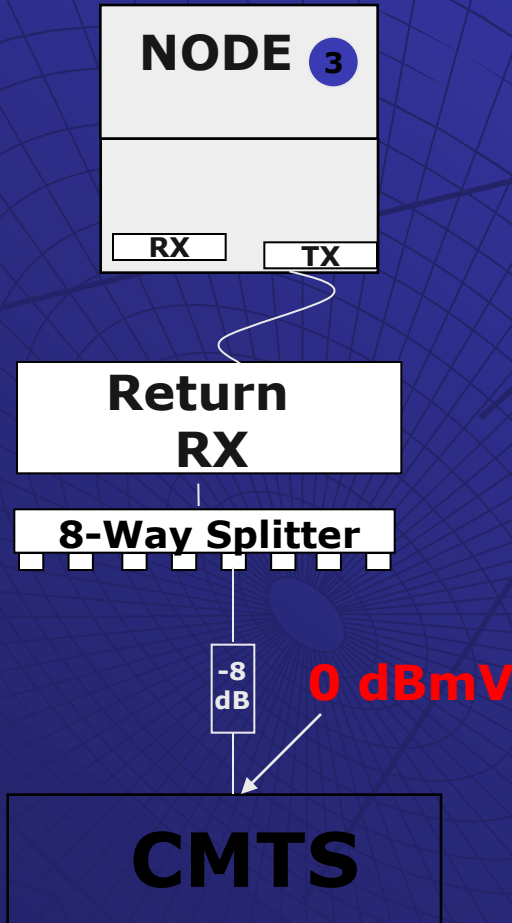

The Hub RX output is, by design, =19 dBmV (at the 8-way splitter port) in this example.

This level has already been set-up (when optical link was set-up.)

Challenges of Launching DOCSIS 3.0 services

(Choice's experience) cont.

Balancing Amplifiers - Forward Sweep

Balancing amplifiers using tilt only

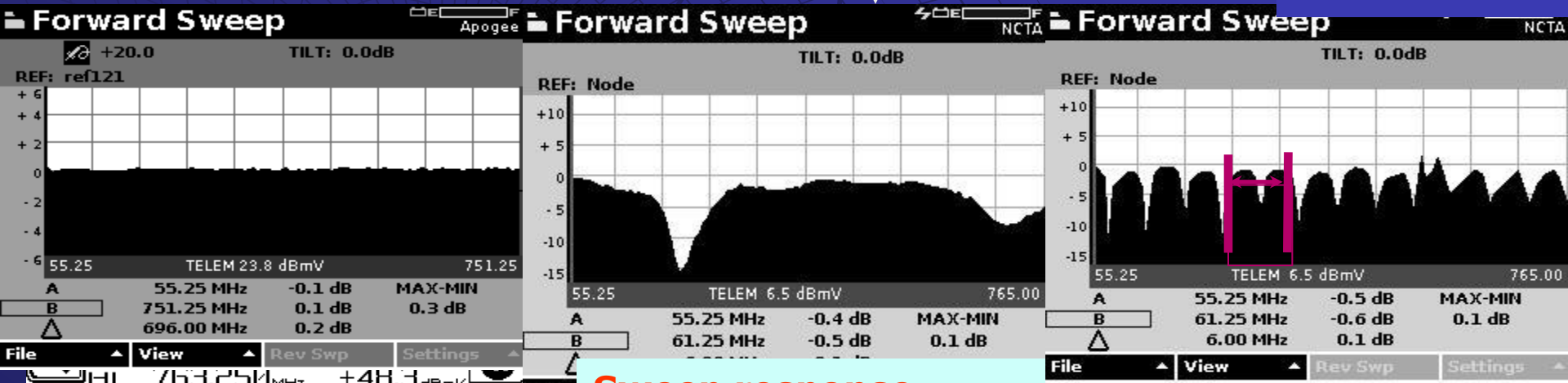
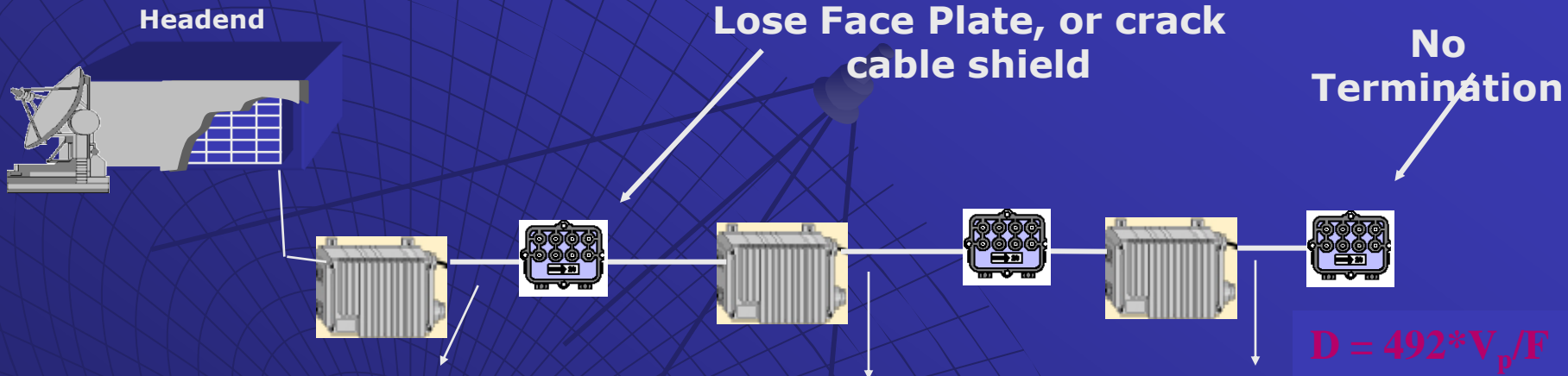

Node Reference Signal

Sweep response with a Resonant Frequency Absorption

Sweep response with standing waves

Challenges of Launching DOCSIS 3.0 services

(Choice's experience) cont.

Achieving best NPR results.

Carrier-to-Noise*

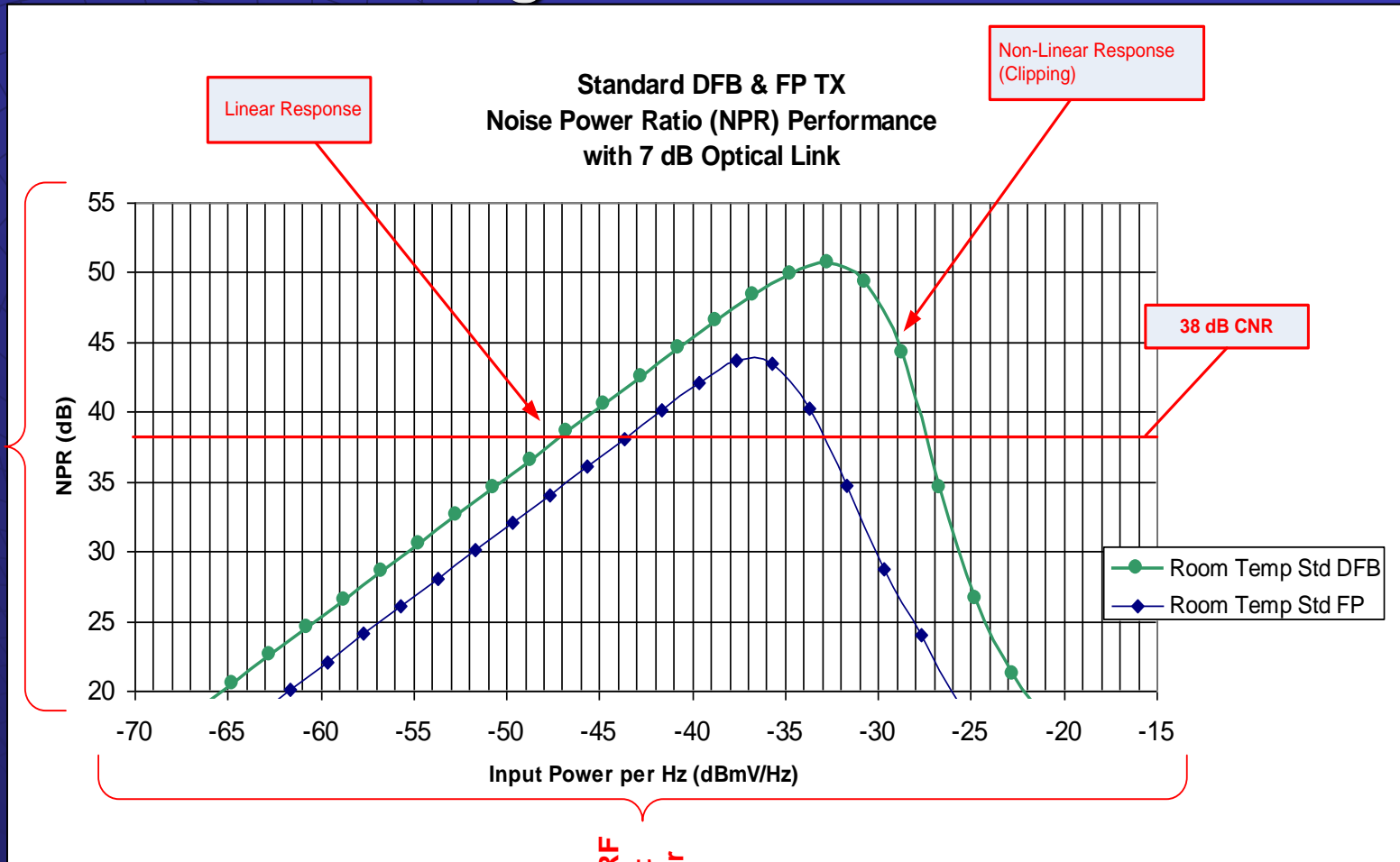

Total RF
Input
Power

Challenges of Launching DOCSIS 3.0 services

(Choice's experience) cont.



Installation, drop configuration and channel testing.

Challenges of Launching DOCSIS 3.0 services

(Choice's experience) cont.

Verifying signal levels at the tap.

Making sure you establish channel bonding from the beginning.

The importance of good installation practices.

Configuring signal distribution inside the Customer's Home.

Digital measurements at the CPE.

Finding the ideal transmit level for a cable Modem.

Challenges of Launching DOCSIS 3.0 services

(Choice's experience) cont.

Making sure you establish channel bonding from the beginning.

- ◆ Installation
 - Cable modem statistics
 - Throughput

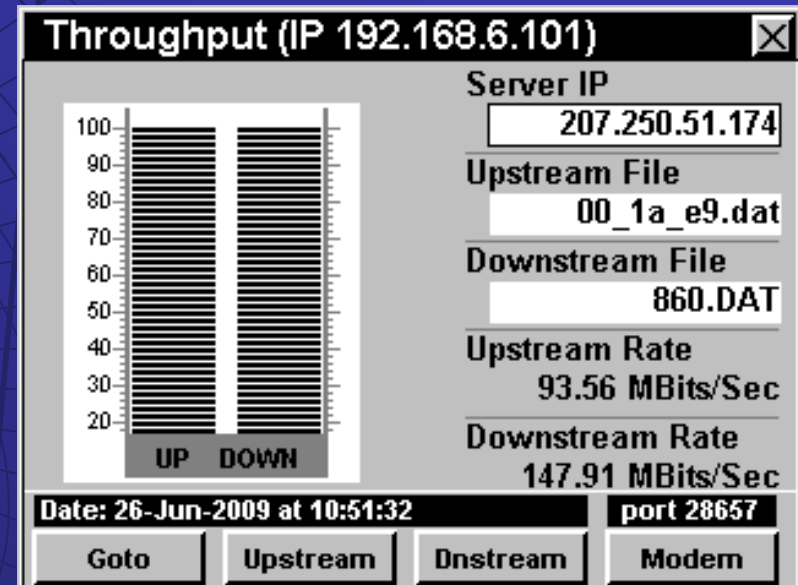
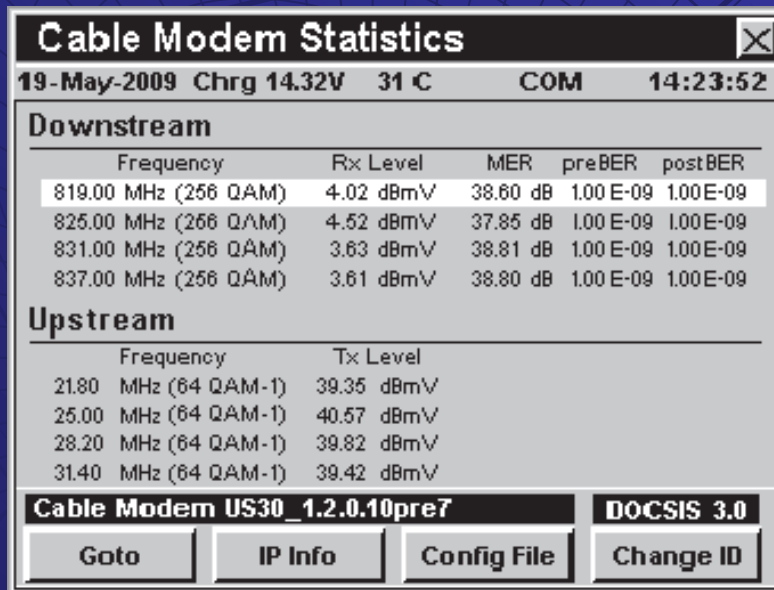

Challenges of Launching DOCSIS 3.0 services





(Choice's experience) cont.

- ◆ The importance of good installation practices.

- 1- Follow proper design, avoid cascading splitters.
- 2- If using house amplifiers be aware of return loss.
- 3- Ensure all connectors are properly tightened.
- 4- Test for signal leakage.
- 5- Verify signal levels.
- 6- Complete home certification.

Challenges of Launching DOCSIS 3.0 services

(Choice's experience) cont.

▶ docsis		← DE <input type="checkbox"/> F NCTA	
	PASS Cable Modem	HSD DOC256	CH 086
test complete			
downstream		6MHz QAM256	597.000 MHz
	LEVEL	1.4 dBmV	
	MER	34.3 dB	MER Headroom 2.3 dB
	BER estimated	1.0E-9 PRE	1.0E-9 POST
upstream		3.2MHz QPSK	34.000 MHz
	LEVEL	51.8 dBmV	LEVEL Headroom 6.2 dB
File	▲	View	▲
Limits	▲	Settings	▲

Challenges of Launching DOCSIS 3.0 services

(Choice's experience) cont.

The real issue is drop noise

(noise coming from the subscriber premise).

- ◆ The subscriber drop typically generates the greatest amount of noise in the HFC plant.
- ◆ Poorly made F-connectors, loose fittings, electrical interference coming from unshielded 75ohms connectors behind TV sets, unauthorized activity, etc.
- ◆ Addressing subscriber originated noise is the quickest and surest way to improve the overall Node health on your network.
- ◆ Ensure you have a well organize CLI program.

Challenges of Launching DOCSIS 3.0 services

(Choice's experience) cont.



Challenges of Launching DOCSIS 3.0 services

(Choice's experience) cont.



Challenges of Launching DOCSIS 3.0 services

(Choice's experience) cont.

Questions ???????????