



Cisco Support Community Expert Series Webcast:

Cable Modem Termination Systems (CMTS): Architecture, Configuration, and Troubleshooting

Eric Bautista
Customer Support Engineer

September 12, 2012

Cisco Support Community – Expert Series Webcast

- Today's featured expert is Cisco Support Engineer **Expert**
- Ask him questions now about CMTS



Eric Bautista

Thank You for Joining Us Today

Today's presentation will include audience polling questions

We encourage you to participate!



Thank You for Joining Us Today

If you would like a copy of the presentation slides, click the PDF link in the chat box on the right or go to

<https://supportforums.cisco.com/community/netpro/service-providers/video>

Or, <https://supportforums.cisco.com/docs/DOC-26916>



Thank You for Joining Us Today

Everyone who joins today's webcast will receive:

125 Cisco Preferred Access Points!

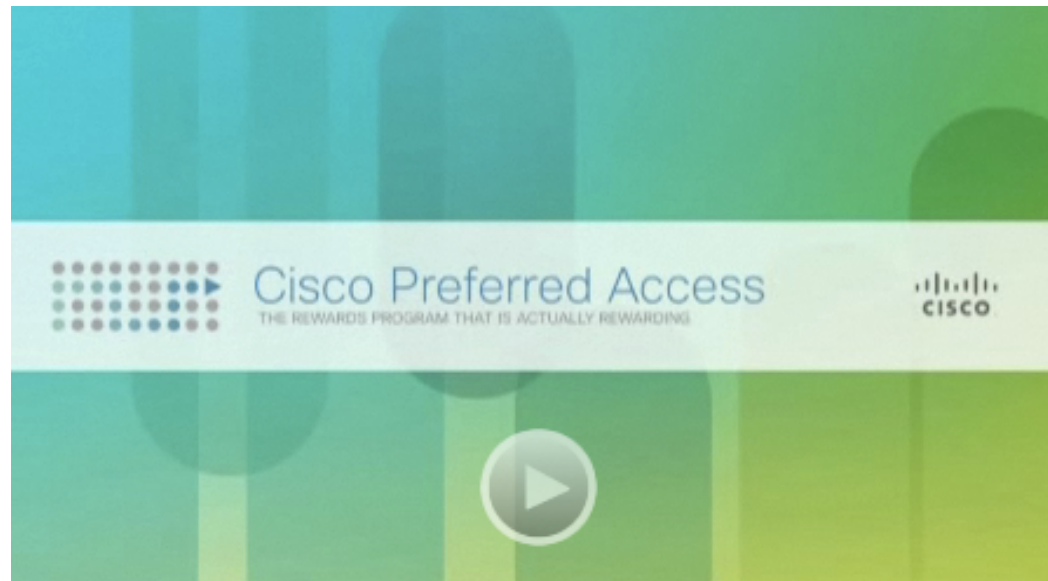

Polling Question 1

What experience do you have with the Cisco CMTS platforms?

- a) Basic configuration and troubleshooting.
- b) Expert level configuration and troubleshooting.
- c) I work on adjacent devices (i.e. EQAM, DNCS, DCM, eMTA's, STB's).
- d) None

Submit Your Questions Now!

Use the Q&A panel to submit your questions. Experts will start responding those





Cisco Support Community Expert Series Webcast:

Cable Modem Termination Systems (CMTS): Architecture, Configuration, and Troubleshooting

Eric Bautista

Customer Support engineer

September 12, 2012

Skill Based Objective

- Given basic information and “show” commands from a Cisco CMTS, the learner will be able to identify what platform and modules are being used. They will also be able to describe the HFC topology and describe the current state of the cable interfaces.

Agenda

- Role of a CMTS in a cable Multiple System Operator (MSO) network
- I-CMTS vs.. M-CMTS
- Brief overview of Cisco’ s CMTS product family
 - uBR7200 product line overview
 - uBR10K product line overview
- Basic configuration and show commands
- DOCSIS 3.0 Cable Bonding
- Q&A



Role of a CMTS

What is a CMTS

- CMTS stands for Cable Modem Termination System
- The CMTS is a provider edge system which interfaces the RF cable plant side to the provider IP core network
- CMTS' s allow Service Providers to offer broadband High Speed Data (HSD) and other IP based services to the end subscribers connected to their cable network – including Voice and Video.
- DOCSIS (*Data Over Cable Service Interface Specification*): Defines interface requirements for cable modems involved in high-speed data delivery over cable's hybrid fiber-coaxial plant.

Cable Broadband Architecture

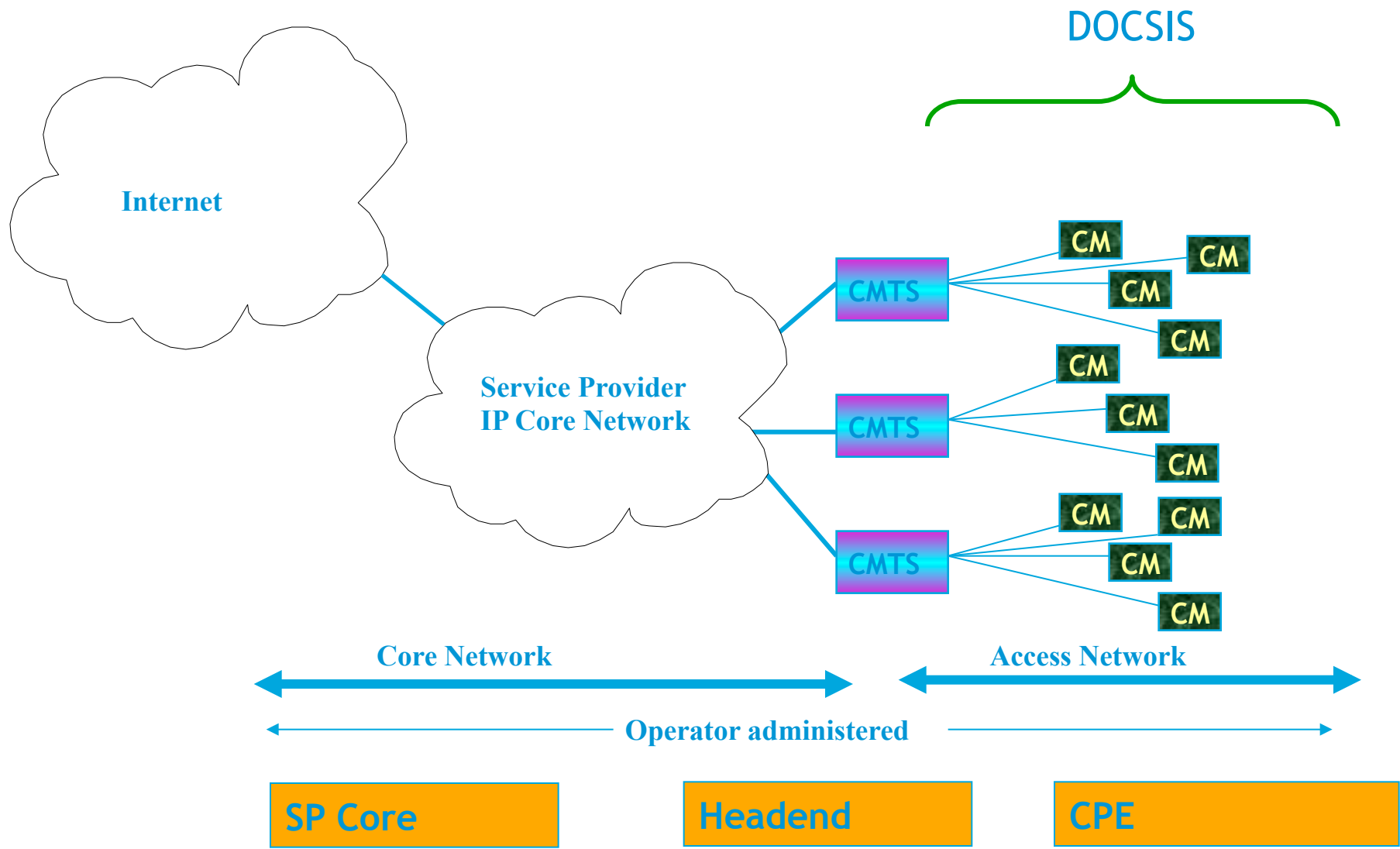

Functions performed by a CMTS

- Provides network side interfaces (i.e. Gigabit Ethernet) to the provider IP network
- Provides RF side interfaces to the cable plant.
- A “legacy” RF side interface consists of one downstream channel and multiple upstream channels
 - Downstream channels carry traffic from the CMTS to the cable modems
 - Upstream channels carry traffic from the cable modems to the CMTS
- CMTS performs switching / routing functionality between the RF side and network side interfaces
 - This switching/routing function is very similar to that of a typical IP router

✧ MAC Domain

Why is it important to describe how a CMTS is set-up?

- You can better isolate what may be causing the issue.
- You can better collaborate with Cable engineers.
- End-to-end lab recreates.



Integrated CMTS (I-CMTS)

VS..

Modular CMTS (M-CMTS)

I-CMTS

- Integrated CMTS

- The contents of a downstream channel are directly modulated and transmitted by the Downstream RF port.

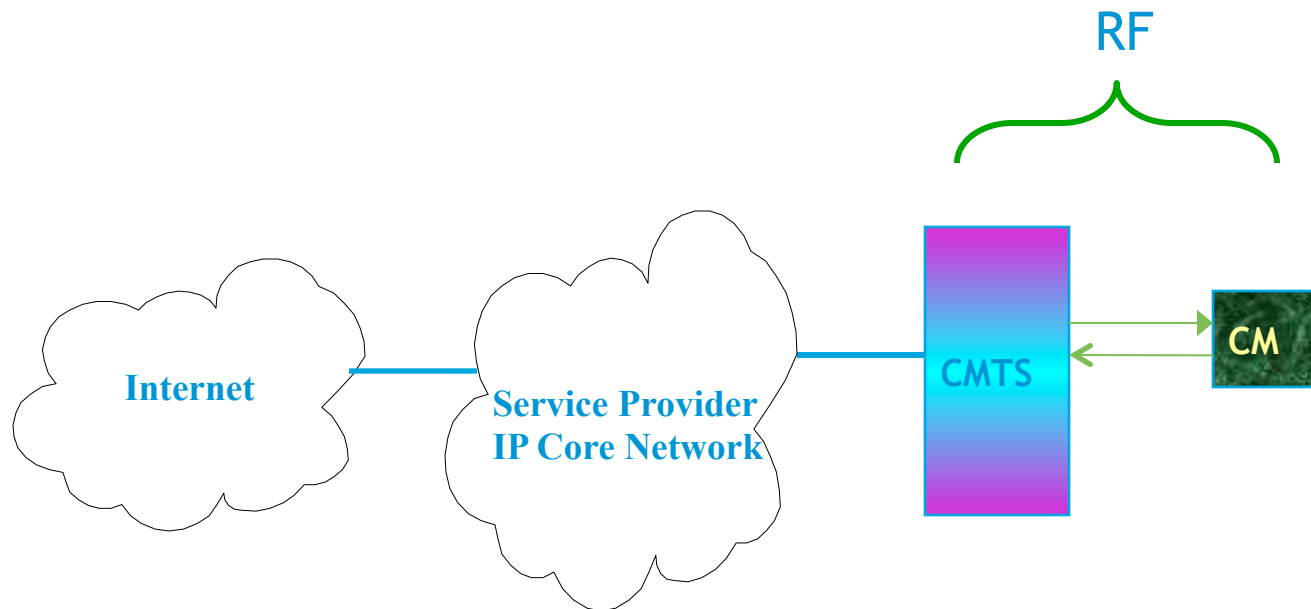

M-CMTS

- Modular CMTS

- The contents of a downstream channel are encapsulated into a DEPI Tunnel for transmission.
- DEPI = Downstream External Physical Interface
- EQAM = Edge Quadrature Amplitude Modulation

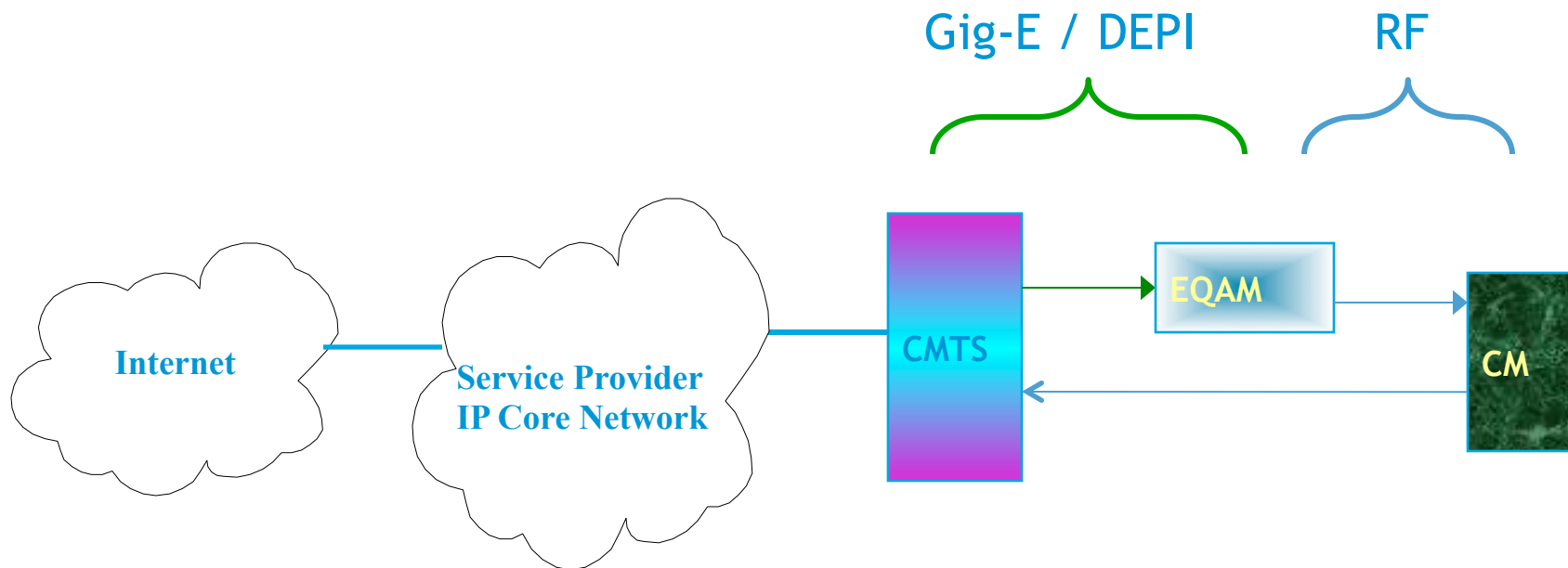



Brief Overview of Cisco's CMTS Product Family

Cisco CMTS Products

- Cisco uBR7225VXR Universal Broadband Routers
 - Mid to Entry level CMTS
 - Up to 16 upstream and 16 downstream ports in a 2-RU form factor
- Cisco uBR7246VXR Series Universal Broadband Routers
 - High performance, communications-grade CMTS
 - Up to 32 upstream and 32 downstream ports in a 6-RU form factor
- Cisco uBR10000 Series Universal Broadband Routers
 - Highest performance and port capacity
 - Up to 480 upstream and 576 downstream ports in an 18-RU form factor

uBR7225VXR

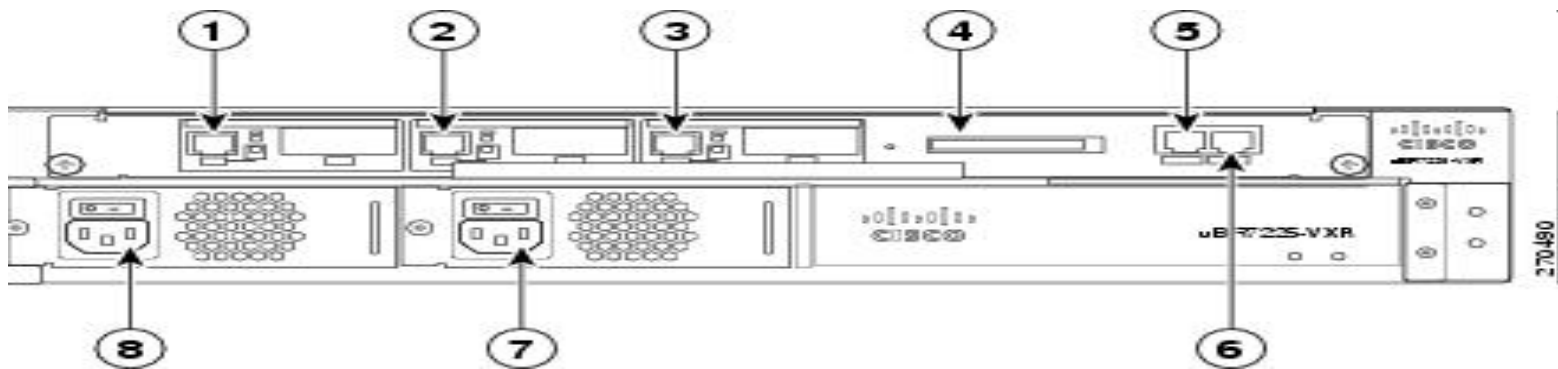

- | | | | |
|---|---------------------------|---|-------------------------|
| 1 | Gigabit Ethernet 0/1 | 5 | Console port |
| 2 | Gigabit Ethernet 0/2 | 6 | Auxiliary port |
| 3 | Gigabit Ethernet 0/3 | 7 | AC-input power supply 2 |
| 4 | Network processing engine | 8 | AC-input power supply 1 |

Cisco uBR7225VXR CMTS

- uBR7225VXR CMTS chassis has two slots for Cable interface line cards and one slot for Network Processing Engine (NPE).
- Chassis mid-plane bridges the PCI buses from cable interface line cards to the Network Processing Engine (NPE-G1 & NPE-G2)
- Mid-plane supports an aggregate bandwidth of 600 Mbps
- Supports both DOCSIS & Euro-DOCSIS operation
- It supports the following cable line cards:
 - **UBR-MC16U, UBR-MC28U and uBR-MC88V**
 - Cisco uBR7225VXR E-28U BPE (compatible with the uBR7225VXR chassis only)
 - Cisco uBR7225VXR E-16U BPE (compatible with the uBR7225VXR chassis only)

Network Processing Engine for uBR7225VXR

- NPE performs the following system management functions:
 - Sending and receiving routing protocol updates
 - Managing tables, caches, and buffers
 - Monitoring interface and environmental status
 - Providing Simple Network Management Protocol (SNMP) management and console/Telnet interface
 - Accounting and switching of data traffic
- Part Numbers:
 - **uBR7200-NPE-G1**
 - **uBR7200-NPE-G2**

Cable line Cards for uBR7225 VXR

- UBR-MC16U, UBR-MC28U and uBR-MC88V
- 1X6 cards support a single cable mac domain with one downstream and six upstream channels
- 2X8 cards support two cable mac domains each with one downstream and four upstream channels
- 8x8 cards support two cable mac domains which can be configured with various combinations of downstream and upstream channels.

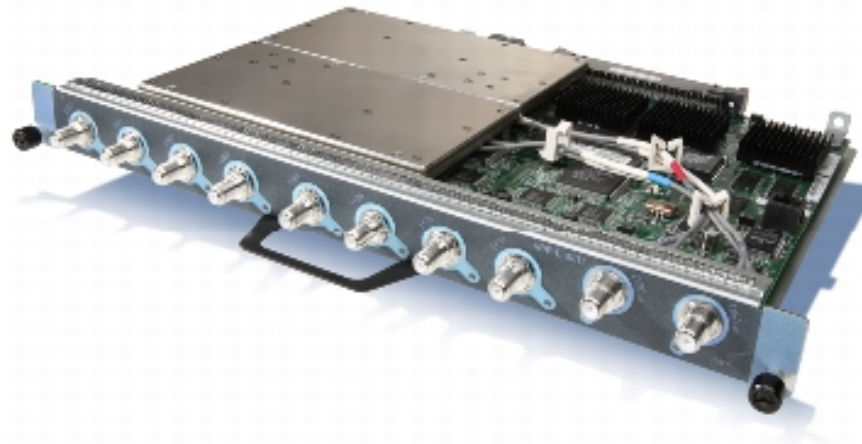

uBR7246VXR

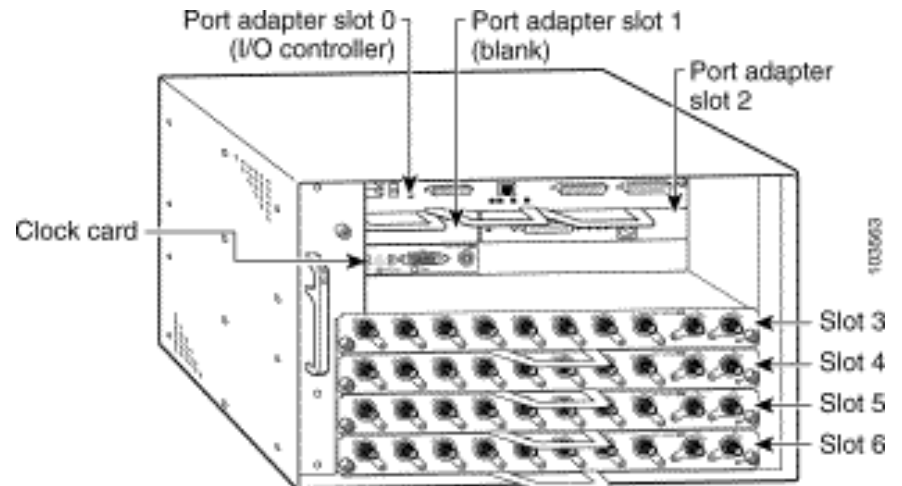

- Chassis based mid-range CMTS
- Chassis supports a total of four cable line cards
- Supports two port adapters for IP core side connectivity
- Supports NPE-G2 and NPE-G1 & NPE-400 (Older versions of IOS software supported NPE-225 as well)
- Optional I/O controller (Not a requirement for NPE-G1 &G2)
- One optional cable clock card

uBR7246VXR

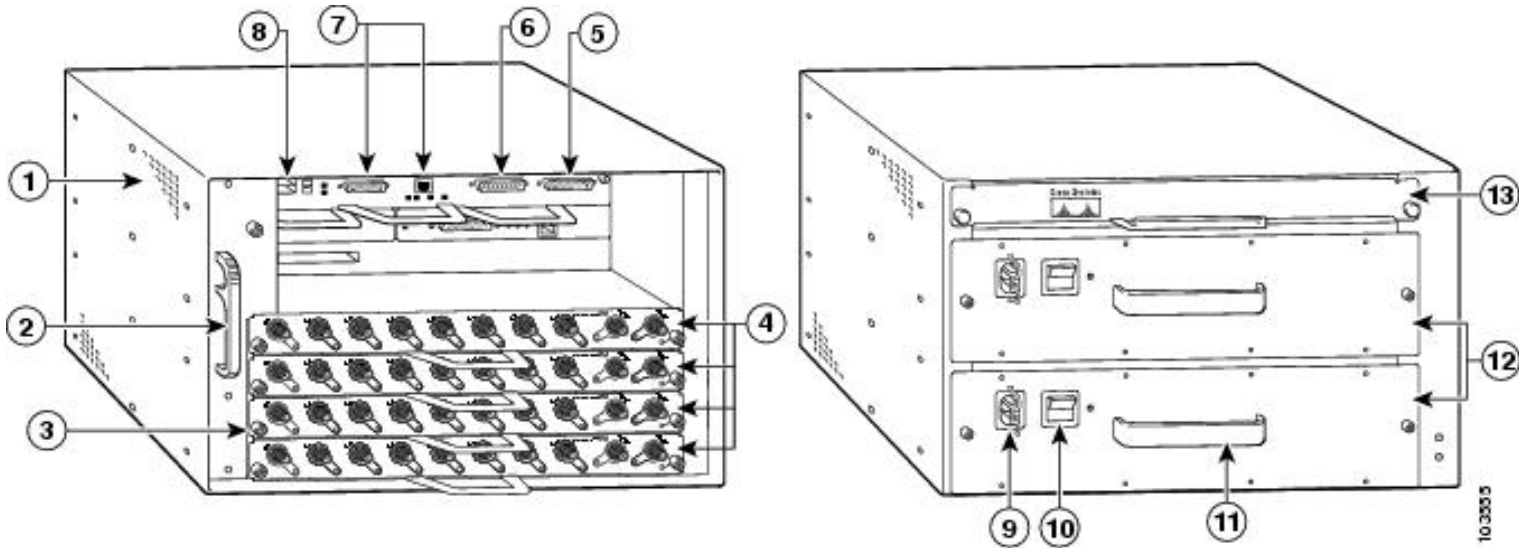

- | | | | |
|---|--|----|---|
| 1 | Internal fans | 9 | Auxiliary port |
| 2 | Clock card | 10 | Optional Fast Ethernet port (M11 and RJ-45 receptacles) |
| 3 | Fan tray handle | 11 | PCMCIA slots |
| 4 | Captive installation screws (line cards) | 12 | AC plug ¹ |
| 5 | Cable interface line cards | 13 | Power switch |
| 6 | Port adapters | 14 | Power supply handle |
| 7 | I/O controller | 15 | AC-input power supply |
| 8 | Console port | 16 | Network processing engine (NPE) |

Cable Line Cards for uBR7246 VXR

- **UBR-MC16U/X** : 1 DS port and 6 US ports. One 1X6 RF mac-domain. Built In or external upconverter.
- **UBR-MC28U/X** : 2 DS ports and 8 US ports. Two 1X4 RF mac-domains. Built in or external upconverters.
- **uBR-MC88V** : 2 DS ports and 8 US ports. 2 RF mac-domains.
- Older Cable Cards : MC16C, MC16S, MC16E, MC11C, MC14C etc.

uBR10K series – A new class of CMTS

- DOCSIS 1.1, DOCSIS 2.0, & DOCSIS 3.0 Qualified
- Optimized for aggregation
 - Increases intelligence at edge of the network
 - Balanced system, maximizes useful capacity where needed
 - Offers both Processor and Linecard Redundancy
- Future Scalability
 - Passive point-point Midplane
 - Fully upgradeable processors, WAN interfaces, RF cards
 - Addresses potential bottlenecks

uBR10012 Components

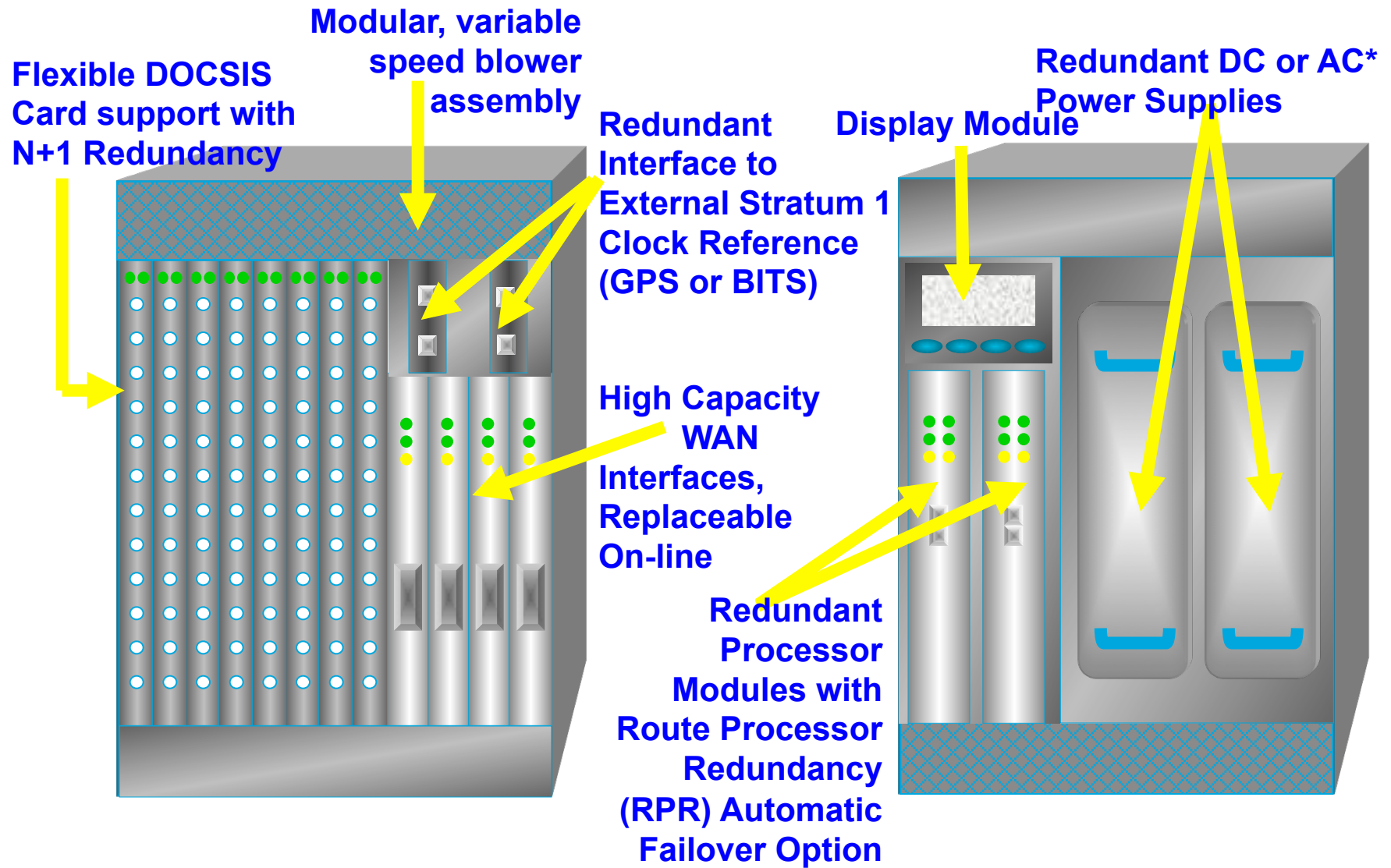

Chassis Slot Numbering

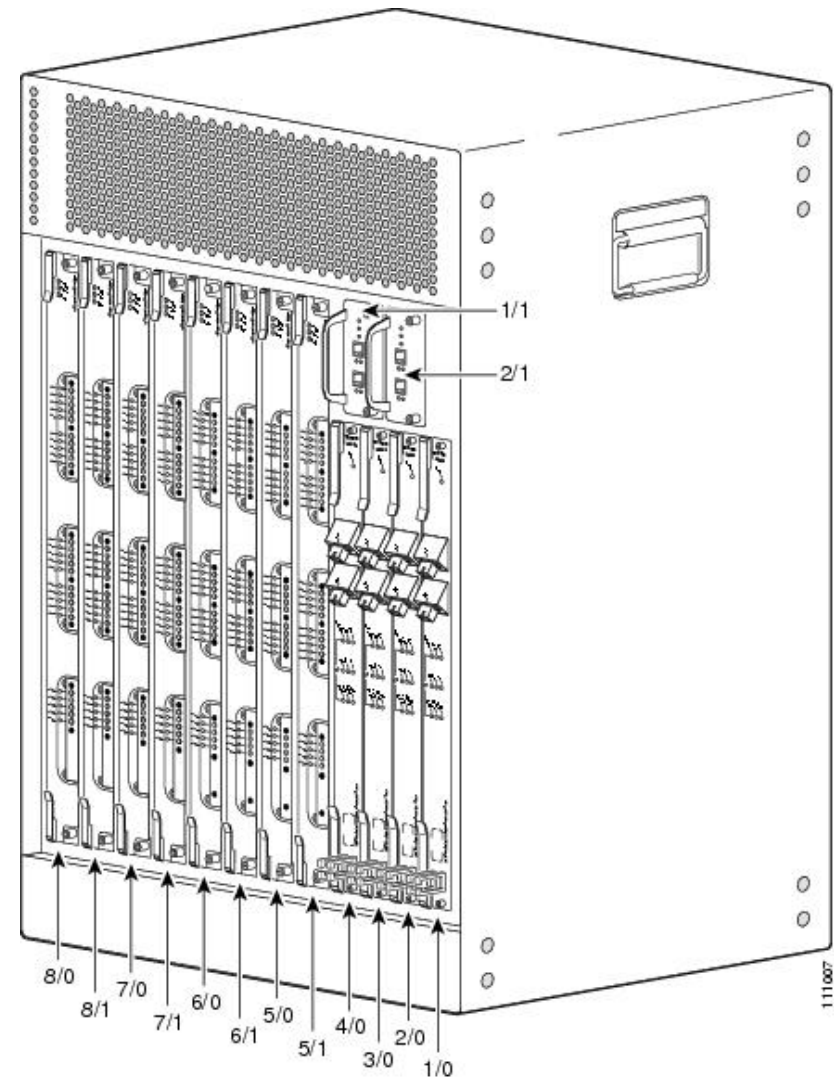
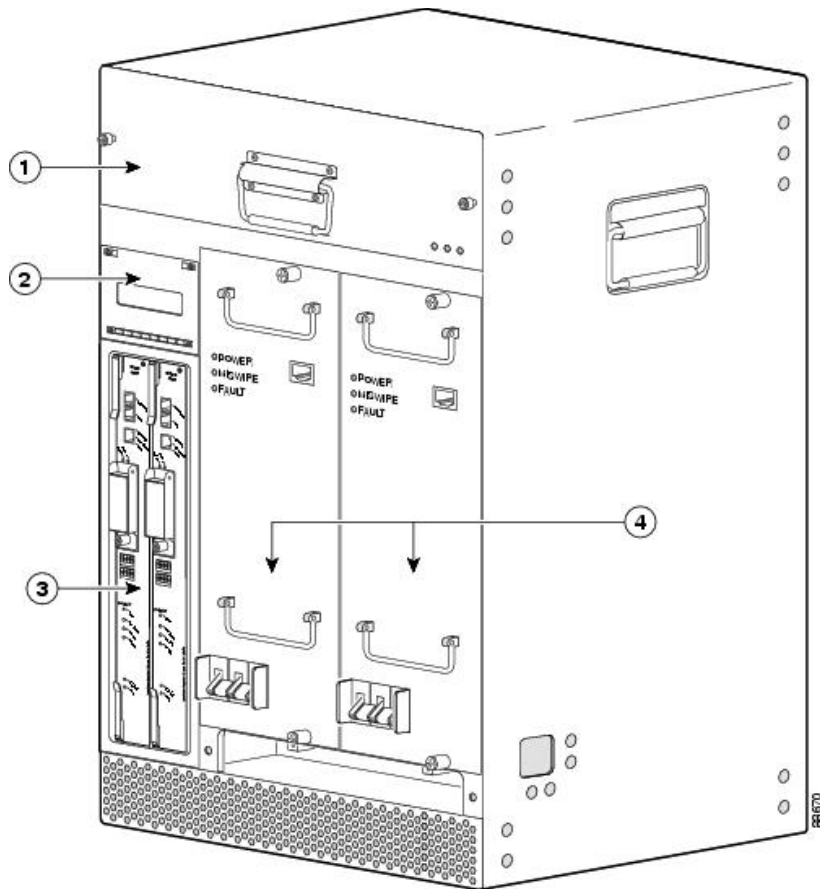

- | | | | |
|---|---------------------|---|--------------------|
| 1 | Fan assembly module | 3 | Two PRE modules |
| 2 | LCD module | 4 | Two DC PEM modules |

uBR10k Performance Routing Engines

- The PRE module is a single-slot module used with the Cisco uBR10012 universal broadband routers.
- The PRE performs all Layer 2 and Layer 3 packet routing and forwarding.
- PRE modules support redundant operation when installing two PRE modules in a Cisco uBR10012 chassis. If the active PRE fails, the standby PRE automatically takes over operation of the chassis.



- Part Numbers:

- **ESR-PRE1**

- **ESR-PRE2**

- **ESR-PRE4**

PRE4 Faceplate

Figure 1 Performance Routing Engine Front Panel

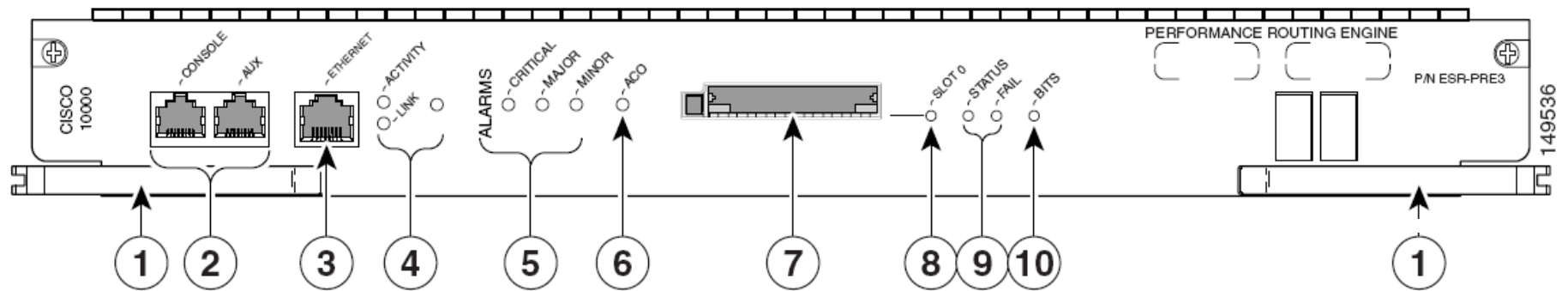

1	Ejector Levers	6	ACO (Alarm Cut-off Button)
2	Console and Auxiliary Ports	7	CompactFlash Slot, Disk0
3	Network Management Ethernet (NME) Port	8	Slot0 (Disk0) LED
4	NME Activity and Link LEDs /Push-button reset	9	Status, Fail LEDs
5	Alarms: Critical, Major, Minor	10	Building Internal Timing Source (BITS) LED (c10k only)

PRE4 Faceplate

Figure 1 Performance Routing Engine Front Panel

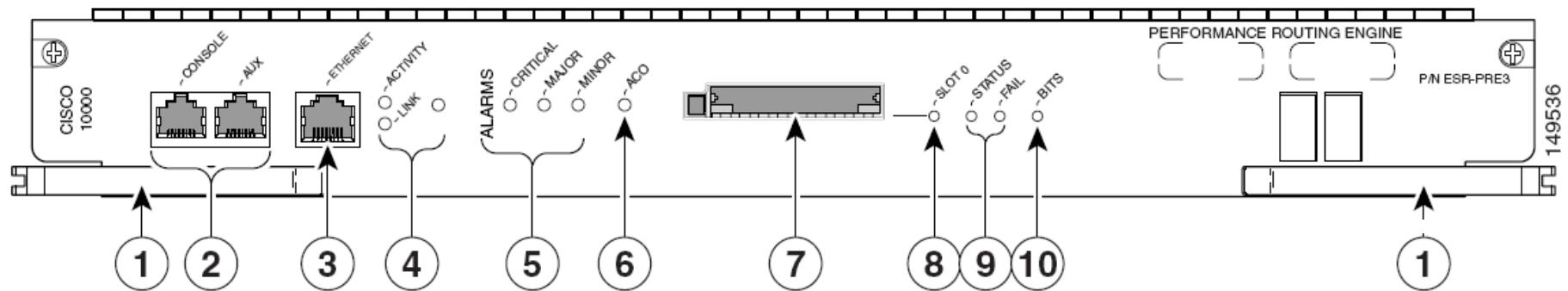

PRE4 Connectors

The front panel on the PRE4 contains three ports with RJ-45 connectors.

•Console port (CONSOLE)

•This asynchronous serial port is used to connect a terminal to the PRE4 for local administrative access.

•Auxiliary port (AUX)

•This asynchronous serial port is used to connect a modem to the PRE4 for remote administrative access.

•NME Port

•This Ethernet port is used to connect the PRE4 to a Fast Ethernet port. To be used for management purposes, only.

CompactFlash Card Slot

The external CompactFlash slot can store the Cisco IOS image or a system configuration file on a flash memory card. The system can also boot from the software stored on the flash memory card.

Cable line Cards for uBR10k

- **UBR10-5x20S-D, UBR10-5x20U-D, UBR10-5x20H-D**
 - Five downstream (DS) ports and twenty upstream (US) ports.
 - 5x20 cards support up to five cable MAC domains.
 - Typically each mac domain consists of 1 downstream and 4 upstream channels.
- **UBR-MC20X20V**
 - Five downstream (DS) ports and twenty upstream (US) ports
 - The line card supports five cable MAC domains, and the 20 DS and 20 US channels are dynamically associated with any of these five MAC domains.
 - Each of the US ports support either two-frequency stacked US channels across ten ports or a single US channel across twenty ports.
 - Each of the DS ports supports four-frequency stacked channels across five ports.
- **uBR-MC3GX60V**
 - 72 downstream (DS) and 60 upstream (US) channels
 - The line card supports 15 cable MAC domains.
 - The DS and US channels can be associated with any of these 15 MAC domains.
 - Each MAC domain supports a maximum of 32 DS and 8 US channels.
 - M-CMTS

MC5X20S/U/H Cable Line Card

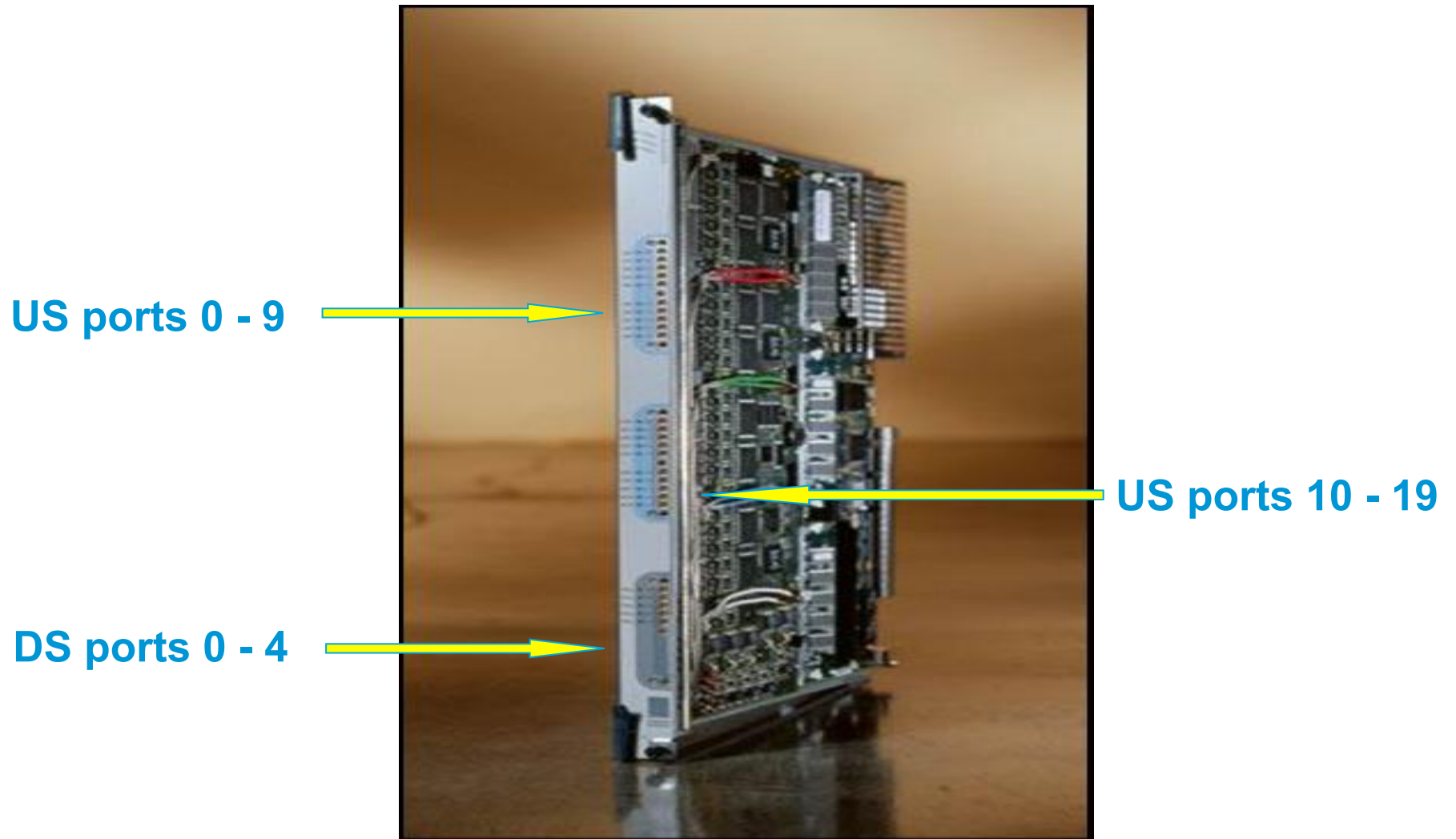

uBR-MC3GX60V Cable Line Card

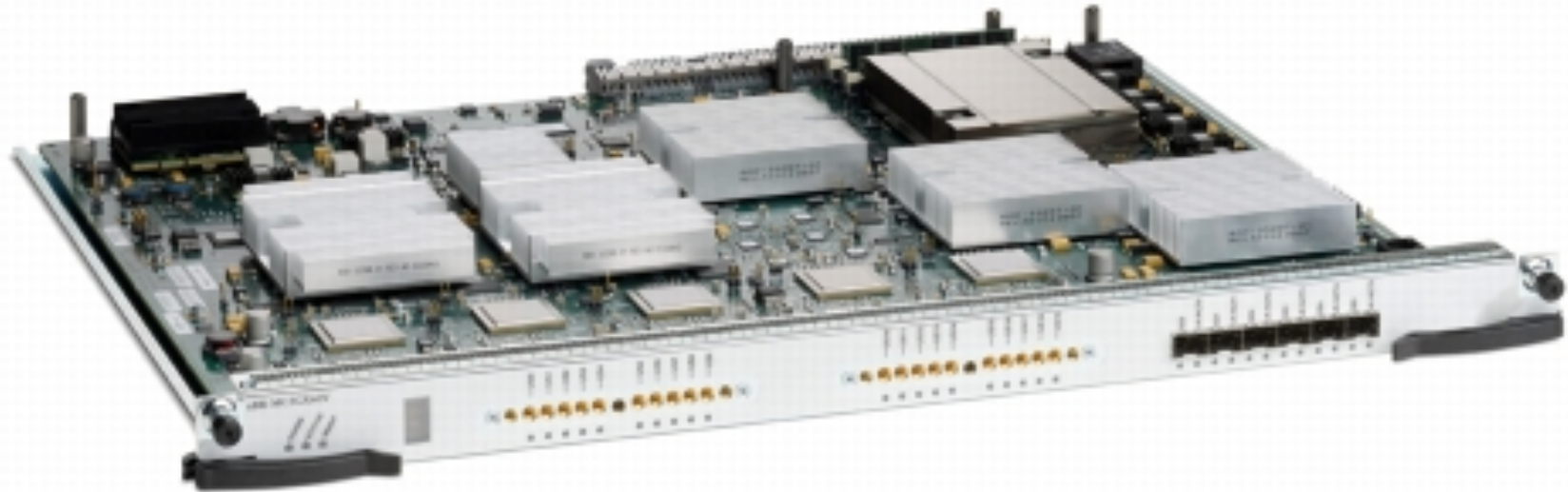

- The Cisco uBR-MC3GX60V cable interface line card has six Gigabit Ethernet (GE) interface ports organized into three pairs for DS connectivity. Each pair supports 1+1 redundancy
- The GE interfaces connect to an external Edge Quadrature Amplitude Modulation (EQAM) device.

uBR10012 Router Shared Port Adapters

- **SPA-24XDS-SFP: Cisco Wideband SPA**
 - The Cisco Wideband SPA is used for downstream data traffic only.
 - One ACTIVE and one PROTECT Gigabit Ethernet port.
 - Used to send traffic to the external edge QAM device.
 - M-CMTS
- **SPA-5X1GE-V2: 5-Port Gigabit Ethernet SPA**
- **SPA-1X10GE-L-V2: 1-Port 10-Gigabit Ethernet SPA**

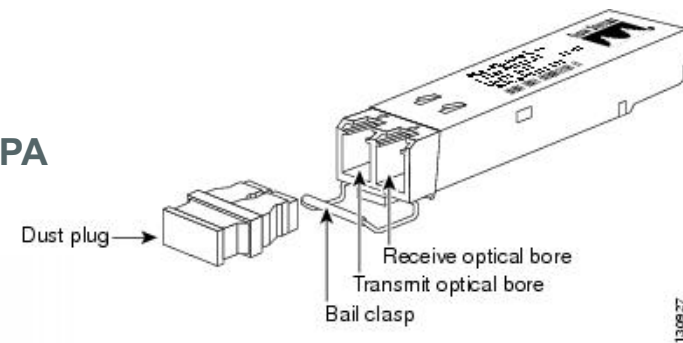



Basic Configuration and “show” commands

Downstream Frequency

Relevant Commands:

```
show controller cable <X/Y/Z> downstream
show controller cable <X/Y/Z>
show running interface cable <X/Y/Z>
```

```
CMTS# show run interface cable 8/0/0
```

```
interface Cable8/0/0
  cable downstream annex B
  cable downstream modulation 256qam
  cable downstream interleave-depth 32
  cable downstream frequency 687000000
  cable downstream channel-id 0
  cable downstream rf-shutdown
```

- Most Cable Line Cards (CLC) now have a built-in upconverter. Exceptions are the older cards such as MC16C and MC28C.
- DS ports frequency range: 55-999 MHz (varies by linecard)

```
CMTS# show controllers cable 8/0/0 downstream
```

```
Cable8/0/0 Downstream is up
  Frequency 687.0000 MHz, Channel Width 6 MHz, 256-QAM, Symbol Rate
5.360537 Msps
```

```
FEC ITU-T J.83 Annex B, R/S Interleave I=32, J=4
Downstream channel ID: 0
```

```
CMTS#show controllers cable 8/0/0 | begin Upconverter
```

```
Upconverter: vcom
```

```
Cable8/0/0 Upconverter is Enabled Output is Enabled
```

```
Model: 74-3153-02 Serial Number: 0WAV084000UV CLEI Code: FFFFFFFF
```

```
HW Rev: PC2D0109 SW Rev: 203, NVRAM Rev: 021 ECI number FFFFFF
```

```
Downstream Frequency 687.0000 MHz
```

```
RF Power 61.0 dB
```

Downstream Modulation

Relevant Commands:

```
show controller cable <X/Y/Z> downstream
show controller cable <X/Y/Z>
show running interface cable <X/Y/Z>
```

```
CMTS# show run interface cable 8/0/0
```

```
interface Cable8/0/0
  cable downstream annex B
  cable downstream modulation 256qam
  cable downstream interleave-depth 32
  cable downstream frequency 687000000
  cable downstream channel-id 0
  cable downstream rf-shutdown
```

- The downstream modulation should be set. Many MSO's, especially if they support digital cable, now operate at 256 QAM.

```
CMTS# show controllers cable 8/0/0 downstream
```

```
Cable8/0/0 Downstream is up
  Frequency 687.0000 MHz, Channel Width 6 MHz, 256-QAM, Symbol Rate 5.360537 Msps
  FEC ITU-T J.83 Annex B, R/S Interleave I=32, J=4
  Downstream channel ID: 0
```

```
CMTS# show controllers cable 8/0/0 | begin Upconverter
```

```
Upconverter: vcom
Cable8/0/0 Upconverter is Enabled Output is Enabled
  Model: 74-3153-02 Serial Number: 0WAV084000UV CLEI Code: FFFFFFFF
  HW Rev: PC2D0109 SW Rev: 203, NVRAM Rev: 021 ECI number FFFFFF
  Downstream Frequency 687.0000 MHz
  RF Power 61.0 dB
```

Downstream Port Enable

Relevant Commands:

```
show controller cable <X/Y/Z> downstream  
show running interface cable <X/Y/Z>
```

```
CMTS# show run interface cable 8/0/0
```

```
interface Cable8/0/0  
  cable downstream annex B  
  cable downstream modulation 256qam  
  cable downstream interleave-depth 32  
  cable downstream frequency 687000000  
  cable downstream channel-id 0  
  no cable downstream rf-shutdown  
  cable downstream rf-power 61
```

- The default downstream configuration has RF output disabled. Enable this explicitly.

```
CMTS# show controllers cable 8/0/0 | begin Upconverter
```

```
Upconverter: vcom  
Cable8/0/0 Upconverter is Disabled Output is Disabled  
Model: 74-3153-02 Serial Number: 0WAV084000UV CLEI Code: FFFFFFFF  
HW Rev: PC2D0109 SW Rev: 203, NVRAM Rev: 021 ECI number FFFFFF  
Downstream Frequency 687.0000 MHz  
RF Power Disabled
```

Downstream Port Enable (cont.)

Relevant Commands:

```
show controller cable <X/Y/Z>  
show running interface cable <X/Y/Z>
```

```
CMTS# conf t  
Enter configuration commands, one per line. End with CNTL/Z.  
CMTS(config)# int c8/0/0  
CMTS(config-if)# no cable downstream rf-shutdown  
CMTS(config-if)#  
SLOT 8/0: Apr 1 16:36:41.102 UTC: %UPCONV-5-UPDOWN: interface Cable8/0/0  
upconverter output changed to Up  
CMTS(config-if)# ^Z  
CMTS# show controllers cable 8/0/0 | begin Upconverter  
Upconverter: vcom  
Cable8/0/0 Upconverter is Enabled Output is Enabled  
Model: 74-3153-02 Serial Number: 0WAV084000UV CLEI Code: FFFFFFFF  
HW Rev: PC2D0109 SW Rev: 203, NVRAM Rev: 021 ECI number FFFFFF  
Downstream Frequency 687.0000 MHz  
RF Power 55.0 dB
```

Downstream RF power output

Relevant Commands:

```
show controller cable <X/Y/Z>  
show running interface cable <X/Y/Z>
```

```
CMTS# show run interface cable 8/0/0
```

```
interface Cable8/0/0  
  cable downstream annex B  
  cable downstream modulation 256qam  
  cable downstream interleave-depth 32  
  cable downstream frequency 687000000  
  cable downstream channel-id 0  
  cable downstream rf-shutdown  
  cable downstream rf-power 61
```

- With the exception of older legacy cards, CLC's produce RF output which should be set according to a plant's power budget.
- Note some CLC's only produce IF output and need an external upconverter.

```
CMTS# show controllers cable 8/0/0 | begin Upconverter
```

```
Upconverter: vcom  
Cable8/0/0 Upconverter is Enabled Output is Enabled  
Model: 74-3153-02 Serial Number: 0WAV084000UV CLEI Code: FFFFFFFF  
HW Rev: PC2D0109 SW Rev: 203, NVRAM Rev: 021 ECI number FFFFFF  
Downstream Frequency 687.0000 MHz  
RF Power 61.0 dB
```

Upstream Frequency

Relevant Commands:

```
show controller cable <X/Y/Z> upstream <W>  
show running interface cable <X/Y/Z>
```

```
CMTS# show run interface cable 8/0/0  
  
interface Cable8/0/0  
  cable upstream 0 frequency 24000000  
  cable upstream 0 channel-width 3200000 3200000  
  cable upstream 0 minislot-size 4  
  cable upstream 0 modulation-profile 21  
  cable upstream 0 shutdown
```

- US ports frequency range: 5-85 MHz (varies by linecard)

```
CMTS1# show controller cable 8/0/0 upstream 0  
Cable8/0/0 Upstream 0 is administratively down  
  Frequency 24.000 MHz, Channel Width 3.200 MHz, 64-QAM Symbol Rate 2.560 Msps  
  This upstream is mapped to physical port 0  
  Spectrum Group is overridden  
  MER(SNR) - Unknown - no modems online.  
  Nominal Input Power Level 1 dBmV, Tx Timing Offset 0  
  Ranging Backoff Start 3, Ranging Backoff End 6  
  Ranging Insertion Interval automatic (60 ms)
```

Upstream Channel Width

Relevant Commands:

```
show controller cable <X/Y/Z> upstream <W>
show running interface cable <X/Y/Z>
```

```
CMTS# show run interface cable 8/0/0
```

```
interface Cable8/0/0
  cable upstream 0 frequency 24000000
  cable upstream 0 channel-width 3200000 3200000
  cable upstream 0 minislot-size 4
  cable upstream 0 modulation-profile 21
  cable upstream 0 shutdown
```

- Set the channel width.
- Note that the CMTS will allow frequencies to overlap, so ensure that there is adequate separation between frequency bands.
- The example below shows a channel width of 3.2MHz.

```
CMTS1# show controller cable 8/0/0 upstream 0
```

```
Cable8/0/0 Upstream 0 is administratively down
  Frequency 24.000 MHz, Channel Width 3.200 MHz, 64-QAM Symbol Rate 2.560 Msps
  This upstream is mapped to physical port 0
  Spectrum Group is overridden
  MER(SNR) - Unknown - no modems online.
  Nominal Input Power Level 1 dBmV, Tx Timing Offset 0
  Ranging Backoff Start 3, Ranging Backoff End 6
  Ranging Insertion Interval automatic (60 ms)
```

Upstream Port Enable

```
interface Cable8/0/0
  cable upstream 0 frequency 24000000
  cable upstream 0 channel-width 3200000 3200000
  cable upstream 0 minislot-size 4
  cable upstream 0 modulation-profile 21
  no cable upstream 0 shutdown
```

Relevant Commands:

```
show controller cable <X/Y/Z> upstream <W>
show running interface cable <X/Y/Z>
```

- The default upstream configuration has the port shutdown.
- Enable this explicitly.

```
CMTS1# show controller cable 8/0/0 upstream 0
Cable8/0/0 Upstream 0 is administratively down
  Frequency 24.000 MHz, Channel Width 3.200 MHz, 64-QAM Symbol Rate 2.560 Msps
  This upstream is mapped to physical port 0
  Spectrum Group is overridden

CMTS1# conf term
Enter configuration commands, one per line.  End with CNTL/Z.
CMTS1(config)# int c8/0/0
CMTS(config-if)# no cable upstream 0 shutdown
523869: *Apr  1 16:51:00.545 UTC: %UBR10000-5-UPDOWN: Interface Cable8/0/0 U0, changed
state to up
523870: *Apr  1 16:51:00.545 UTC: %ALARM-6-ENTITY_INFO: CLEAR INFO Cable8/0-US0 Physical
Port Administrative State Down
523871: *Apr  1 16:51:00.545 UTC: %SNMP-5-LINK_UP: LinkUp:Interface Cable8/0/0-upstream0
changed state to up
CMTS(config-if)# ^Z
CMTS1# show controller cable 8/0/0 upstream 0
Cable8/0/0 Upstream 0 is up
  Frequency 24.000 MHz, Channel Width 3.200 MHz, 64-QAM Symbol Rate 2.560 Msps
  This upstream is mapped to physical port 0
  Spectrum Group is overridden
  US phy MER(SNR)_estimate for good packets - 34.398 dB
```

Cable Modems

Relevant Commands:

```
show cable modem <mac>
show cable modem <mac> verbose
show cable modem <mac> cpe
show cable modem summary total
```

```
CMTS1# show cable modem 0023.a279.1d7c
```

MAC Address	IP Address	I/F	MAC State	Prim Sid	RxPwr (dBmv)	Timing Offset	Num CPE	I P
0023.a279.1d7c	10.1.1.2	C7/1/0/U0	online (pt)	6	-0.50	1441	0	D N

```
CMTS1#show cable modem summary total
```

Interface	Cable Modem						Description			
	Total	Reg	Oper	Unreg	Offline	Wideband	initRC	initD	initIO	initO
C6/0/0/U0	3	3	3	0	0	1	0	0	0	0
C6/0/0/U1	1	1	1	0	0	0	0	0	0	0
C7/1/0/U0	4	4	4	0	0	3	0	0	0	0
Total:	8	8	8	0	0	4	0	0	0	0

show version

Relevant Commands:

```
show version
show running-config
show startup-config
show diag
```

```
CMTS1# show version
```

```
Cisco IOS Software, 10000 Software (UBR10K4-K9P6U2-M), Version 12.2(33)SCF1, RELEASE SOFTWARE (fc1)
```

```
Technical Support: http://www.cisco.com/techsupport
```

```
Copyright (c) 1986-2011 by Cisco Systems, Inc.
```

```
Compiled Fri 30-Sep-11 18:16 by prod_rel_team
```

```
ROM: System Bootstrap, Version 12.2(20071113:194412) [shalpin-rom-1_2 101], DEVELOPMENT SOFTWARE
```

```
CMTS1 uptime is 3 days, 15 hours, 12 minutes
```

```
Uptime for this control processor is 3 days, 15 hours, 12 minutes
```

```
System returned to ROM by reload at 07:52:34 UTC Thu Apr 5 2012
```

```
System image file is "disk0:ubr10k4-k9p6u2-mz.122-33.SCF1.bin"
```

```
Last reload type: Normal Reload
```

```
Last reload reason: Reload command
```

show version (cont.)

Relevant Commands:

```
show running-config  
show startup-config  
show diag
```

```
Cisco uBR10000 (PRE4-RP) processor with 2588671K/163839K bytes of memory.
```

```
Processor board ID SPE10280C6C
```

```
SB-1 CPU at 800Mhz, Implementation 0x410, Rev 5.0, 512KB L2 Cache
```

```
Backplane version 1.1, 8 slot
```

```
Last reset from software reset
```

```
PXF processor tmc0 is running.
```

```
PXF processor tmc1 is running.
```

```
PXF processor tmc2 is running.
```

```
PXF processor tmc3 is running.
```

```
2 DTCC card(s)
```

```
1 Jacket card(s): 2 SPA card(s)
```

```
1 FastEthernet interface
```

```
40 Cable Modem interfaces
```

```
7039K bytes of non-volatile configuration memory.
```

```
125184K bytes of ATA compact flash in bootflash (Sector size 512 bytes).
```

```
990864K bytes of ATA compact flash in disk0 (Sector size 512 bytes).
```

```
Standby is up
```

```
Standby has 2752512K bytes of memory
```

```
Configuration register is 0x2102
```

Facility alarms

Relevant Commands:

```
show facility-alarm status
show logging
```

```
CMTS1# show facility-alarm status
```

```
Thresholds:
```

```
Intake minor 41 major 51 critical 73
```

```
Outlet minor 48 major 58 critical 85
```

```
System Totals Critical: 1 Major: 0 Minor: 0
```

Source	Severity	ACO	Description [Index]
-----	-----	---	-----
slot 4/0 [4]	INFO	NORMAL	Unsupported card type OIR Alarm - subslot 0
SFP container 1/0/0	CRITICAL	NORMAL	SFP Missing Alarm [0]
Cable5/0-US2	INFO	NORMAL	Physical Port Administrative State Down [1]
Cable5/0-US3	INFO	NORMAL	Physical Port Administrative State Down [1]
Cable5/0-US4	INFO	NORMAL	Physical Port Administrative State Down [1]

Inventory

Relevant Commands:

```
show inventory  
show diag
```

```
CMTS1# show inventory  
NAME: "Chassis", DESCR: "uBR10000 chassis"  
PID: UBR10012          , VID:      , SN: SPE10280C6C  
  
NAME: "RP A", DESCR: "Performance Routing Engine"  
PID: ESR-PRE4         , VID: V01 , SN: CAT1203F0AB  
  
NAME: "SPA bay 1/0", DESCR: "WIDEBAND DOCSIS SPA"  
PID: SPA-24XDS-SFP    , VID: V01, SN: CAT10385B64  
  
NAME: "module 5/1", DESCR: "MC520U_D_connector"  
PID: UBR10-MC5X20U-D  , VID: V02 , SN: CAT111958UZ  
  
NAME: "module 6/0", DESCR: "MC20X20 I-CMTS 20DSX20US CLC"  
PID: UBR-MC20X20V     , VID: V01 , SN: CAT1339E06Q  
  
NAME: "module 7/0", DESCR: "MC20X20 I-CMTS 20DSX20US CLC"  
PID: UBR-MC20X20V     , VID: V01 , SN: CAT1340E01Q  
  
NAME: "module 7/1", DESCR: "MC3G60 M-CMTS 3GE 72DSX60US CLC"  
PID: UBR-MC3GX60V     , VID: V01 , SN: CAT1441E125
```



DOCSIS 3.0 Channel Bonding

DOCSIS 3.0 I-CMTS vs.. M-CMTS

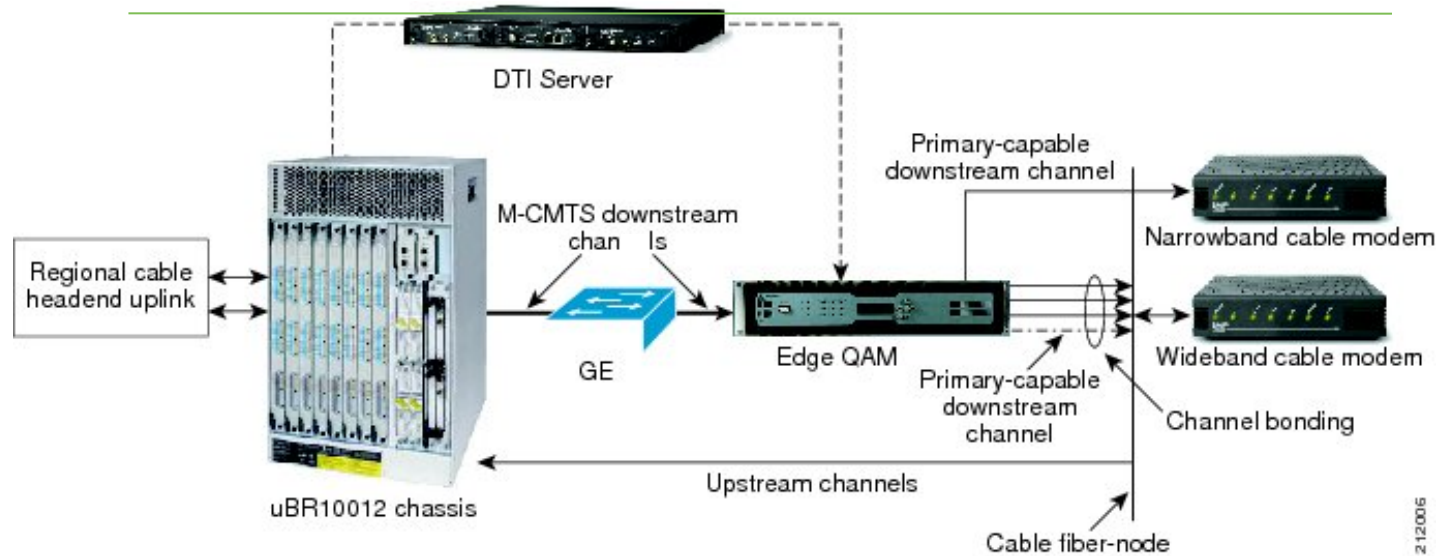
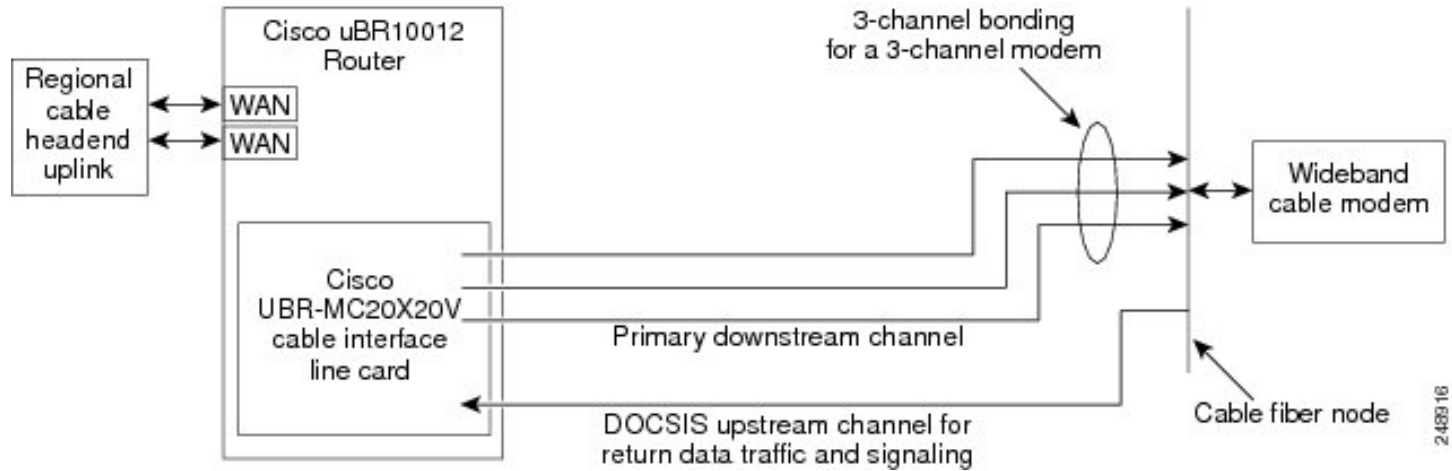

Polling Question 2

Which diagram from the previous slide depicts an I-CMTS configuration?

- a) TOP
- b) BOTTOM

DOCSIS 3.0 Channel Bonding Overview

- New features have been added to the DOCSIS specs in order to address the demand for increased bandwidth.
- With DOCSIS 3.0, the ability for Cable Modems to transmit and receive across multiple channels is introduced.
- These concepts are known as Downstream Channel Bonding and Upstream Channel Bonding.
- From the CMTS perspective, there are 5 main components that need to be configured for Downstream Channel Bonding:
 1. Controller
 2. Interface Cable
 3. Integrated-Cable
 4. Wideband-Cable
 5. Fiber-node

Controller

Relevant Commands:

```
show controllers integrated-cable 7/0/0 counters rf-channel  
show controllers integrated-cable 7/0/0 config
```

```
!  
controller Integrated-Cable 7/0/0  
  rf-channel 0 cable downstream channel-id 97  
  rf-channel 0 frequency 681000000 annex B modulation 256qam interleave 32  
  rf-channel 0 rf-power 52.0  
  no rf-channel 0 rf-shutdown  
  rf-channel 1 cable downstream channel-id 98  
  rf-channel 1 frequency 687000000 annex B modulation 256qam interleave 32  
  rf-channel 1 rf-power 52.0  
  no rf-channel 1 rf-shutdown  
  rf-channel 2 cable downstream channel-id 99  
  rf-channel 2 frequency 693000000 annex B modulation 256qam interleave 32  
  rf-channel 2 rf-power 52.0  
  no rf-channel 2 rf-shutdown  
  rf-channel 3 cable downstream channel-id 100  
  rf-channel 3 frequency 699000000 annex B modulation 256qam interleave 32  
  rf-channel 3 rf-power 52.0  
  no rf-channel 3 rf-shutdown  
!
```

Retain the system-generated default channel ID's

```
CMTS1# show controller integrated-cable 7/0/0 counters rf-channel
```

Controller	RF Chan	MPEG Packets Tx	MPEG bps	MPEG Mbps	Sync Packets Tx	MAP Queue Packets Tx
7/0/0	0	5406341508	29337376	29.743	1105170888	20849541696
7/0/0	1	5352261326	29280123	29.280	1105170887	20849541695
7/0/0	2	5352239729	29274528	29.274	1105170887	20849541695
7/0/0	3	5352276150	29251244	29.251	1105170887	20849541695

Interface

Relevant Commands:

```
show cable mac-domain cable 7/0/0 cgd-associations
show cable fiber-node
```

```
interface Cable7/0/0
  downstream Integrated-Cable 7/0/0 rf-channel 0-3 upstream 0-3
  cable default-phy-burst 0
  cable bundle 1
  cable upstream max-ports 4
  cable upstream 0 connector 0
  cable upstream 0 frequency 24200000
  cable upstream 0 channel-width 3200000 3200000
  cable upstream 0 power-level 4
  cable upstream 0 docsis-mode atdma
  cable upstream 0 minislot-size 2
  cable upstream 0 power-adjust continue 10
  cable upstream 0 range-backoff 3 6
  cable upstream 0 modulation-profile 221
  cable upstream 0 attribute-mask 20000000
  no cable upstream 0 shutdown
  cable upstream 1 connector 0
  cable upstream 1 frequency 29100000
  cable upstream 1 channel-width 3200000 3200000
  cable upstream 1 docsis-mode tdma
  cable upstream 1 minislot-size 2
  cable upstream 1 power-adjust continue 10
  cable upstream 1 range-backoff 3 6
<snip>
```

Define Primary Channels

```
CMTS1# show cable mac-domain cable 7/0/0 cgd-associations
```

CGD Host	Resource	DS Channels	Upstreams (AllUS)	Active Remote DS
Ca7/0/0	7/0/0	0-3	0-3	0-3

Integrated-Cable

Relevant Commands:

```
show controllers integrated-Cable 7/0/0 mapping rf-channel
```

```
show controllers integrated-Cable 7/0/0 mapping wb-channel
```

```
!  
interface Integrated-Cable7/0/0:0  
  cable bundle 1  
  cable rf-bandwidth-percent 50  
!  
interface Integrated-Cable7/0/0:1  
  cable bundle 1  
  cable rf-bandwidth-percent 50  
!  
interface Integrated-Cable7/0/0:2  
  cable bundle 1  
  cable rf-bandwidth-percent 50  
!  
interface Integrated-Cable7/0/0:3  
  cable bundle 1  
  cable rf-bandwidth-percent 50  
!
```

Define static bandwidth allocation of a downstream RF channel.

The default is 0

Cable Bundle is inherited from Mac Domain. It is not configurable.

```
CMTS1# show controllers integrated-Cable 7/0/0 mapping rf-channel
```

Ctrlr	RF channel	MC BW %	MC Rem. Ratio	WB channel	WB BW %	WB Rem. Ratio
7/0/0	0	50	1	7/0/0:0	46	1
7/0/0	1	50	1	7/0/0:0	46	1
7/0/0	2	50	1	7/0/0:0	46	1
7/0/0	3	50	1	7/0/0:0	46	1

Wideband

Relevant Commands:

```
show controllers integrated-Cable 7/0/0 mapping wb-channel  
show controllers integrated-Cable 7/0/0 mapping rf-channel
```

```
!  
interface Wideband-Cable7/0/0:0  
  cable bundle 1  
  cable rf-channel 0 bandwidth-percent 46  
  cable rf-channel 1 bandwidth-percent 46  
  cable rf-channel 2 bandwidth-percent 46  
  cable rf-channel 3 bandwidth-percent 46
```

The percent of bandwidth from this RF channel that will be used for the wideband interface.

The default is 100%

```
CMTS1# show controllers integrated-Cable 7/0/0 mapping wb-channel
```

Ctrlr	WB channel	RF channel	BW %	Remaining Ratio
7/0/0	0	7/0/0:0	46	1
		7/0/0:1	46	1
		7/0/0:2	46	1
		7/0/0:3	46	1

```
CMTS1# show controllers integrated-Cable 7/0/0 mapping rf-channel
```

Ctrlr	RF channel	MC BW %	MC Rem. Ratio	WB channel	WB BW %	WB Rem. Ratio
7/0/0	0	50	1	7/0/0:0	46	1
7/0/0	1	50	1	7/0/0:0	46	1
7/0/0	2	50	1	7/0/0:0	46	1
7/0/0	3	50	1	7/0/0:0	46	1

Fiber-Node

Relevant Commands:

```
show cable fiber-node
```

```
show cable mac-domain cable 7/0/0 downstream-service-group
```

```
!  
cable fiber-node 1  
  downstream Integrated-Cable 7/0/0 rf-channel 0-3  
  upstream Cable 7/0 connector 0-3
```

```
CMTS1# show cable fiber-node
```

```
-----  
  
Fiber-Node 1  
Channel(s) : downstream Integrated-Cable 7/0/0: 0-3  
Channel ID(s): 97, 98, 99, 100  
upstream Cable 7/0: 0 2  
  FN Config Status: Configured (status flags = 0x01)  
  MDD Status: Valid
```

```
CMTS1# show cable mac-domain cable 7/0/0 downstream-service-group
```

Cable	MD-DS-SG	Resource	RF Chan	Primary Chan
IF	Id			
C7/0/0	1	7/0/0	00-03	0 1 2 3

```
CMTS1# show cable mac-domain cable 7/0/0 upstream-service-group
```

```
Cable MD 7/0/0  
  US-SG-ID : 2          US-Chan : U0,1,2,3  
  Primary-DS: 7/0/0:0  US-SG-ID: 2  
  MDD US-List : U0,1,2,3  
  MDD Ambiguity : U0,1,2,3
```

Fiber-Node Invalid

Relevant Commands:

```
show cable fiber-node  
show cable cgd-associations
```

```
!  
interface Wideband-Cable7/0/0:0  
  cable bundle 99  
  cable rf-channel 0 bandwidth-percent 46  
  cable rf-channel 1 bandwidth-percent 46  
  cable rf-channel 2 bandwidth-percent 46  
  cable rf-channel 3 bandwidth-percent 46
```

```
!  
interface Cable7/0/0  
  downstream Integrated-Cable 7/0/0 rf-channel 0-3 upstream 0-3  
  no cable packet-cache  
  cable default-phy-burst 0  
  cable map-advance dynamic 600 1000  
  cable bundle 1
```

```
CMTS1# show cable fiber-node 1  
-----  
  
Fiber-Node 1  
Channel(s) : downstream Integrated-Cable 7/0/0: 0-3  
Channel ID(s): 97, 98, 99, 100  
upstream Cable 7/0: 0-3  
  FN Config Status: Configured (status flags = 0x09)  
  MDD Status: Invalid  
  Bundle ID Inconsistent
```

MDD: MAC Domain Descriptor

```
CMTS1# show controller c7/0/0 | beg DS_chan_id
```

```
DS_chan_id  RFID  Interface
```

```
-----  
97          720   In7/0/0:0  
98          721   In7/0/0:1  
99          722   In7/0/0:2  
100         723   In7/0/0:3  
-----
```

```
MDDs          Primary          Non-Primary
```

```
-----  
7/0/0:0      9              0  
7/0/0:1      9              0  
7/0/0:2      9              0  
7/0/0:3      9              0  
-----
```

```
CMTS1# show controller c7/0/0 | beg DS_chan_id
```

```
DS_chan_id  RFID  Interface
```

```
-----  
97          720   In7/0/0:0  
98          721   In7/0/0:1  
99          722   In7/0/0:2  
100         723   In7/0/0:3  
-----
```

```
MDDs          Primary          Non-Primary
```

```
-----  
7/0/0:0      23             0  
7/0/0:1      23             0  
7/0/0:2      23             0  
7/0/0:3      23             0  
-----
```

Debugs to verify MDD generation on CMTS

- debug cable interface cable x/y/z verbose
- debug cable mdd

```
MDD MESSAGE
```

```
FRAME HEADER
```

```
<snip>
```

```
MDD TLV
```

```
Downstream Active Channel List
```

```
Channel ID:          97  
Frequency:           681000000Hz  
Modulation Order/Annex: 256 QAM/Annex B  
Primary Capable:     Primary-Capable
```

```
<snip>
```

```
MAC Domain Downstream Service Group
```

```
MD-DS-SG ID:        1
```

```
Channel IDs:         97  
                    98  
                    99  
                    100
```

```
Downstream Ambiguity Resolution Frequency List
```

```
Frequencies:        681000000Hz  
                    687000000Hz  
                    693000000Hz  
                    699000000Hz
```

Ranging and Registration

Debugs for Ranging and Registration

- debug cable mac-address <MAC> verbose
- debug cable mdd
- debug cable range
- debug cable registration
- debug cable tlv
- debug cable dhcp
- debug cable service-ds-selection

```
Sep  4 01:14:03.891: Bonding Initial Ranging request from 38c8.5cb6.63e8, SID 0 [16383] on Interface
Cable7/0/0/U1: MD-DS-SG-ID 1, Cap flags 192Src sap 85
Sep  4 01:14:03.891: Initial Ranging: Downstream channel ID is 98 (CGD host DS chan Id 0)
Sep  4 01:14:03.891: CM mac address found. Assigned Primary SID 3.
Sep  4 01:14:03.891: cmts_tcc_uschan_add: CM 38c8.5cb6.63e8 tcs 0 chan 1 tech 2 ref 0
Sep  4 01:14:03.895: Modem 38c8.5cb6.63e8: Host Ca7/0/0/U1: ds_channel_id 98, rfid 721
Sep  4 01:14:03.895: CM Ambiguity Resolution Done SG_ID=1
Sep  4 01:14:03.895: Timing error 1038, power error -6.00dB, freq error -12(thres 1280 adj 0) [sm per
20.0 sec]
Sep  4 01:14:03.095:      0x0120: 03 04 09 01 00 0C 01 01 0F 02 00 08
Sep  4 01:14:03.895: Ca7/0/0/U1: Send RNG-RSP (1) for 38c8.5cb6.63e8, SID 3, DS RFID 721
Sep  4 01:14:04.891: Ranging CM 38c8.5cb6.63e8, SID 3 iuc 4 mslot 13 on I/f Cable7/0/0/U1
Sep  4 01:14:04.891: 38c8.5cb6.63e8: dyn pwr status 0 tx lvl 85 ch load 255 min load 0
Sep  4 01:14:04.891: Ranging request from 38c8.5cb6.63e8, SID 5 [5/98/721] on Interface Cable7/0/0/U1
Sep  4 01:14:04.891: Timing error 0, power error -6.00dB, freq error -17(thres 1280 adj 0) [sm per
20.0 sec]
Sep  4 01:14:04.891: Ranging successful.
```

DOCSIS 3.0 Registration Diagram

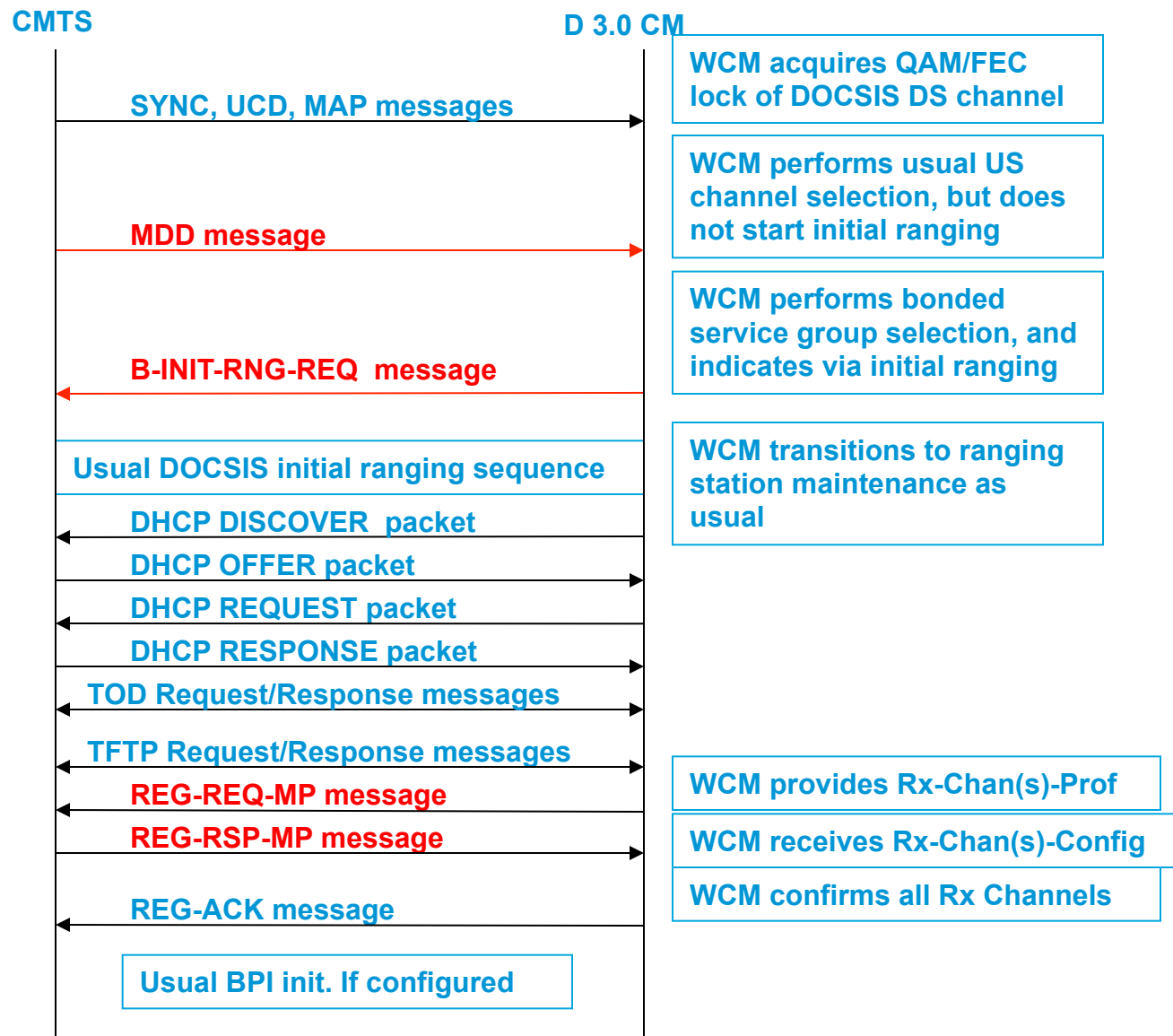

Modems w-online

Relevant Commands:

```
show cable modem wideband
show cable modem primary-channel wideband
show cable modem <MAC> verbose
show cable modem <MAC> wideband rcs-status
```

CMTS1# show cable modem wideband

MAC Address	IP Address	I/F	MAC State	Prim Sid	RCC ID	MD-DS-SG/ MD-US-SG
4844.878d.27bc	10.1.1.2	C7/0/0/U1	w-online	1	1	1 / N/A
38c8.5cb6.6376	10.1.1.3	C7/0/0/U1	w-online	2	1	1 / N/A
38c8.5cb6.63e8	10.1.1.4	C7/0/0/U1	w-online	3	1	1 / N/A

CMTS1# show cable modem primary-channel wideband

MAC Address	IP Address	Host Interface	MAC State	Prim Sid	Num CPE	Primary Downstream	DS RfId
4844.878d.27bc	10.1.1.2	C7/0/0/U1	w-online	1	1	In7/0/0:0	720
38c8.5cb6.6376	10.1.1.3	C7/0/0/U1	w-online	2	0	In7/0/0:2	722
38c8.5cb6.63e8	10.1.1.4	C7/0/0/U1	w-online	3	0	In7/0/0:1	721

Modems w-online (cont.)

```
CMTS1# sh cable mod 38c8.5cb6.63e8 wide rcs-status
CM : 38c8.5cb6.63e8
RF : 7/0/0 0
  Status : UP
  FEC/QAM Failure : 0
  Dup FEC/QAM Failure : 0
  FEC/QAM Recovery : 0
  Dup FEC/QAM Recovery : 0
  MDD Failure : 0
  Dup MDD Failure : 0
  MDD Recovery : 0
  Dup MDD Recovery : 0
  Flaps : 0
  Flap Duration : 00:00
RF : 7/0/0 2
  Status : UP
  FEC/QAM Failure : 0
  Dup FEC/QAM Failure : 0
  FEC/QAM Recovery : 0
  Dup FEC/QAM Recovery : 0
  MDD Failure : 0
  Dup MDD Failure : 0
  MDD Recovery : 0
  Dup MDD Recovery : 0
  Flaps : 0
  Flap Duration : 00:00
RF : 7/0/0 3
  Status : UP
  FEC/QAM Failure : 0
  Dup FEC/QAM Failure : 0
  FEC/QAM Recovery : 0
  Dup FEC/QAM Recovery : 0
  MDD Failure : 0
  Dup MDD Failure : 0
  MDD Recovery : 0
  Dup MDD Recovery : 0
  Flaps : 0
  Flap Duration : 00:00
```

Relevant Commands:

```
show cable modem wideband
show cable modem <mac> wideband rcs-status
show cable modem <MAC> verbose
show cable modem primary-channel wideband
```

```
CMTS1# show cable modem 38c8.5cb6.63e8 verbose
MAC Address : 38c8.5cb6.63e8
IP Address : 10.1.1.4
IPv6 Address : ---
Dual IP : N
Prim Sid : 3
Host Interface : C7/0/0/U1
MD-DS-SG / MD-US-SG : 1 / N/A
MD-CM-SG : 0x3C0101
Primary Wideband Channel ID : 897 (Wi7/0/0:0)
Primary Downstream : In7/0/0:1 (RfId : 721)
Wideband Capable : Y
RCP Index : 3
RCP ID : 00 10 00 00 04
Multi-Transmit Channel Mode : N
Upstream Channel : US1
Ranging Status : sta
<snip>
MAC Version : DOC3.0
QoS Provisioned Mode : DOC1.1
```

Polling Question 3

What Cable topics would you like to learn more in the future?

- a) Packetcable
- b) Basic CMTS configuration and troubleshooting.
- c) DOCSIS Set-Top Gateway (DSG, ADSG)
- d) DOCSIS Load Balancing
- e) DOCSIS 3.0

Submit Your Questions Now!

Use the Q&A panel to submit your questions. Experts will start responding those



References

- SP Video Support community – You can ask your questions here <https://supportforums.cisco.com/community/netpro/service-providers/video>
- Support pages:
 - http://www.cisco.com/en/US/products/hw/cable/ps2209/products_data_sheets_list.html
 - http://www.cisco.com/en/US/products/hw/cable/ps2217/tsd_products_support_series_home.html
 - http://www.cisco.com/en/US/products/hw/cable/ps2209/prod_installation_guides_list.html
 - http://www.cisco.com/en/US/products/hw/cable/ps2217/prod_installation_guides_list.htm
 - http://www.cisco.com/en/US/docs/ios/cable/configuration/guide/ubr_ds_bonding_support_TSD_Island_of_Content_Chapter.html
- Other References
 - <http://www.cablelabs.com/cablemodem/specifications/index.html>

Q & A

Expert responding some of your questions verbally. Use the Q&A panel to continue asking your questions



Trivia Question

What cable/video milestone is celebrating its 10th anniversary at Cisco?

- a) Cisco Systems announces first cable modem for small office, home office and telecommuting environments.
- b) Winner of the Pioneer Technology Award for Data-Over-Cable System Interface Specification (DOCSIS).
- c) Cisco ships its 250,000th upstream cable modem termination system port (CMTS).

We Appreciate Your Feedback!

Those who fill out the Evaluation Survey will enter a raffle to win:

\$50 Amazon Gift Card

To complete the evaluation, please click on link provided in the chat or in the pop-up once the event is closed.

Ask The Experts Event (with Eric)

If you have additional questions, you can ask them to Eric. He will be answering from day September 12 to September 21st.

<https://supportforums.cisco.com/thread/2170514>

You can watch the video or read the Q&A 5 business days after the event at

<https://supportforums.cisco.com/community/netpro/ask-the-expert/webcasts>



Expert Series Webcast - Polish

Topic: How to Troubleshoot Cisco IOS Software



**Tuesday September 18th , at
10:00 a.m. Warsaw Time (CEST)**

Join Cisco Expert:

Andrzej Szczepanik

During the live event you will learn how to troubleshoot and prevent crashes on Cisco IOS Software devices with Cisco expert Andrzej Szczepanik. He will show how to resolve common issues and provide details on what information needs to be collected in case you need to contact the Technical Assistance Center (TAC) for further troubleshooting.

Register at

[http://tools.cisco.com/gems/cust/customerQA.do?
METHOD=E&LANGUAGE_ID=L&PRIORITY_CODE=4&SEMINAR_C
ODE=S17029](http://tools.cisco.com/gems/cust/customerQA.do?METHOD=E&LANGUAGE_ID=L&PRIORITY_CODE=4&SEMINAR_CODE=S17029)

Expert Series Webcast - Japanese

Topic: Nexus 7000 General Architecture and Troubleshooting

Monday September 24 at 10:00 a.m. JST (Tokyo)

Which is Tuesday September 25th at 6:00 PM PDT (San Francisco)

Join Cisco Expert:

Toshihiro Masumi

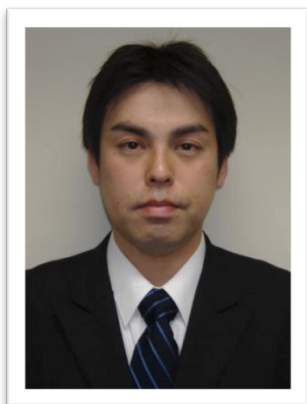

During the live event, Cisco subject matter expert Toshihiro Masumi will discuss several troubleshooting examples for Nexus 7000 after introducing its general architecture. There will be step-by-step troubleshooting presentation including demonstration using specific commands.

Register at

http://tools.cisco.com/gems/cust/customerQA.do?METHOD=E&LANGUAGE_ID=J&PRIORITY_CODE=4&SEMINAR_CODE=S16972

October Expert Series Webcast - English

Topic: Understanding and Troubleshooting ASA NAT

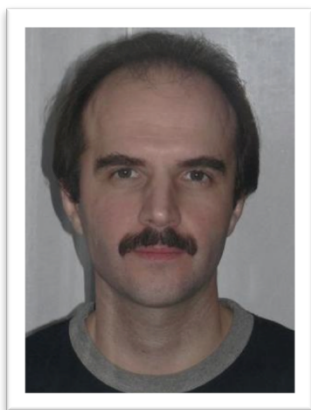

Tuesday October 2, at
12:00 p.m. Moscow
10:00 a.m. Brussels

Join Cisco Expert:

Oleg Tipisov

During the live event, Cisco subject matter expert Oleg Tipisov will focus on differences in NAT in versions of Cisco ASA software beginning from 8.3 and to latest versions. He will also highlight how to troubleshoot possible problems in NAT on Cisco ASA. The presentation will be based on specific examples from real service requests that was opened in Cisco TAC.

Register at

[http://tools.cisco.com/gems/cust/customerSite.do?
METHOD=E&LANGUAGE_ID=R&PRIORITY_CODE=4&SEMINAR_CODE
=S17057](http://tools.cisco.com/gems/cust/customerSite.do?METHOD=E&LANGUAGE_ID=R&PRIORITY_CODE=4&SEMINAR_CODE=S17057)

October Expert Series Webcast – English

Topic: Licensing Architecture: Cisco Unified Call Manager Version 9.x



**Tuesday October 9, at
11:30 a.m. India (IST)
5:00 p.m. Sydney
8:00 a.m Paris**

Join Cisco Expert:

Amit Singh

During the live event you will learn about the licensing architecture of Cisco Unified CallManager (CUCM) Version 9.x, how to prepare for the migration and information on the enterprise License Manager.

Registration for this live Webcast opens by September 12 @

<https://supportforums.cisco.com/community/netpro/expert-corner#view=webcasts>

October Expert Series Webcast - English

Topic: Troubleshooting SSL VPN on ASA

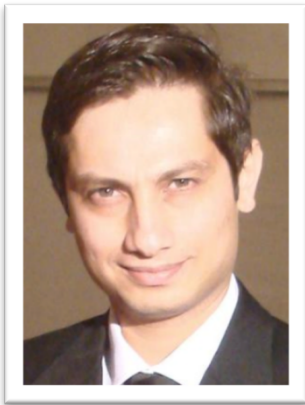

Tuesday October 30, at
8:00 a.m. Pacific Time
11:00 a.m. New York
4:00 p.m. Paris

Join Cisco Expert:

Jazib Frahim

During this live event you get expert knowledge on how to troubleshoot Secure Socket Layer- (SSL-) enabled SSL VPN on the Cisco Adaptive Security Appliances

Registration for this live Webcast opens by September 21st @

<https://supportforums.cisco.com/community/netpro/expert-corner#view=webcasts>

Ask the Expert Events – Current English



Topic: Concepts, Configuration and Troubleshooting Layer 2 MPLS VPN – Any Transport over MPLS (AToM)

Join Cisco Experts: **Vignesh R. P.**

Learn, ask and clarify any queries about about the Concept, Configuration and Troubleshooting Layer 2 MPLS VPN – Any Transport over MPLS (AToM).

Ends September 21



Topic: One Management with Prime Infrastructure 1.2

Join Cisco Experts: **Tejas Shah**

Get and update on the next generation converged wired, wireless, and assurance management solution

Ends September 21



Topic: Migration Best Practices for Adaptive Security Appliance 8.3/8.4

Join Cisco Experts: **Praveena Shanubhogue**

Learn and ask questions about migration best practices for Adaptive Security Appliance 8.3/8.4.

Ends September 19th

Join the discussion for these Ask The Expert Events at:

<https://supportforums.cisco.com/community/netpro/expert-corner#view=ask-the-experts>

We have communities in other languages

If you speak **Spanish, Portuguese, Japanese, Polish or Russian**, we invite you to ask your questions and collaborate in your language:

- Spanish → <https://supportforums.cisco.com/community/spanish>
- Portuguese → <https://supportforums.cisco.com/community/portuguese>
- Japanese → <https://supportforums.cisco.com/community/csc-japan>
- Polish → <https://supportforums.cisco.com/community/etc/netpro-polska>
- Russian → <https://supportforums.cisco.com/community/russian>

We invite you to actively collaborate in the Cisco Support Community and social media

<https://supportforms.cisco.com>



<http://www.facebook.com/CiscoSupportCommunity>



http://twitter.com/#!/cisco_support



<http://www.youtube.com/user/ciscosupportchannel>



<https://plus.google.com/110418616513822966153?prsrc=3#110418616513822966153/posts>



<http://itunes.apple.com/us/app/cisco-technical-support/id398104252?mt=8>



https://play.google.com/store/apps/details?id=com.cisco.swtg_android



<http://www.linkedin.com/groups/CSC-Cisco-Support-Community-3210019>



Newsletter Subscription: https://tools.cisco.com/gdrp/coiga/showsurvey.do?surveyCode=589&keyCode=146298_2&PHYSICAL%20FULFILLMENT%20Y/N=NO&SUBSCRIPTION%20CENTER=YES

Trivia Answer

What cable/video milestone is celebrating its 10th anniversary at Cisco?

- a) Cisco Systems announces first cable modem for small office, home office and telecommuting environments.
Cisco Achieved this in September 1998
- b) Winner of the Pioneer Technology Award for Data-Over-Cable System Interface Specification (DOCSIS).
Cisco Achieved this in 1999
- c) Cisco ships its 250,000th upstream cable modem termination system port (CMTS).
Cisco Achieved this in 2002.

Thank You for
Your Time

Please Take a Moment to Complete the Evaluation

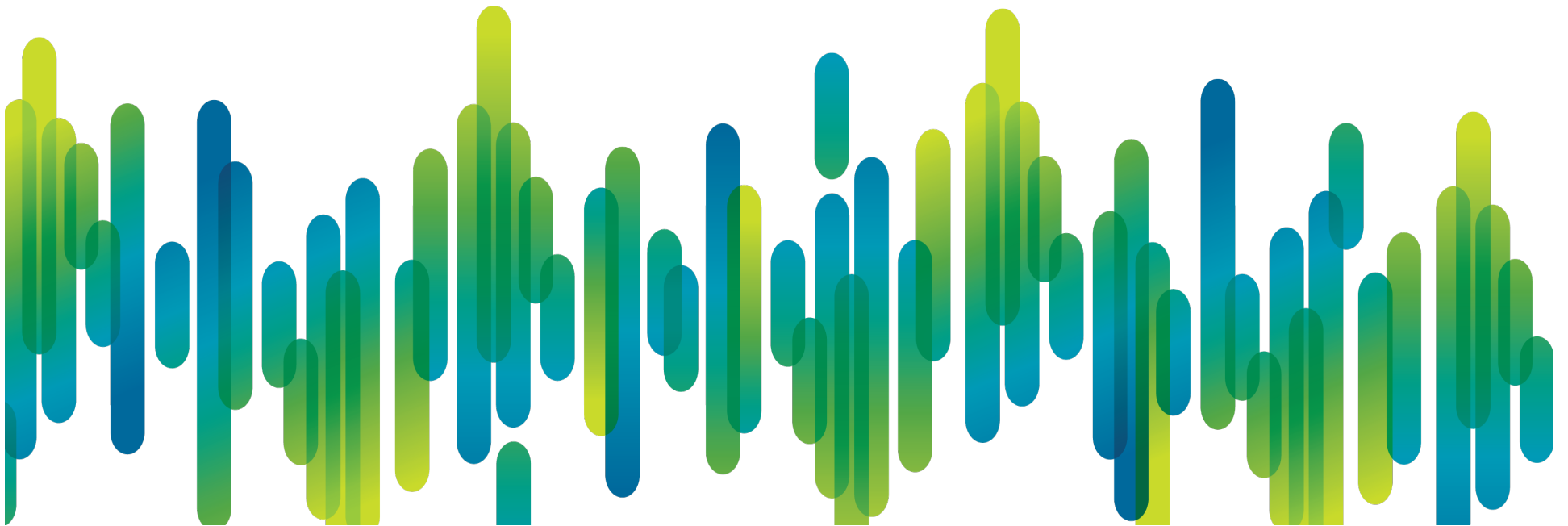

Thank you.

