



Cisco Networkers
2009

January 26-29 Barcelona, Spain

Next Generation Architectures for Cable



BRKBBA-2005

John Knox

Housekeeping

- We value your feedback- don't forget to complete your online session evaluations after each session & complete the Overall Conference Evaluation which will be available online from Thursday
- Visit the World of Solutions
- Please remember this is a 'non-smoking' venue!
- Please switch off your mobile phones
- Please make use of the recycling bins provided
- Please remember to wear your badge at all times including the Party

Agenda

- Introduction – Where we stand today
- DOCSIS 3.0 overview
 - Downstream & Upstream Channel Bonding
 - DOCSIS Management for 3.0
 - Multicast and Video over DOCSIS
 - Enhanced DOCSIS Security
 - Introduction of IPv6
- Modular CMTS (M-CMTS) architecture
- Network Architecture design for Next Generation Services
- Summary

Introduction – Where we stand today



DOCSIS CATV plants in Europe

- All 4 EuroDOCSIS standards are used but most run EuroDOCSIS 1.1/2.0
- Downstream rates
 - 8Mhz in most of Europe, mostly 256QAM modulation
- Upstream rates
 - 1.6Mhz-6.4Mhz, QPSK, 16QAM & 64QAM
- Typically, out of 100+ channels on the DS, only one or two is for DOCSIS, the rest for video (digital or analogue)
- The distribution network HFC. A FN (fiber-node) converts the optical signal to an electrical signal over coax.
- An FN typically serves 500 homes (HHP – house holds passed)
- A typical EuroDOCSIS configuration:
 - Single/Dual downstream channel is split to 4 FN
 - In this configuration about 2000 homes are passed by a DS. (800-1000 subs/DS as not all homes are connected)
 - Each FN has a single upstream frequency



Theoretical Bit Capacity of the HFC Plant

HFC Downstream is ~96 channels. At 256QAM: 96 channels * 52 Mbps =	~ 5 Gbps per FN
At one optical transmitter per 500 HHP FN: 5 Gbps / 500 HHP =	~ 10 Mbps per HHP
# of HDTV streams per HHP with H.264 (AVC): 10 Mbps / 7 Mbps =	~ 1.4 HD streams per HHP
Data Capacity in a 100K HHP plant: 5 Gbps per FN * (100,000 HHP/500 HHP per FN)= 5 Gbps per FN * 200 FN =	~ 1 Tbps per small plant

Cable's Upside Bandwidth Potential

Case Study:

- 100K HHP HFC plant with 500 HHP per Fiber Node
- Service Group (SG) is the # of FN with the same service offering

Bandwidth Used Today

÷

Total available Bandwidth

Service	Channels	Digital BW	# SG	Capacity
Analogue	59	62%	x 3.75 Mbps	x 1 SG = 0.22Gbps .5%
Digital	20	21%	x 52 Mbps	x 1 SG = 1 Gbps 2.2%
VOD	8	8%	x 52 Mbps	x 50 SG = 20 Gbps 45%
DOCSIS	9	9%	x 52 Mbps	x 50 SG = 23 Gbps 52%
Total	96			44 Gbps

Capacity	96	x 52Mbps	x 200 SG =	1000 Gbps
----------	----	----------	------------	-----------

Efficiency 4.4%



Change the Plant Infrastructure



Re-organizing the bits on the plant

DOCSIS 3.0 Overview - State of the Art IP Network



DOCSIS 3.0 Features

- Channel Bonding
 - Upstream Channel Bonding
 - Downstream Channel Bonding
- MAC Layer
 - Topology and ambiguity resolution
 - Latency and Skew measurements
 - CM Status and Control
- Security
 - Enhanced Traffic Encryption
 - Enhanced Provisioning Security
- Network Management
 - CM Diagnostic Log
 - Enhanced Signal Quality Monitoring
 - IPDR Service Statistics Reporting
 - Capacity Management
- IPv6
 - IPv6 Provisioning & Management of CMs
 - Alternative Provisioning Mode & Dual-stack Management Modes for CMs
 - IPv6 Connectivity for CPEs
- IP Multicast
 - Source Specific Multicast (SSM)
 - PHS, QoS, and Authorization
 - IGMPv3/MLDv2
- Physical Layer
 - Extended US/DS Freq Range
 - S-CDMA Active Code Selection
- Business Services over DOCSIS
 - Layer 2 Virtual Private Networks
 - Support for T1/E1 Emulation

Downstream Bonding



Channel Bonding

- In a nutshell, channel bonding means data is transmitted to or from CMs using multiple individual RF channels instead of just one channel
- Channels aren't physically bonded into a gigantic digitally modulated signal; bonding is logical

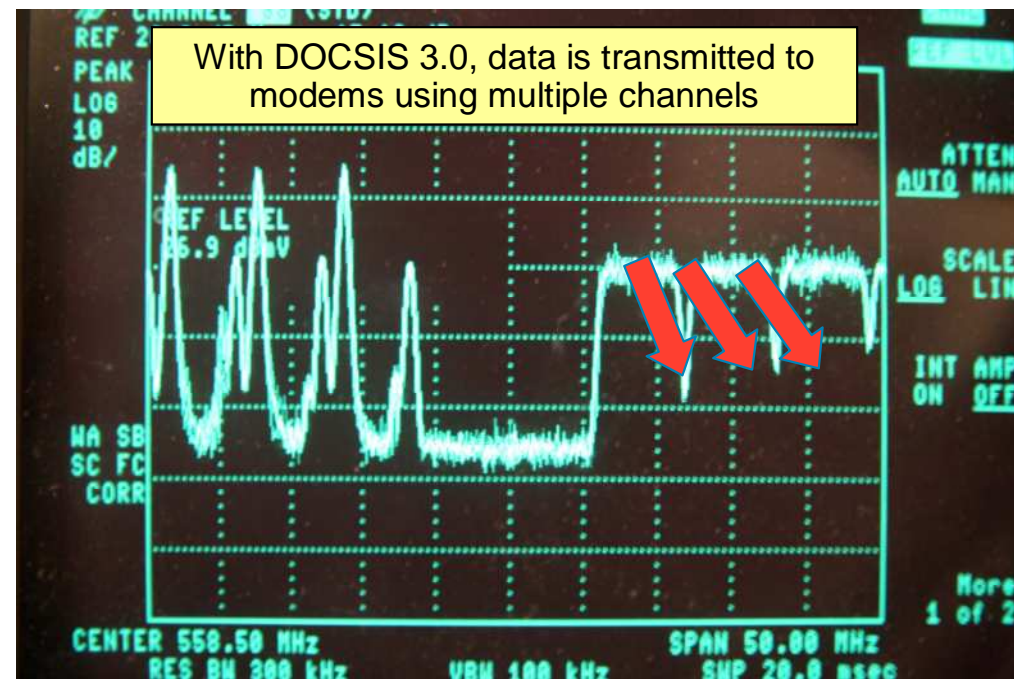
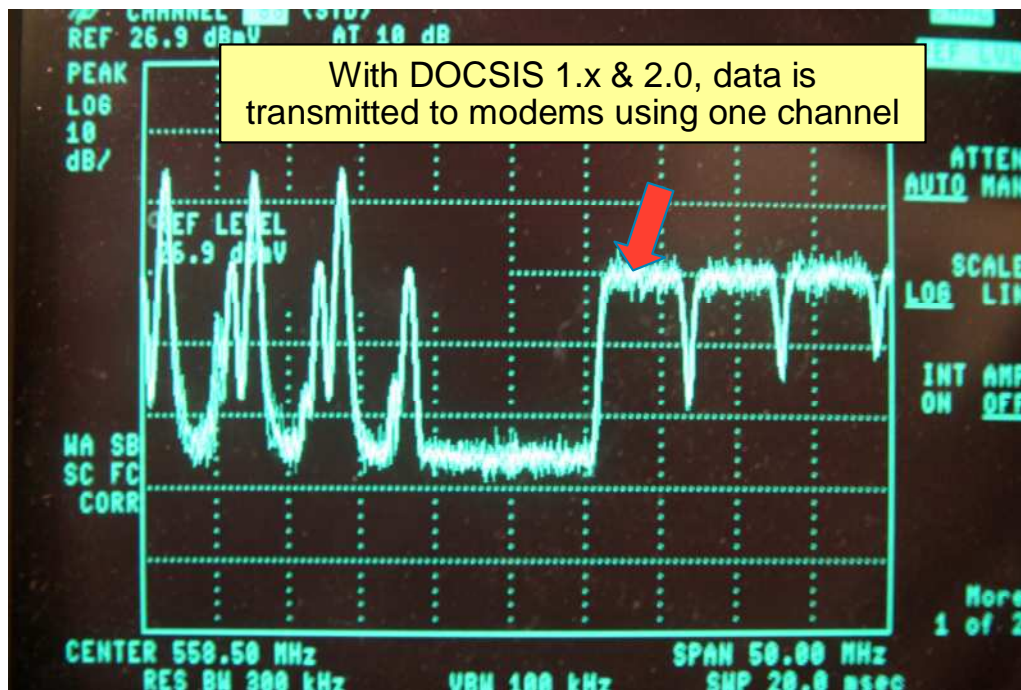

Downstream Bonding

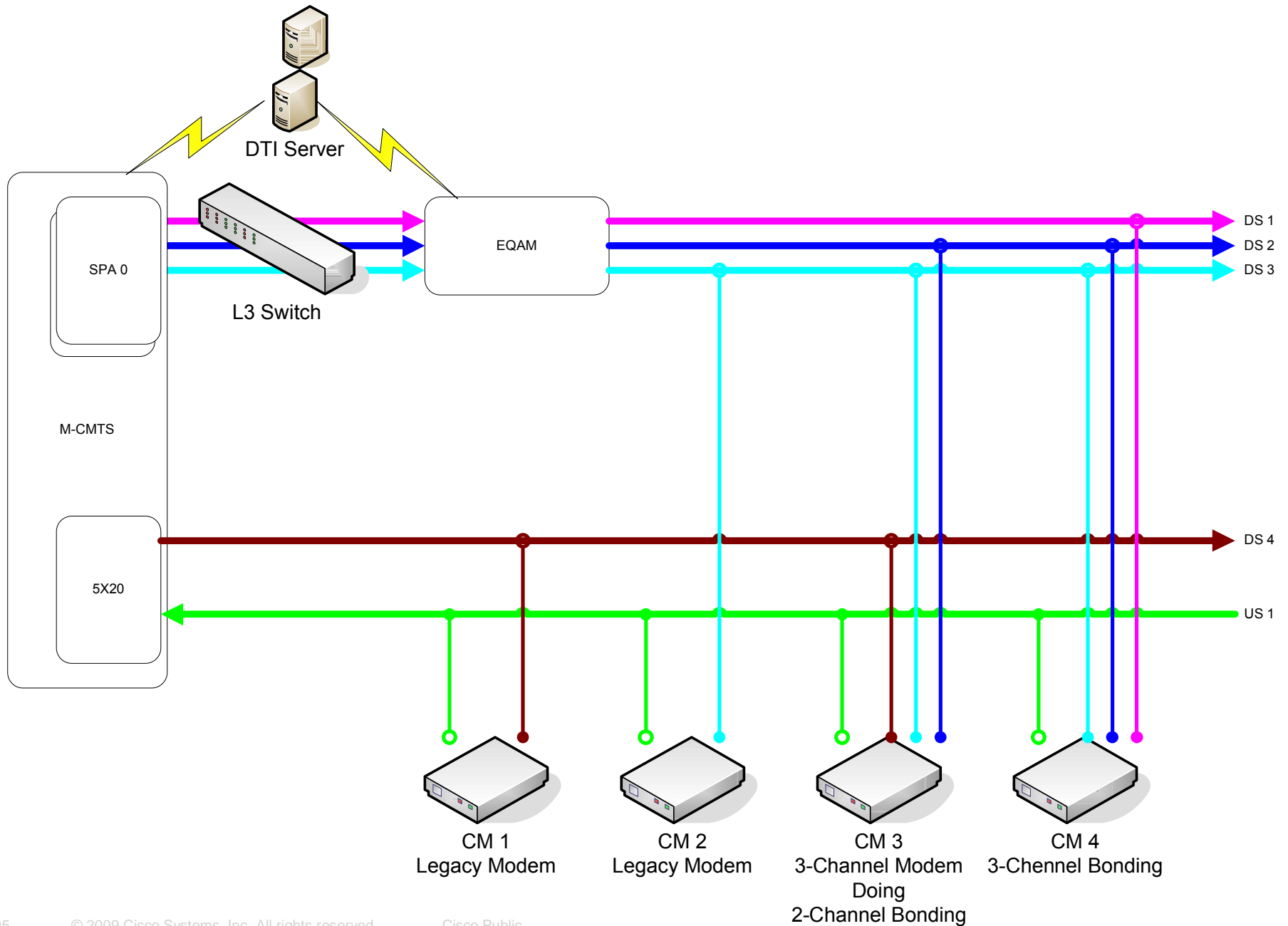

What is downstream channel bonding?

- An MLPPP like technology
- Each packet is tagged with a sequence number and a re-sequencing index:
 - The sequence number is used to place packets back in order
 - The re-sequencing index (DSID – downstream service ID) is used so that each flow, or group of flows, could be re-sequenced independently.

DSID – many meanings for single field

- The DSID serves as:
 - A re-sequencing index
 - DSIDs can be used only on a specific set of QAMs
 - A tag to identify (and filter on) multicast flows
 - Associated with an interface mask on the CM for multicast replication
- How is the DSID related to service flows ?
 - Not directly related
 - Several service flows can map to one DSID
 - Several DSIDs can map to a single service flow
 - DSIDs and service flows are signaled independently, in other words, there is no messages that associated a service flow to a DSID

Downstream Bonding cont'd

- Changes were also made to the DS PHY
 - 112 Mhz – 860 Mhz (Mandatory)
 - 85 Mhz – 1G (optional)
- Power Per Channel
 - Maximum power per channel depends on the amount of channels on one RF port
 - Range of commanded channel power is $\geq 8\text{db}$

Number of Channels	Max Power / Channel
1	60
2	56
3	54
4	52

Downstream Channel allocation

- Before allocation, CM communicates its physical constraints to the CMTS
 - Using a “Receive Channel Profile” (RCP)**
 - CMTS decides upon given constraints**
- CMTS defines a “Receive Channel Set” (RCS)
 - Set of d/s a CM is configured to receive**
- RCC “Receive Channel Config” Can be set by Registration, CLI or LB using DBC “Dynamic Bonding Change”

Upstream Bonding



Upstream Channel Bonding

- Upstream bonding

Single flow can consume all BW on multiple USs

- Continuous Concatenation & Fragmentation (CCF)

Improved form of concatenation and fragmentation that is needed for DOCSIS 3.0 operation

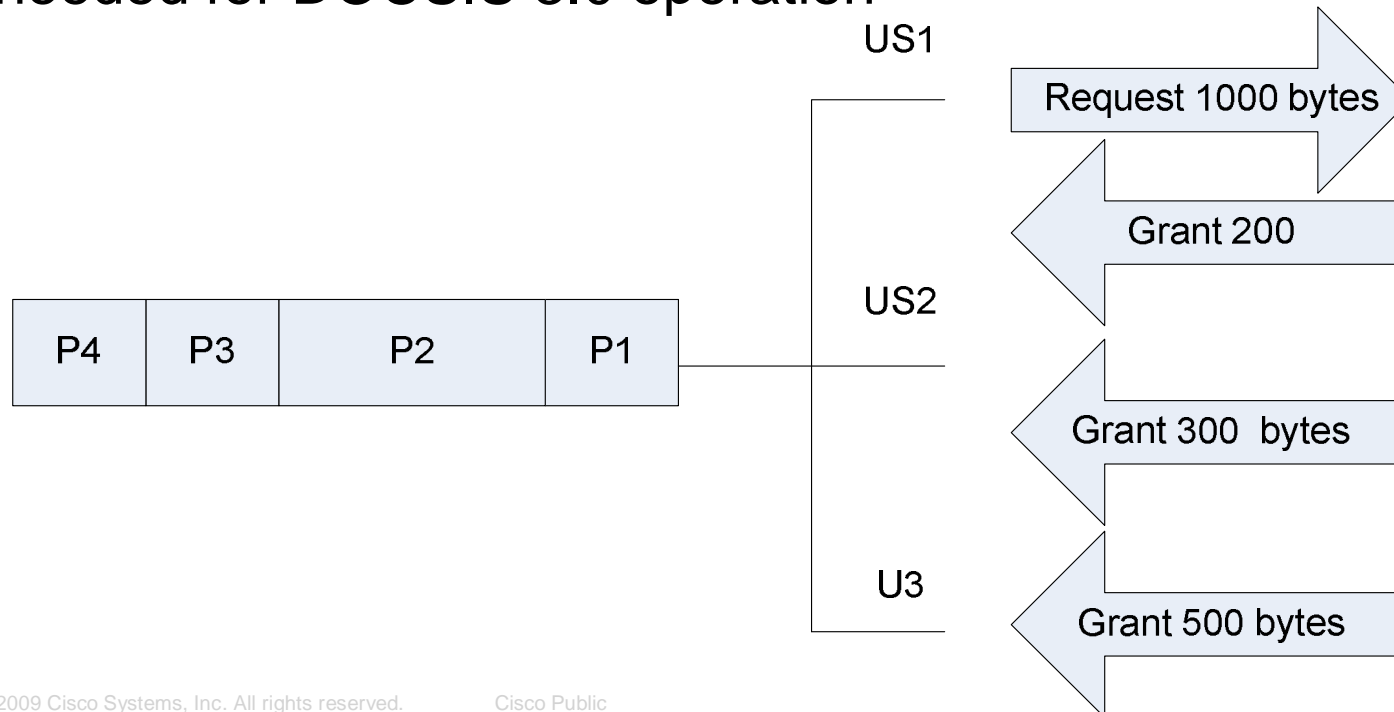

Multi-SID vs. Multi-request

- Multiple outstanding grants per SID, or multiple SIDs with a single outstanding request, or both.
 - “Multi-SID”, multiple SIDs, one grant per SID.
 - The risk : sid inflation
 - “Multi-outstanding requests”
 - The risk : stale bytes in the output buffer if requests are lost.
- To work around this limitation its recommended to have
- at least 2 SIDs used for requesting – if one stalls the other still works.

Upstream MAC: Channel Bonding

- CMTS is free to use all burst profiles for data

Thanks to CCF, and to the fact that requests are made in bytes, the CMTS is free to use any IUC to grant data (IUC5,6,9,10,11) – this opens the path to new forms of spectrum management and reduces the need for logical channels.

- The CMTS will also use SID Clusters

The CMTS is NOT required to assign the same SID numbers across all upstreams. This set of those single SIDs that are spread across the upstreams is called a “SID Cluster”

- SID Cluster Group

A group of several SID clusters used to request bandwidth

- Requests made based on bytes, not minislots.

Upstream Bonding power considerations

Required power per channel for N channels combined onto a single RF port:	Required power in dBmV per channel
N = 1	60 dBmV
N = 2	56 dBmV
N = 3	54 dBmV
N = 4	52 dBmV
N > 4	60 – ceil [3.6*log ₂ (N)] dBmV

DOCSIS Management for 3.0



MAC Domain Descriptor (MDD)

- Information is conveyed to bonding capable modems by MDD (MAC Domain Descriptor)

MDD is transmitted every 2 seconds

MDD is transmitted on **ALL** bundled primary capable channels associated with the WB channel in the cable fiber-node table

Modem must re-register if 3 consecutive MDD are missed

- Only MDDs relevant for that fiber-node are sent
- Primary MDD messages can be sent on the legacy DS if it is the only Primary capable DS channel in the MD. Secondary MDD messages are sent on the remote channels
- When a remote channel is added to a MD and the corresponding Modular interface line protocol is UP, a Primary MDD message is sent on the remote DS. Secondary MDD's are sent on the non-primary capable channels.

What's in a MAC DOMAIN Descriptor

- Information for each Downstream Service Group comprised of the MD-DS-SG-ID along with the set of DCIDs that comprise the MD-DS-SG
- Channel parameters (e.g., frequency, modulation) for each downstream channel in the MAC Domain as well as an indication of whether that channel is Primary Capable
- Upstream Active Channel List;
- Upstream Ambiguity Resolution Channel List;
- Upstream Frequency Range
- Downstream Ambiguity Resolution Frequency List containing a list of downstream frequencies that the CM uses to resolve the MD-DS-SG-ID

MDD

- MDD MESSAGE
- FRAME HEADER
- FC - 0xC2 ==
- MAC_PARM - 0x00
- LEN - 0x124
- MAC MANAGEMENT MESSAGE HEADER
- DA - 01E0.2F00.0001
- SA - 0005.00E6.CCA8
- msg LEN - 112
- DSAP - 0
- SSAP - 0
- control - 03
- version - 04
- type - 21
- change_count - 0x02
- num_fragments - 1
- seq_num - 1
- : **dcid** - **180 ==**
- MDD TLV, Total TLV size - 264

- MDD TLV
- Downstream Active Channel List
- Channel ID: 180
- Frequency: 453000000Hz
- Modulation Order/Annex: 256 QAM/Annex A
- Primary Capable: Primary-Capable
- CM-STATUS Event Bitmask: 0x06
 - MDD Timeout
 - QAM FEC failure
- MAC Domain Downstream Service Group
- MD-DS-SG ID: 1
- Channel IDs: 180
 - 24
 - 25
 - 26
- Downstream Ambiguity Resolution Frequency List
- Frequencies: 300000000Hz
 - 308000000Hz
 - 316000000Hz
 - 548000000Hz
 - 556000000Hz

DS Channel Bonding - RCS, BG and DSIDs

- **RCS** (receive channel set) defines the total set of QAMs the CM needs to listen to. Many different modems can use the same RCS.
- The set of channels that packets belonging to a **DSID** can be sent on are a “bonding group” (**BG**).
- Different modems can use the same BG, but must use different DSIDs, unless used for multicast service.

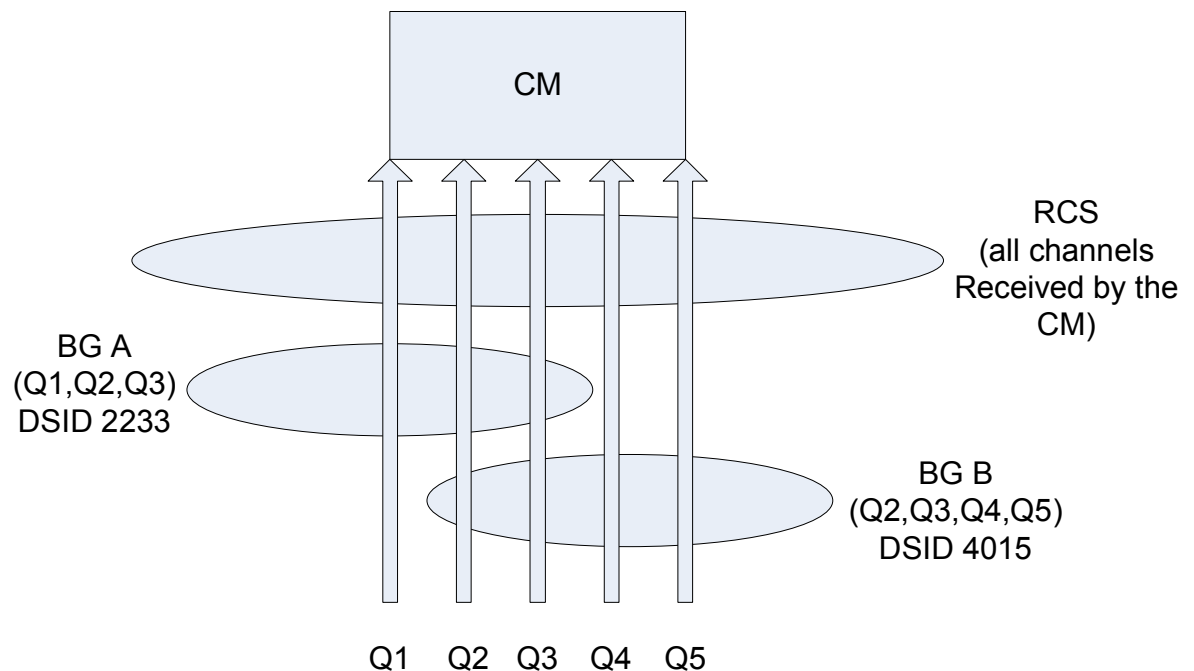

Example - D/S and U/S frequency assignments

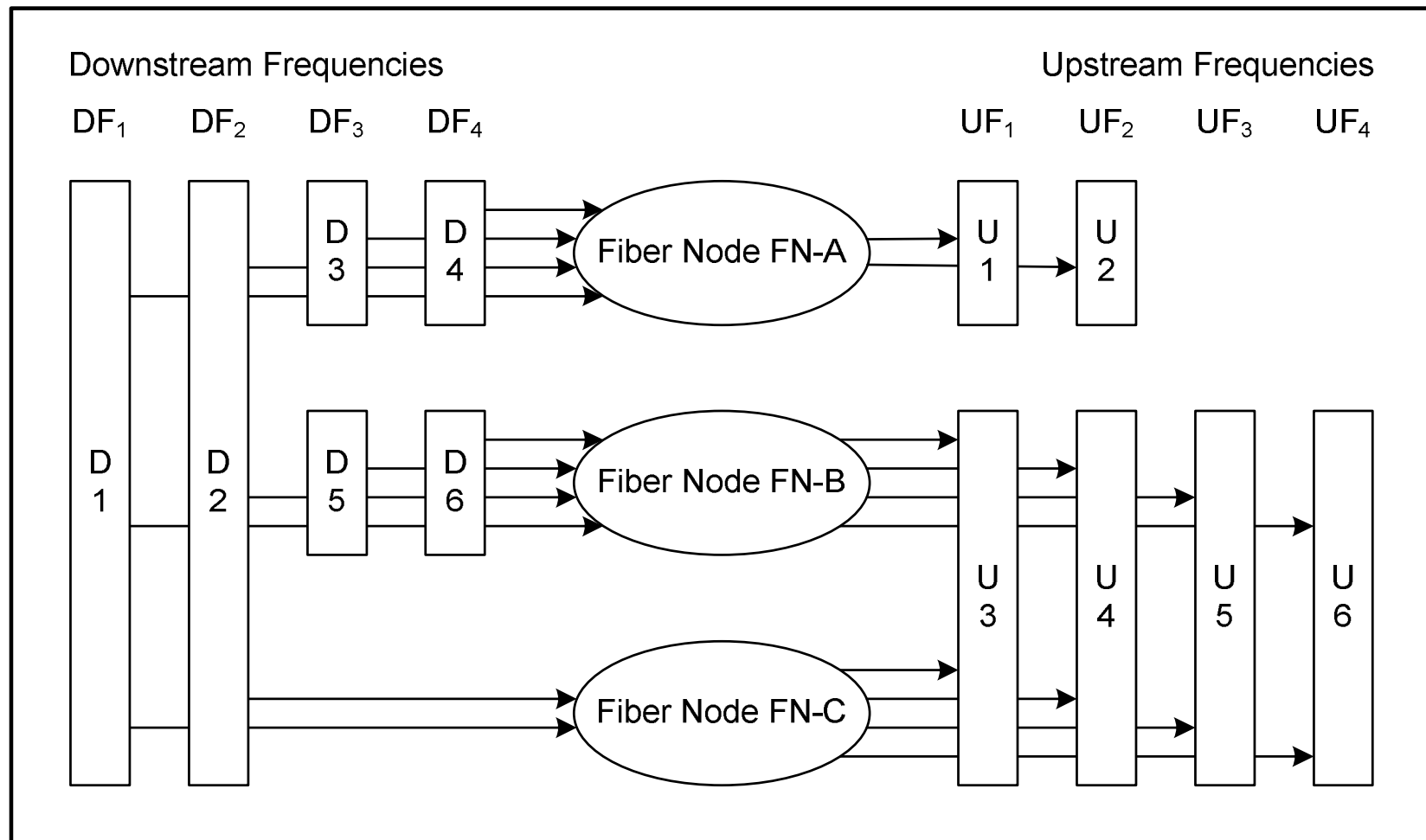

MD-CM-SG channel assignment

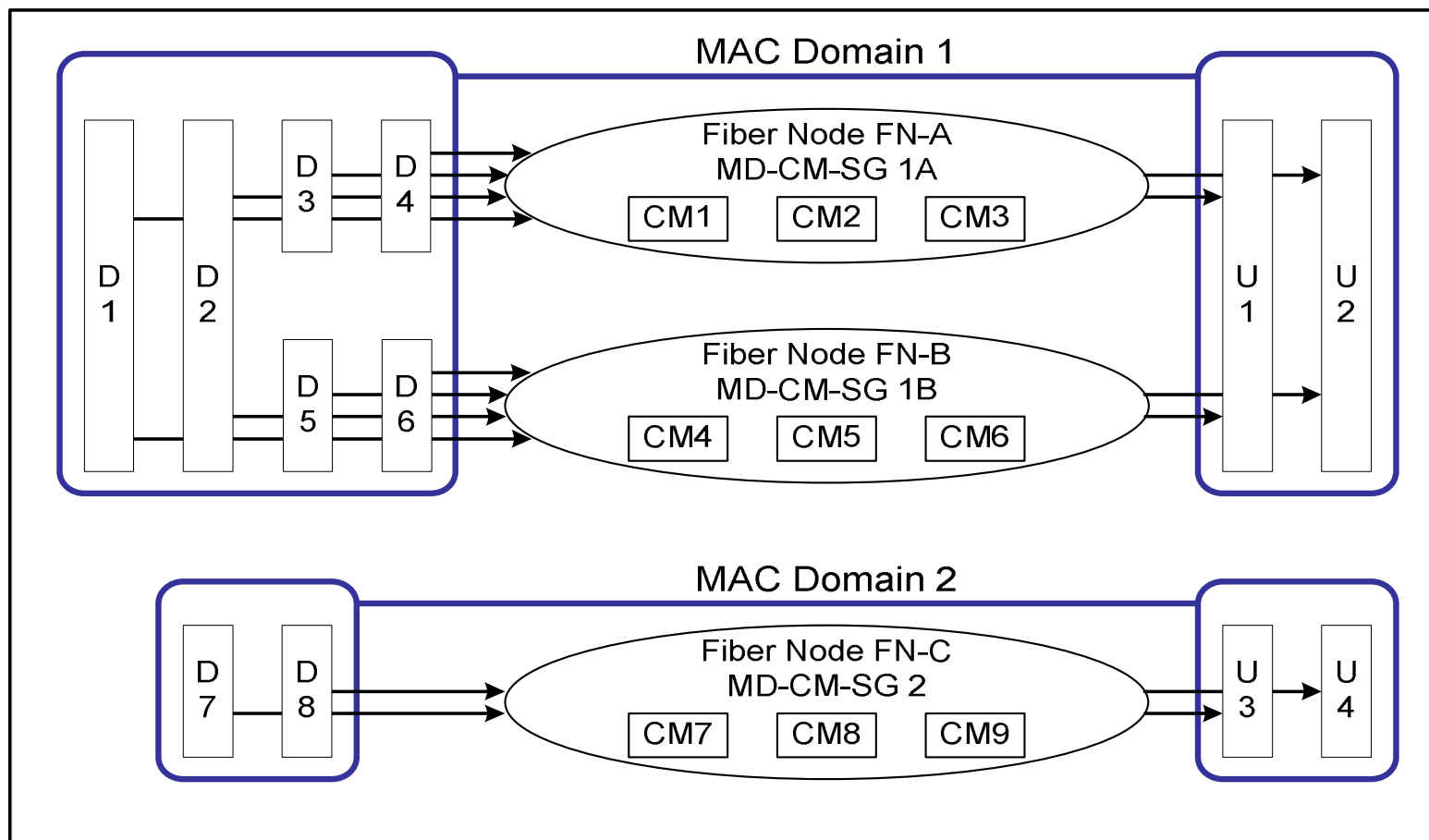

A "MAC Domain CM Service Group" (MD-CM-SG) is the set of downstream and upstream channels from the same MAC Domain, all of which reach a single CM. An MD-CM-SG corresponds to a general load balancing group because it forms the set of channels among which a non-bonding CM can be moved while remaining registered in the same MAC Domain. For bonding CMs, an MD-CM-SG represents the set of channels among which traffic on bonded service flows can be scheduled while the CM remains registered to the same MD.

Multiple MAC Domains Per Fiber Node

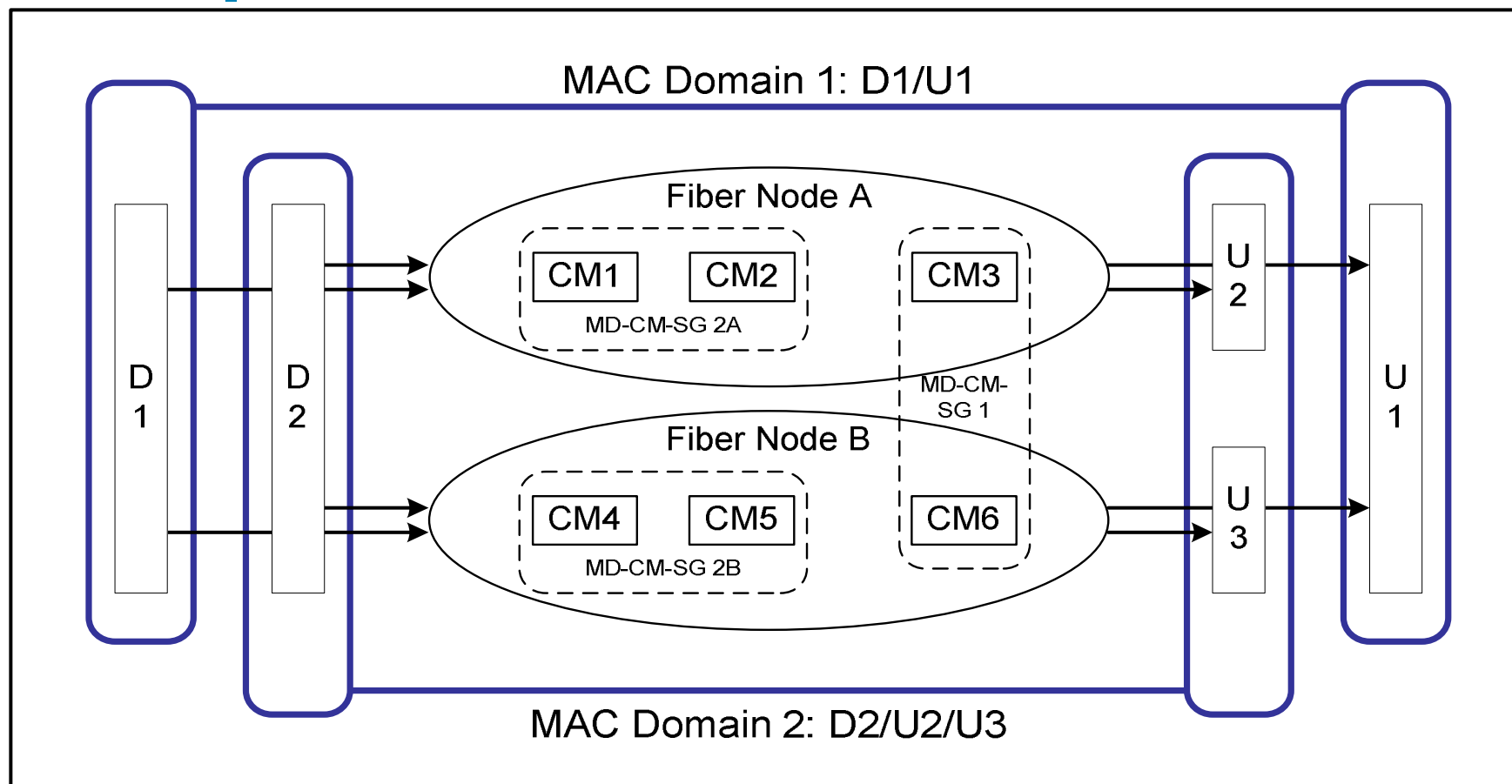

For simplicity, it is recommended that all DOCSIS channels from a CMTS reaching a fiber node be configured into the same MAC Domain. It may be desired, however, to define separate sets of downstream and upstream channels that reach the same fiber node into different MAC Domains in order to provide separate services. For example, business customers or set-top-box CMs may be desired to have entirely separate service from residential high-speed-data CMs, and may be configured onto separate MAC Domains.

CM-SG

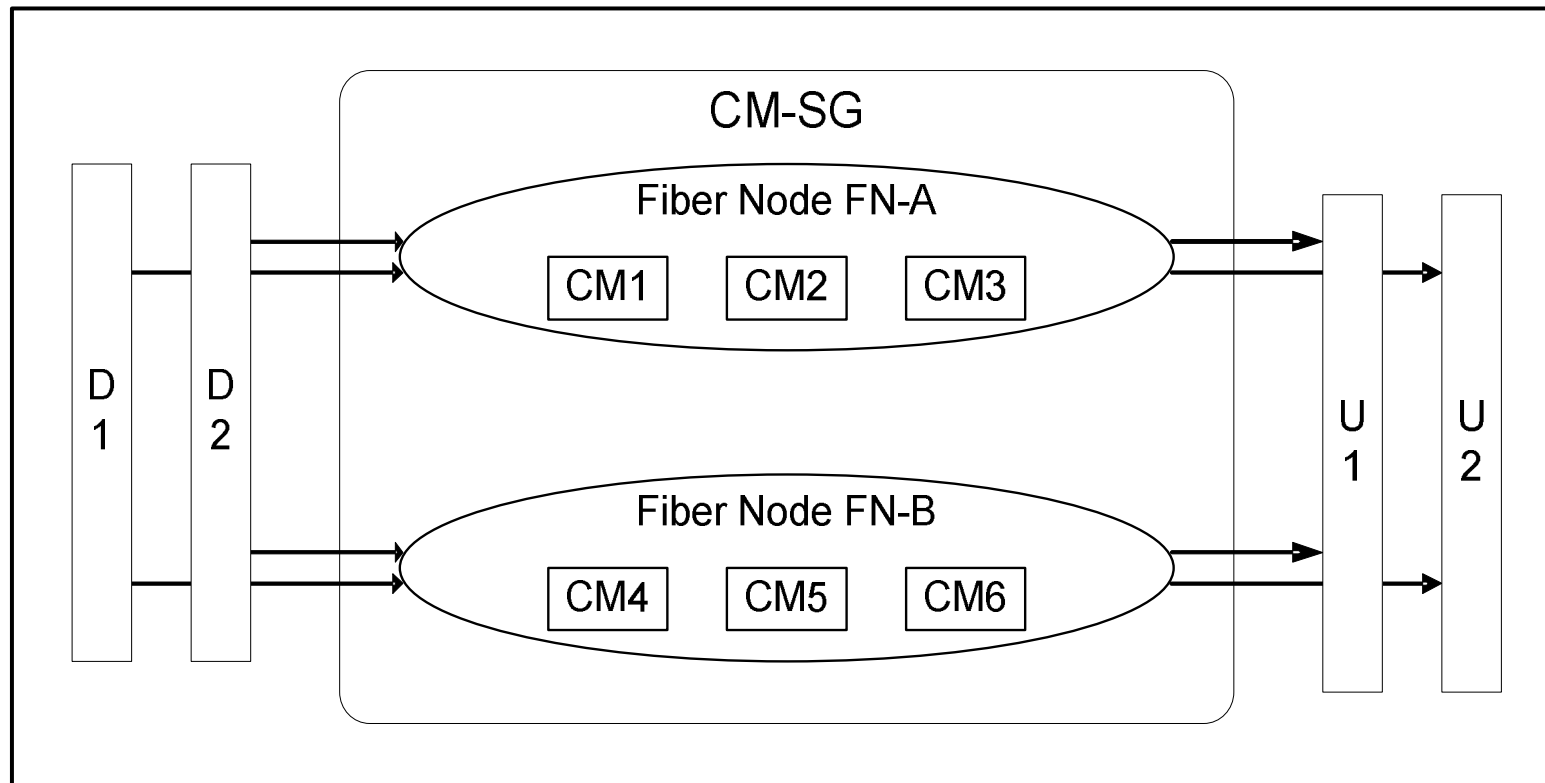

A "Cable Modem Service Group" (CM-SG) is formally defined as the complete set of CMTS channels—both upstream and downstream—that reach a single cable modem. Thus, a CM-SG usually corresponds to the channels reaching a single fiber node, and the term "CM-SG" can generally be considered to be synonymous with "fiber node".

Channel Bonding Considerations

- A "Provisioned" Bonding Group is a configured set of downstream or upstream channels on the same MAC Domain that reach at least one fiber node in common.
- The next slide takes the Service Groups and MAC Domains defined in earlier slides, and overlays a variety of provisioned Downstream Bonding Groups (DBG) and Upstream Bonding Groups (UBG). In addition to provisioned bonding groups, a CMTS may dynamically create downstream or upstream bonding groups.
- Because a single CM must be able to reach all channels of a bonding group, a CMTS SHOULD restrict configuration of provisioned bonding groups such that all channels reach at least one fiber node in common

Bonding Group example

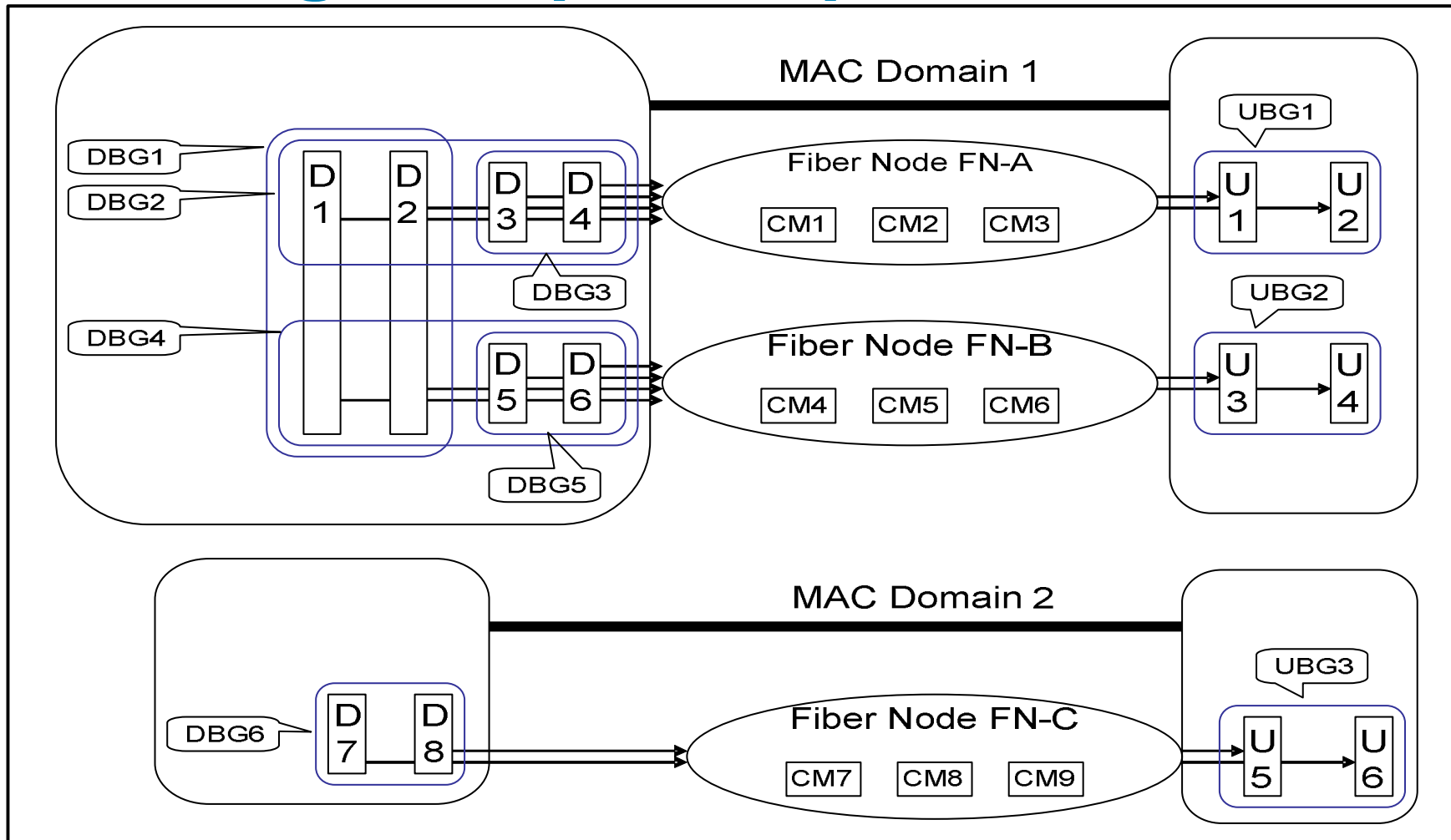

The Downstream Bonding Groups depicted include DBG1{D1,D2}, DBG2{D1, D2, D3, D4}, DBG3{D3, D4}, DBG4{D1, D2, D5, D6}, DBG5{D5, D6}, and DBG6{D7, D8}. The Upstream Bonded Channel Sets depicted include UBG1{U1,U2}, UBG2{U3,U4}, and UBG3{U5,U6}.

Fiber Node definition

- The Fiber-node describes the plant topology, the set of upstream and downstream channels that can be seen by a group of bonding capable modems only.

Fiber Node examples

- **Case 1: One PC – FN-A (DBG 1,2, & 3)**

 - cable fiber-node 1

 - downstream cable 5/0/0

 - downstream modular-cable 1/0/0 rf-channel 1-4

 - upstream connector 1-2

- **Case 2: One PC – FN-B (DBG 1,4 & 5)**

 - cable fiber-node 2

 - downstream modular-cable 1/0/0 rf-channel 1-2 5-6

 - upstream connector 3-4

- **Case 3: Two PCs – FN-C (DBG 6)**

 - cable fiber-node 3

 - downstream cable 5/0/0

 - downstream modular-cable 1/0/0 rf-channel 7-8

 - upstream connector 5-6

Fibre Node examples Best practice

- The Fiber-node describes the plant topology, the set of upstream and downstream channels that can be seen by a group of **bonding capable modems only**.

- **Example 1: One PC – 8 Secondary Channels**

 - cable fiber-node 1

 - downstream cable 5/0/0

 - downstream modular-cable 1/0/0 rf-channel 0-7

 - upstream connector 0-3

- **Example 2: One PC – 8 Secondary Channels**

 - cable fiber-node 1

 - downstream modular-cable 1/0/0 rf-channel 1-3 5-7 9

 - upstream connector 0-3

- **Example 3: Two PCs – 8 Secondary Channels**

 - cable fiber-node 1

 - downstream cable 5/0/0

 - downstream cable 5/0/1

 - downstream modular-cable 1/0/0 rf-channel 1-8

 - upstream connector 0-3

Channel Group Domain definition

- A CGD “Channel Group Domain is a MAC DOMAIN that contains multiple “primary capable channels”
- A “M x N Domain represents the total “primary and secondary” channels with in the DOMAIN

Conceptual representation of CGD

MC5x20 (Slot 5/0)

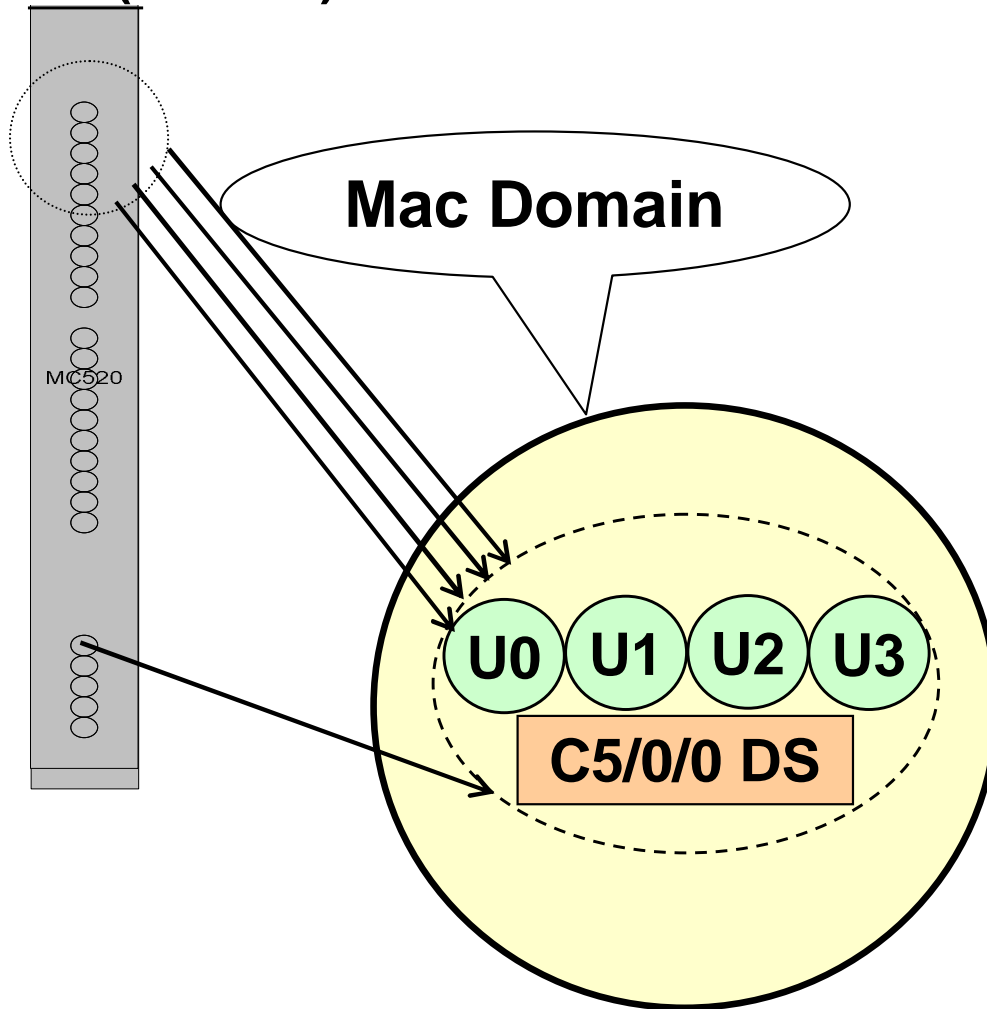

Conceptual representation of CGD

MC5x20 (Slot 5/0)

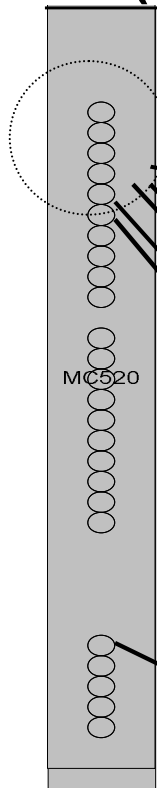

Mac Domain = CGD

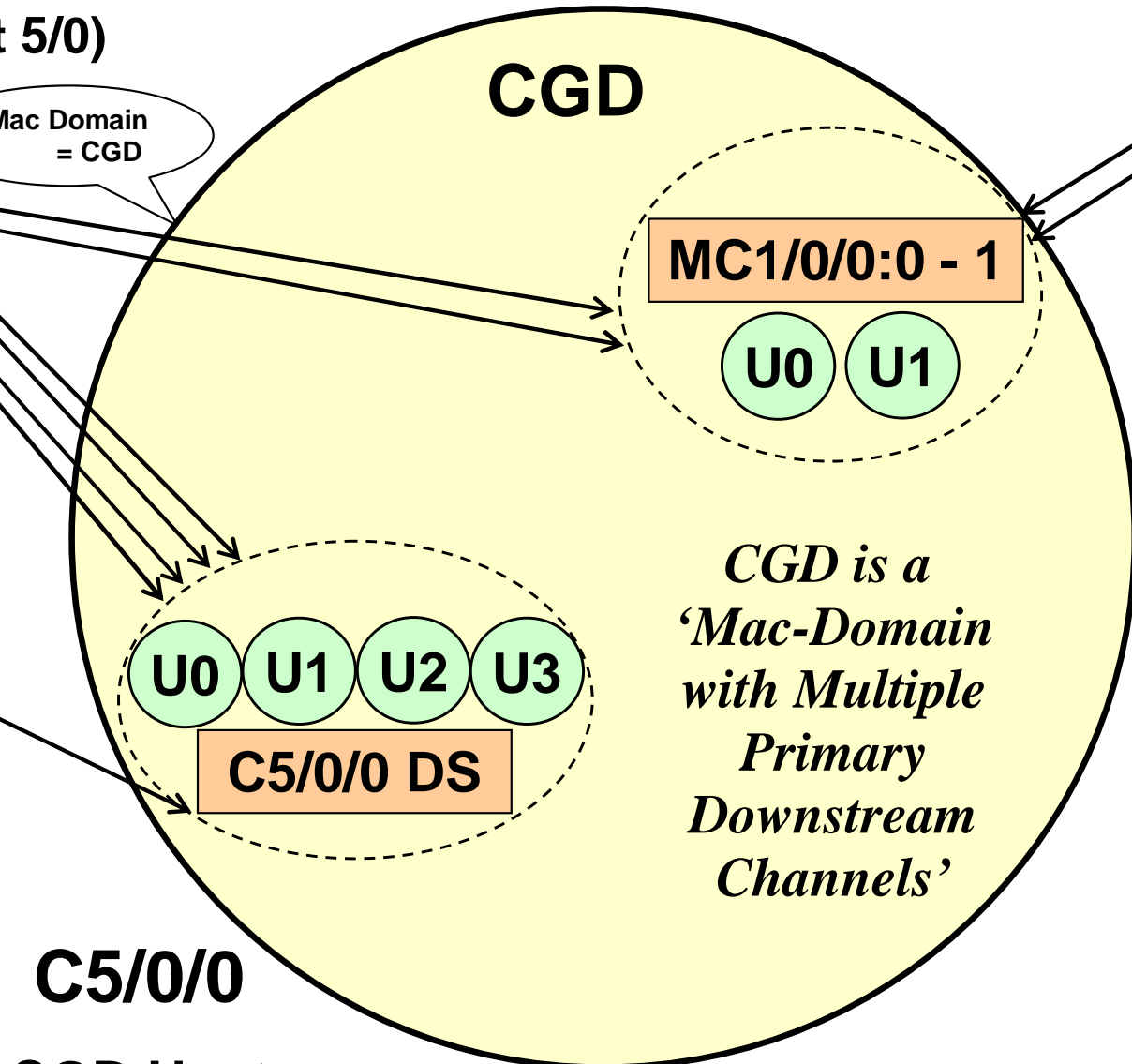

CGD is a 'Mac-Domain with Multiple Primary Downstream Channels'

C5/0/0
CGD Host

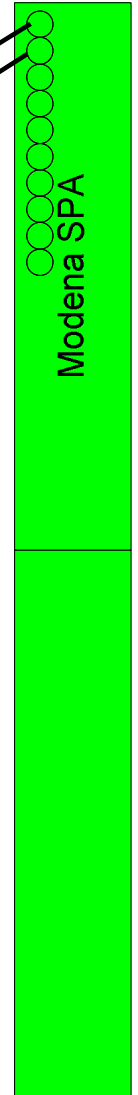

DS Bonding SPA (slot 1/0)

Other definitions

- **RM- Receive Module-** refers to a CM sharing physical common components eg Tuner constraints, capture b/w
- **RCP- Receive Channel Profile** –CM must report its constraints on ch allocation by sending capabilities- below,

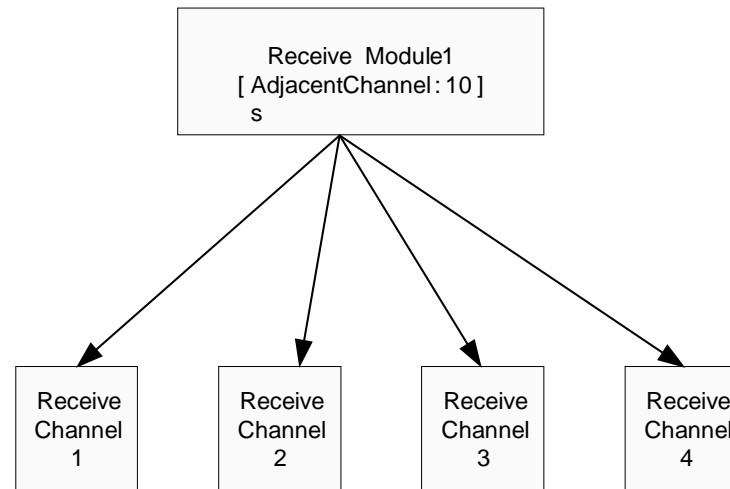

- **RCC- Receive Channel Configuration** will be the Annex Centre frequency , modulation and interleave
- **TCC- Transmit Channel Set-** Set of upstream reported in the TSC

DOCSIS 3.0 Enhanced Multicast



Perspective on Multicast

- Enhanced Multicast in DOCSIS is key to providing Video over DOCSIS (VDOC) for the replacement of broadcast video and live video feeds (news, wars, traffic chases, sports, etc.)
- Multicast existed in DOCSIS 1.1/2.0 but did not receive much use.

CM would snoop IGMP join. This has been eliminated.

- D3.0 adds -

Source Specific Multicast (SSM)

PHS, QoS, and Authorization

IGMPv3/MLDv2

Source Specific Multicast-SSM

- Feature Description

Delivery of multimedia (audio/video) services from one source to multiple subscribers' CPEs (IPv4 & IPv6) based on customer request

- Why was this incorporated?

Previous versions did not support MSO directed multicast (any member of the multicast group could transmit)

- Benefits

Enables operators to offer broadcast-like services over DOCSIS based on subscriber demand (e.g. IPTV service)

Enables bandwidth efficient on-demand multimedia services as compared with unicast

Facilitates offering of interactive video/audio and data services

QoS Support for Multicast

- Feature Description

 - Provides guaranteed bandwidth for multicast sessions

 - Provides ability to control the amount of bandwidth that can be used by multicast traffic that is not part of an MSO service offering

- Why was this incorporated?

 - Required to offer entertainment quality video services over DOCSIS

- Benefits

 - Enables differentiation of QoS-enabled multicast services

 - Enables service level guarantees to be offered to the end customer

 - Enables offering of QoS-enabled packages to third parties

VDOC Broadcast

- The VDOC Broadcast feature facilitates broadcasting video over DOCSIS.
- Video streams are broadcast to one or more downstream RF channels using static multicast.
- Depending on the video stream selected for viewing by the IP set-top box, CM is tuned to the appropriate RF channel carrying the specific video stream.
- The process to broadcast video over the cable is given below.
 1. When a user selects a channel, the IP set-top box sends an IGMP join message to the specific bonding group.
 2. The CMTS locates the secondary bonding group that has the video streaming channel and the RCC template that contains the channel corresponding to the secondary bonding group.
 3. If the cable modem does not respond to the specific RCC, the CMTS sends a DBC-REQ message to the modem. The DBC-REQ message contains the DSID and a new RCC that contains frequencies for the primary bonding group and the secondary bonding group that was selected in Step 2.
 4. The cable modem retunes to the new channel and receives the video stream.

DOCSIS 3.0 Enhanced Security

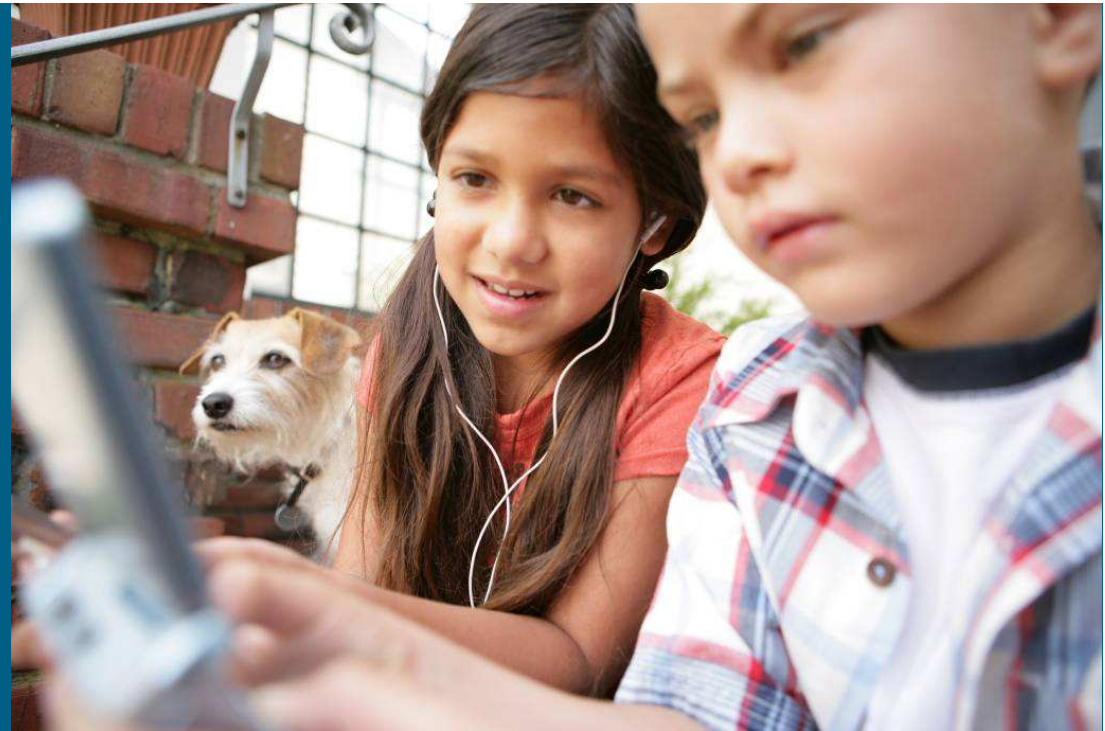

Perspective on Security

- DOCSIS has great link level security
 - BPI+: Baseline Privacy
 - DES encryption
 - X.509 certificates
- Security enhancements are motivated primarily to prevent theft of service
- Secure provisioning of CMs
 - Unauthorized CMs can be prevented network access
- Encrypt data traffic between the CM and CMTS
 - Best effort / QOS Enabled IP data traffic
 - Multicast group traffic

Enhanced Security – Additional Features

- AES required on CM and CMTS for DOCSIS 3.0

Provides stronger traffic encryption, 128 bit Advanced Encryption Standard (AES) for user's data

National Institute of Standards and Technology (NIST) has declared single DES as not acceptable for government applications.

Industry was concerned about public perception. DES is required for backwards compatibility

- Source-verify is now standardized

- ARP rate-limit

- Cert revocation: CRL + OCSP

- Enhanced software validation

Early Authentication and Encryption (EAE)

- Increases security of the CM provisioning process
 - Applies authentication before CM accesses MSO's operation support systems
 - Configuration file transfers encrypted
- MSO's have experienced:
 - Denial-of-service attacks on MSO's operation support systems
 - Hacked modems were requesting unauthorized services
- Authenticate CM after Ranging/before DHCP
 - Network admission control
 - Eliminate possibility of bypassing authentication by manipulating configuration file
- Per CM traffic: encrypted using primary SA (security association)
- Configurable
- EAE Exclusion
- Can be enabled on a per CM or per MAC domain basis

Secure Provisioning

- Authentication reuse:

Encrypt DHCP, TOD, TFTP, and REG-REQ

- CMTS TFTP Proxy

CMTS acts as a TFTP server to the CM and as TFTP client to the provisioning server

This allows config parameters enforcement since CMTS receives the config file first from the Provisioning Server

Config file authorization

- New MIC hash algorithm: MMH

Certificate Revocation

- Feature Description

 - A more efficient method for the CMTS to check up-to-date certificate revocation status each time a CM attempts to authenticate

- Why was this incorporated?

 - Current certificate revocation method is cumbersome

- Benefits

 - Reduces operational complexity in managing un-trusted certificates across CMTSs

 - Facilitates sharing certificate revocation data across multiple MSOs

- Requirements and restrictions for deployment

 - Requires the operator have a security policy in place that governs the distribution and storage of certificate data

DOCSIS 3.0 IPv6



Perspective on IPv6

- Need for more IP Address Space - IPv6
 - IP Addresses per HH trend upwards from 2 to 8 by 2009
 - Address requirements could double over the next 2 years
 - End-point addressing; avoiding NAT and its limitations
- The IP backbone has IPv6; the home network will have IPv6 (Windows Vista will try IPv6 before IPv4).
 - IPv6 over DOCSIS provides the missing link.
- As a result, the MSOs will likely provide the first large scale deployment of IPv6 (outside of Japan).

Global Transparency

IPv6 Restores Global Transparency by Getting Rid of NAT

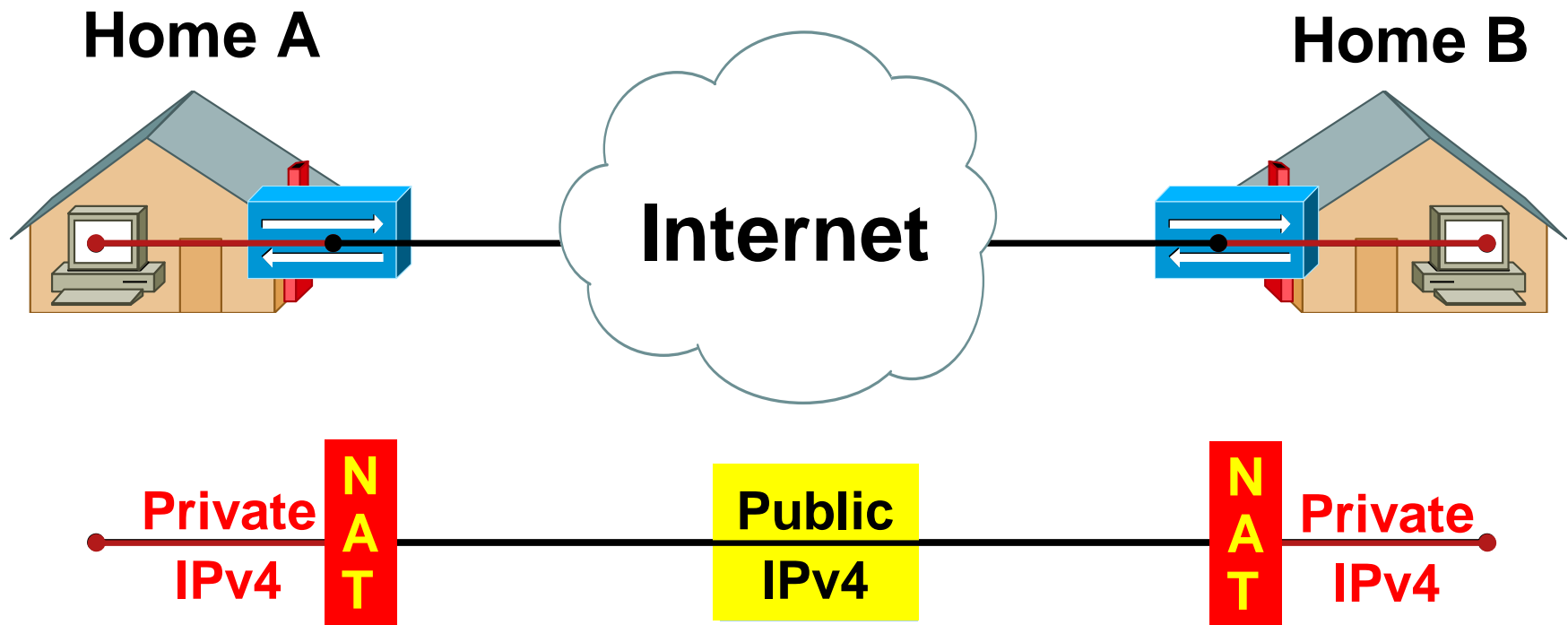

Plug and Play Home Networking

Premises Network(s), Auto-configuration Beyond DHCP



IPv6

Initial requirement:

- CM provisioning and management through IPv6 to reduce pressure on MSO IPv4 address space

IPv6 features are being defined and rolled out in two phases

- Phase 1:

Mandatory to implement, provides CM operation through IPv6

- Phase 2:

Software update only, provides IPv6 service to customers

IPv6 Features Phase 1

- Provisioning via DHCPv6
 - CM and CPE use DHCPv6 with additional options for address assignment and configuration
- IPv6 Forwarding at the CM
 - CM has IPv6 stack and is managed entirely through IPv6
 - CM bridges IPv4 traffic to CPE
 - CM can fall back to IPv4 provisioning and management if IPv6 fails
- IPv6 Forwarding at the CMTS
 - Forwards IPv6 as well as IPv4 traffic
 - New DHCPv6 options to inform CMTS of address assignment

IPv6 Features Phase 2

- "eRouter" in CM for IPv4/IPv6 data service to customers
- Minimal set of IPv6 forwarding to allow customer network
- Other features for CPE operation in customer network
 - Stateless address auto-configuration and DHCP for configuration
 - DNS proxy
 - DHCPv6 Prefix Delegation added for assignment of customer prefix
 - MIBs available for MSO management of eRouter

DOCSIS 3.x IPv6 Reference Architecture

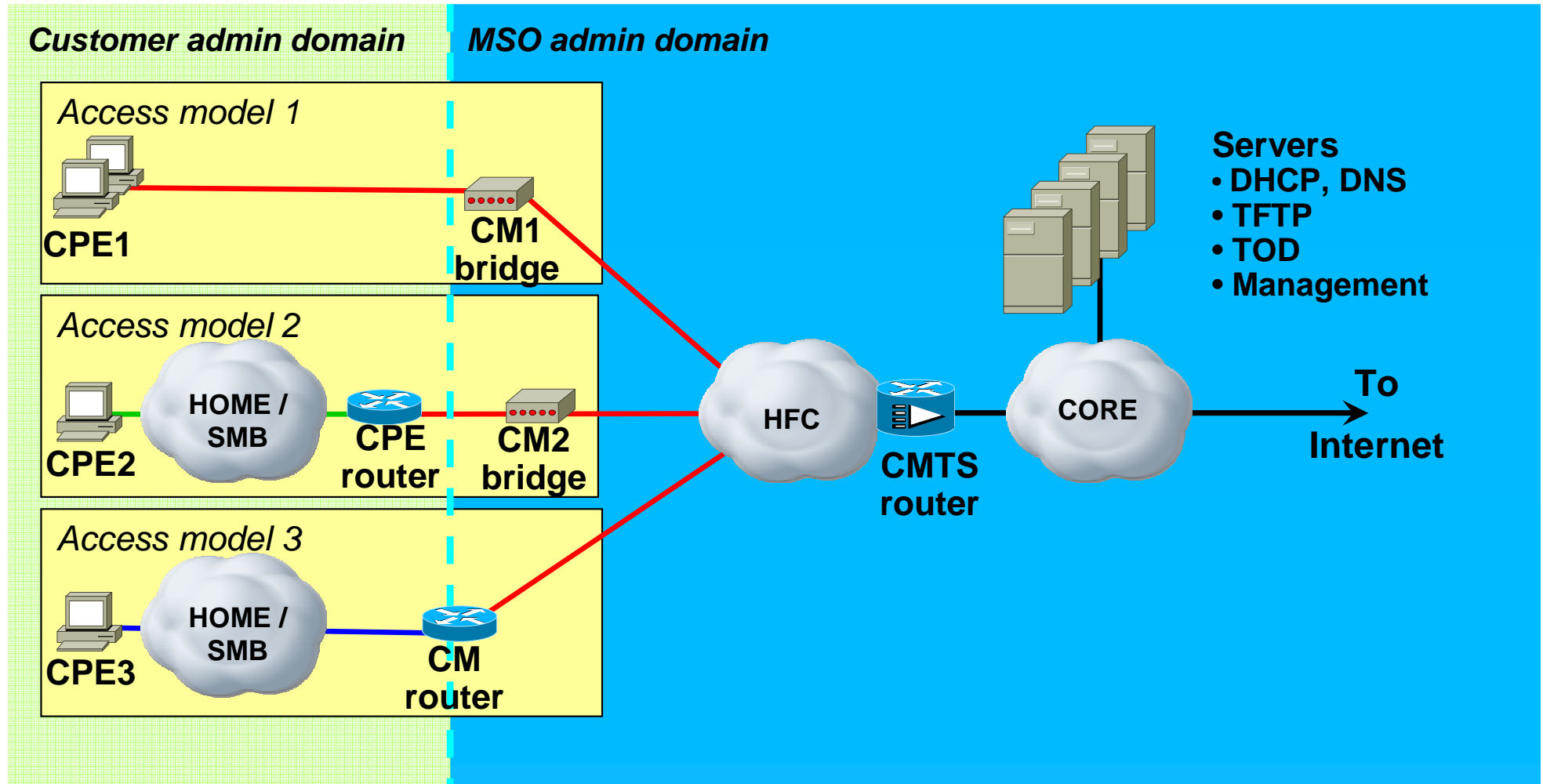

Modular CMTS



Integrated-CMTS Logical Functions

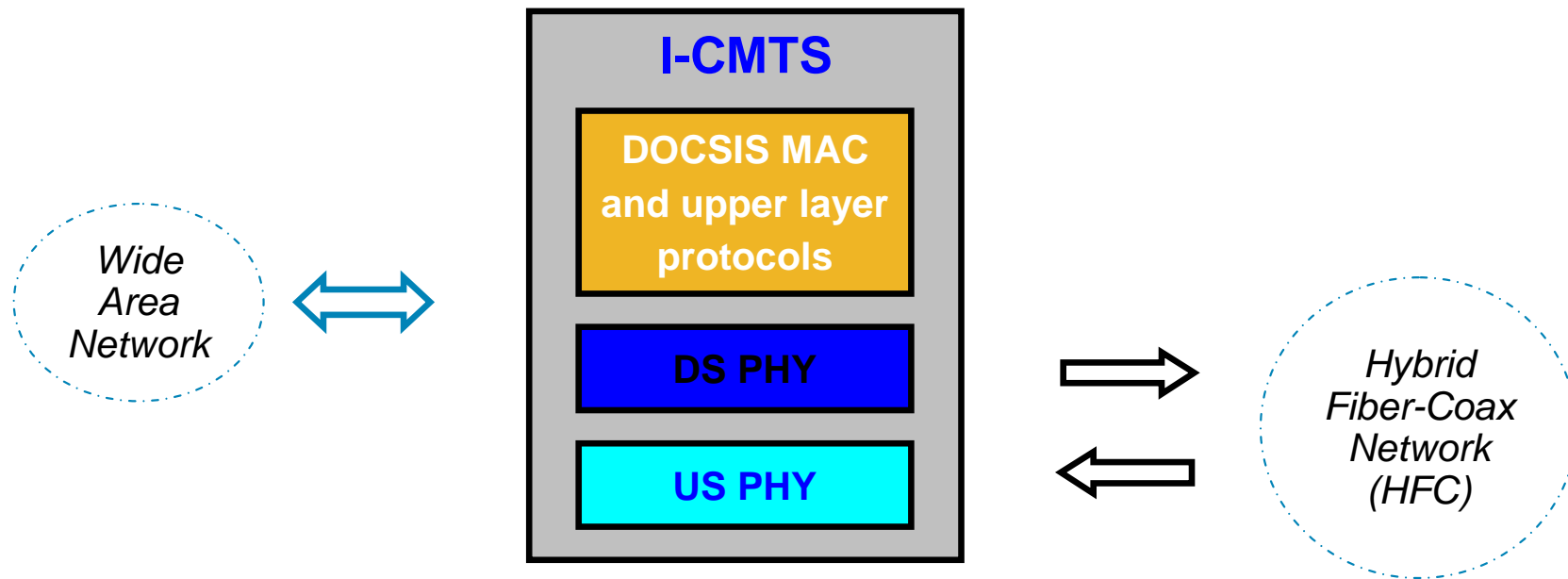

Modular-CMTS Phase 1

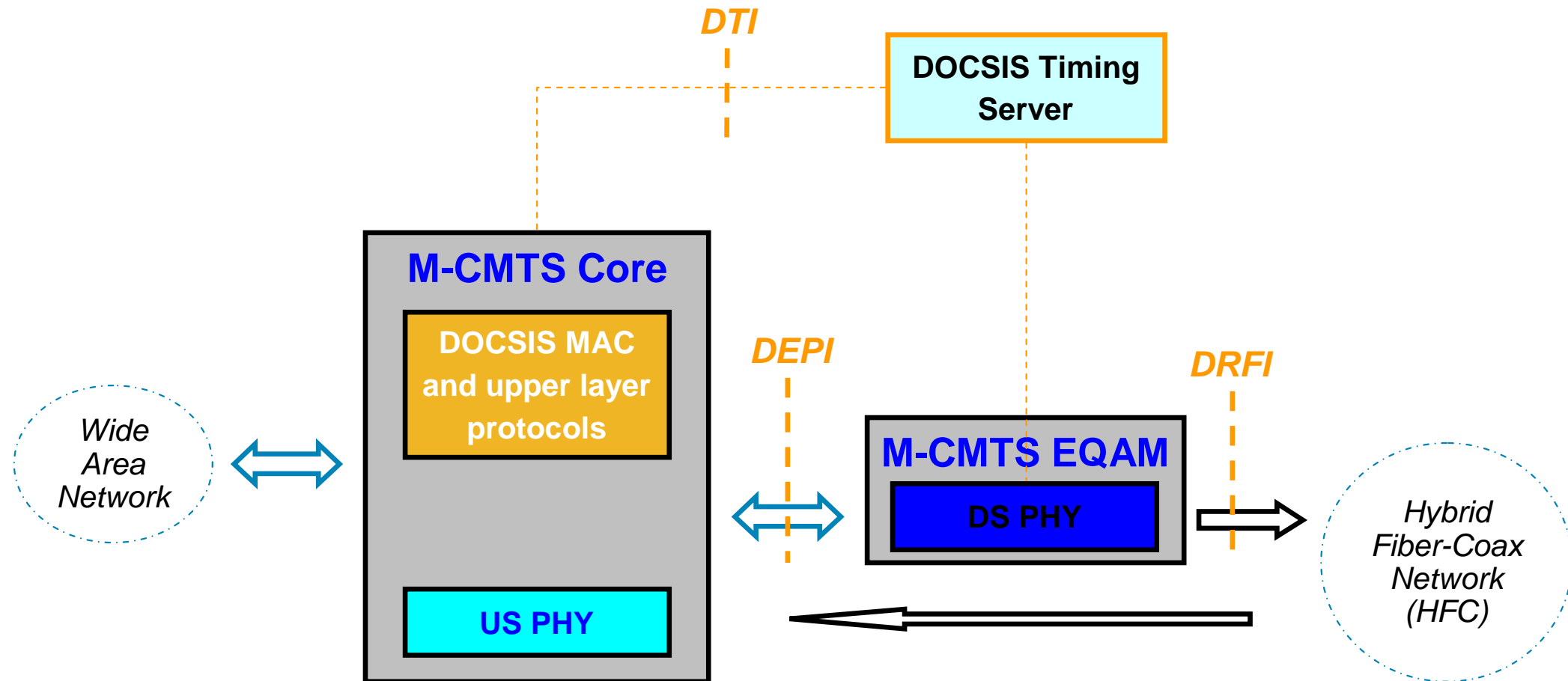

Modular-CMTS Phase 2

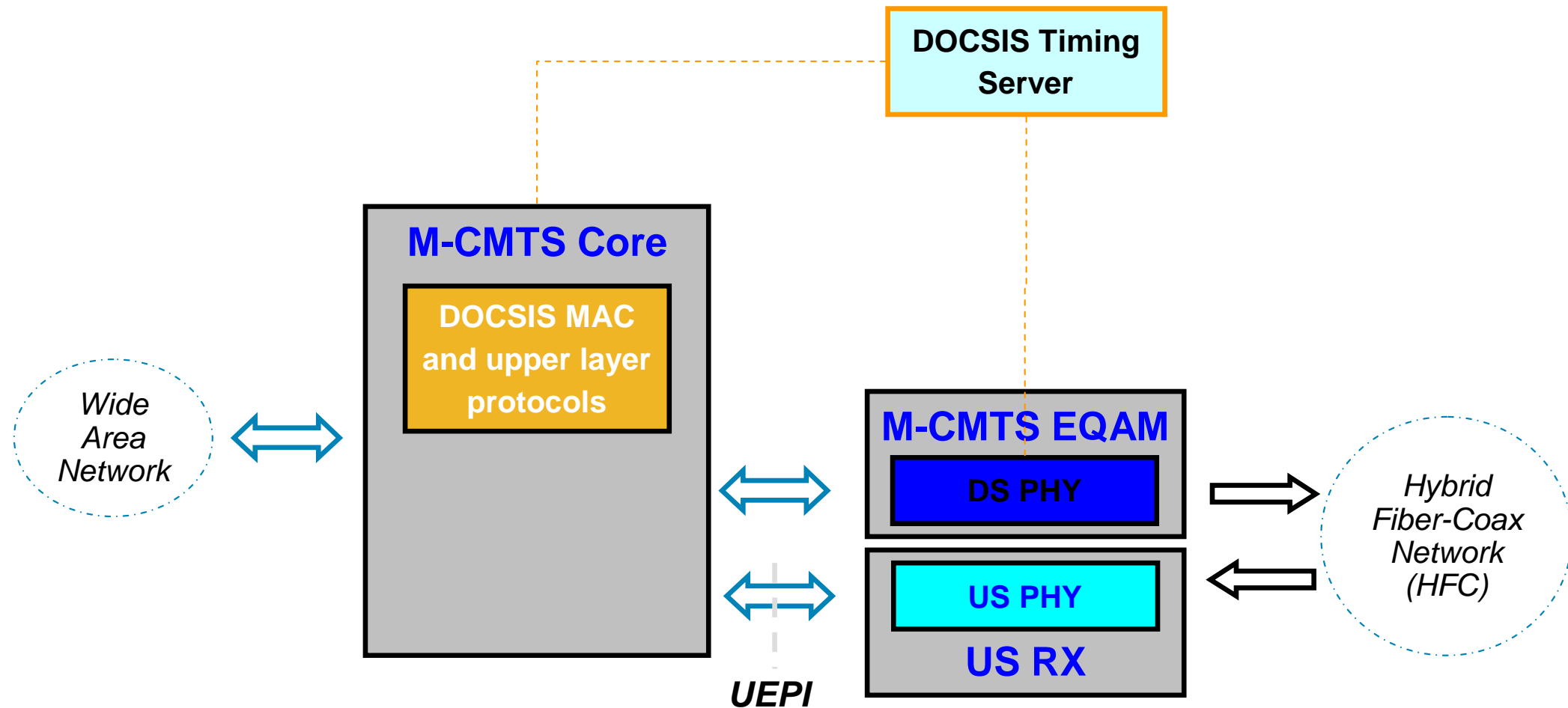

- UEPI: Upstream is an extension to DEPI and is currently under definition at Cisco



M-CMTS Components and Interfaces

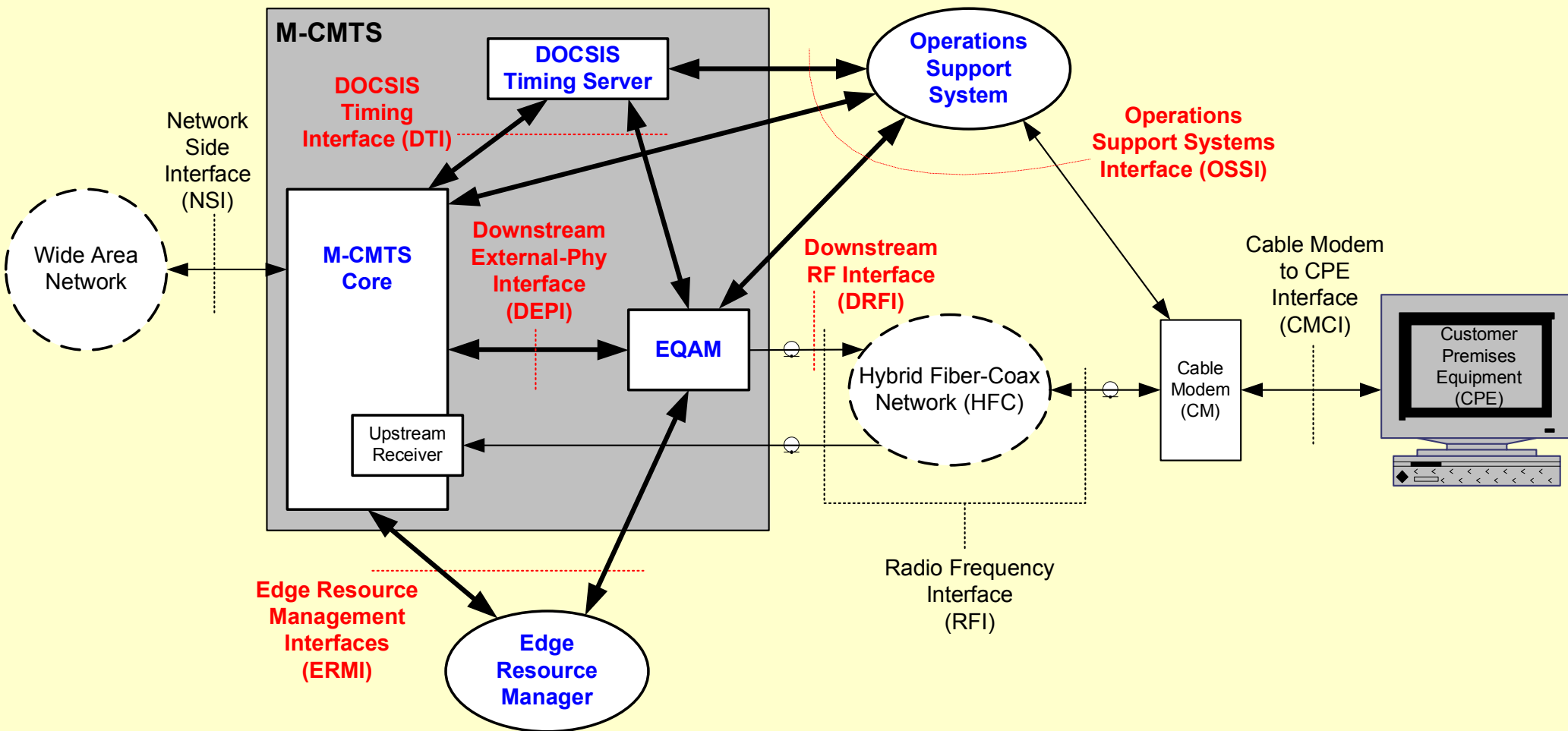

DEPI Intro

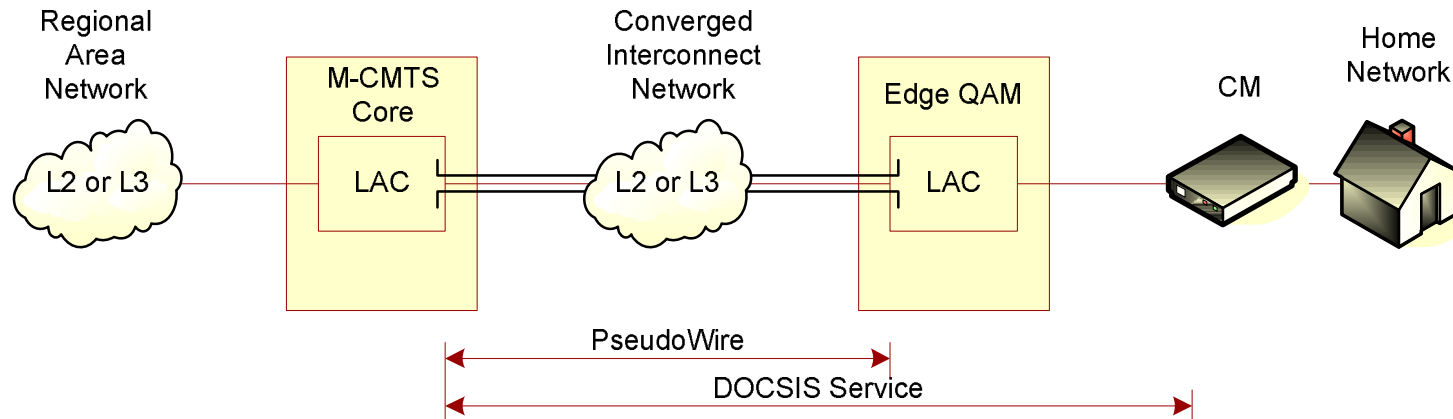

- DEPI is an IP Tunnel, known as a pseudowire, that exists in the downstream direction between the DOCSIS MAC in the M-CMTS Core and the DOCSIS PHY that exists in the EQAM.
- The CIN (Converged Interconnect Network) may be a Layer 2 or Layer 3 network.
- The M-CMTS Core provides the DOCSIS MAC functionality, while the EQAM provides the DOCSIS PHY functionality.
- DEPI interfaces the MAC to the PHY.

DTI: DOCSIS Timing Interface

- A DTI Server supplies a 10.24 MHz frequency plus a DOCSIS timestamp to MAC and PHY
- MAC and PHY contain DTI Clients.
- Two-way protocol. DTI Server cancels out cable and circuit delays.
 - Everyone has the same timestamp.
- Interface is UTP RJ45 Ethernet-like.

Legend

BRG = Baud Rate Generator
TS = Timestamp

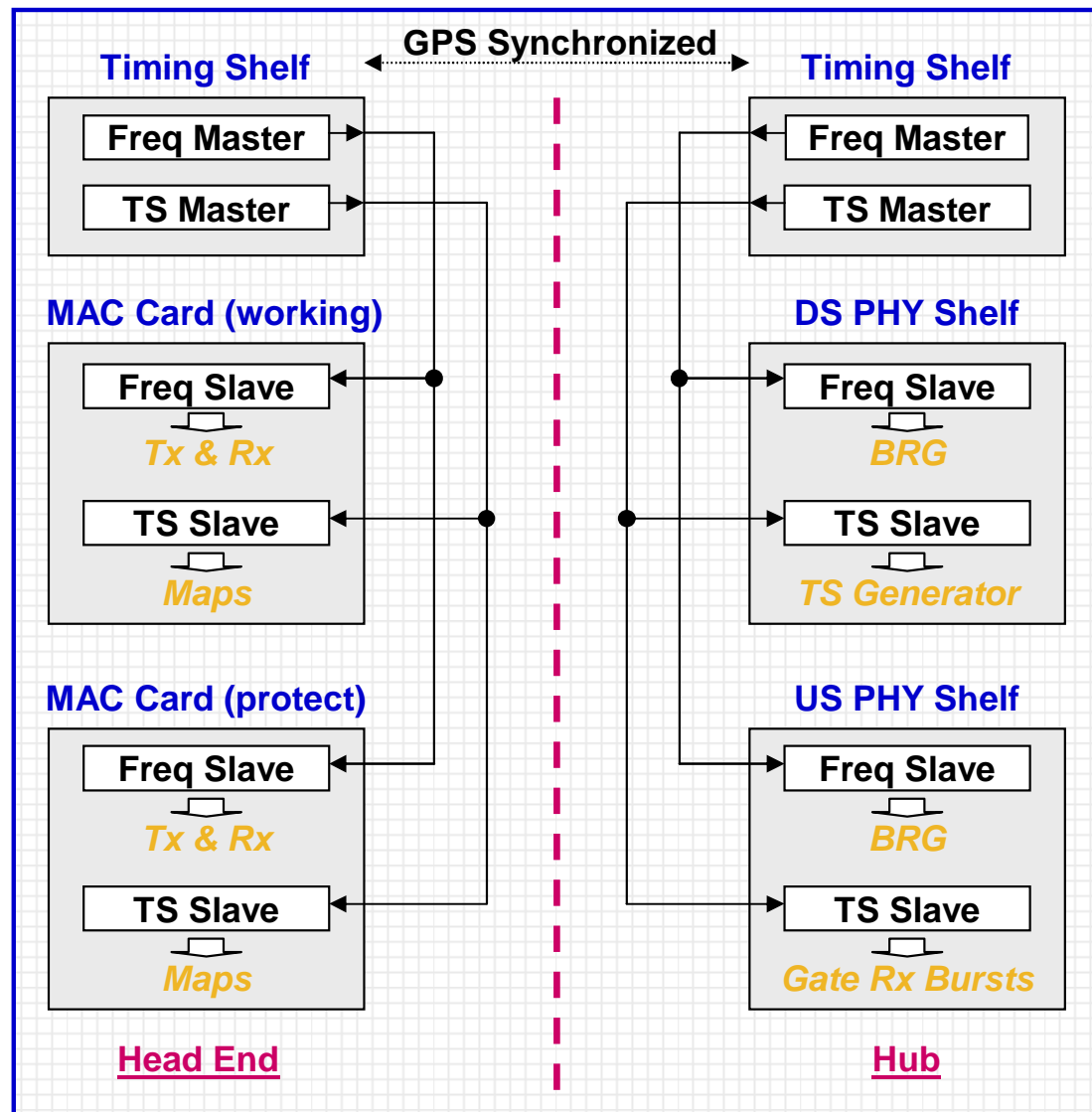

Cisco RF Gateway Family:

U-EQAM Solutions for SDV, VOD, M-CMTS, DOCSIS 3.0 and VDOC

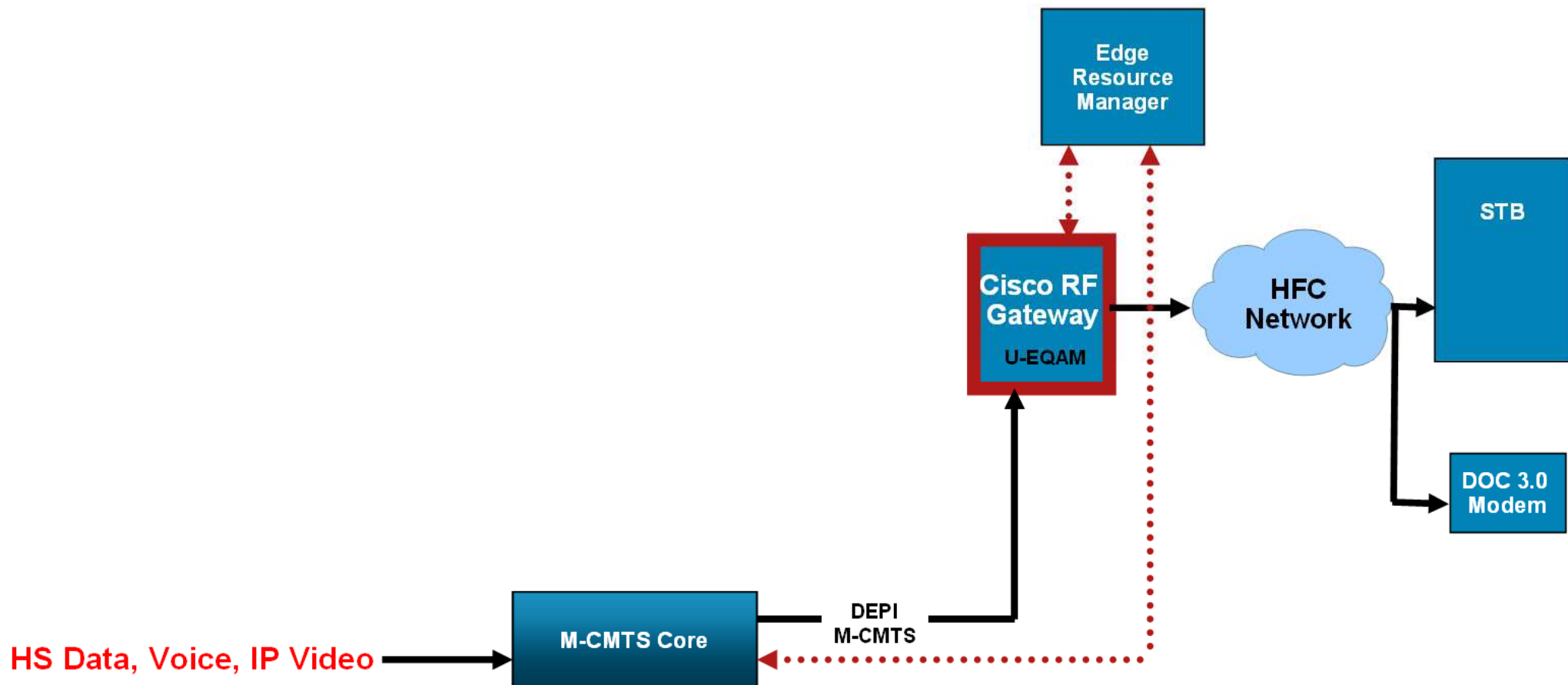

Cisco RF Gateway Family:

U-EQAM Solutions for SDV, VOD, M-CMTS, DOCSIS 3.0 and VDOC

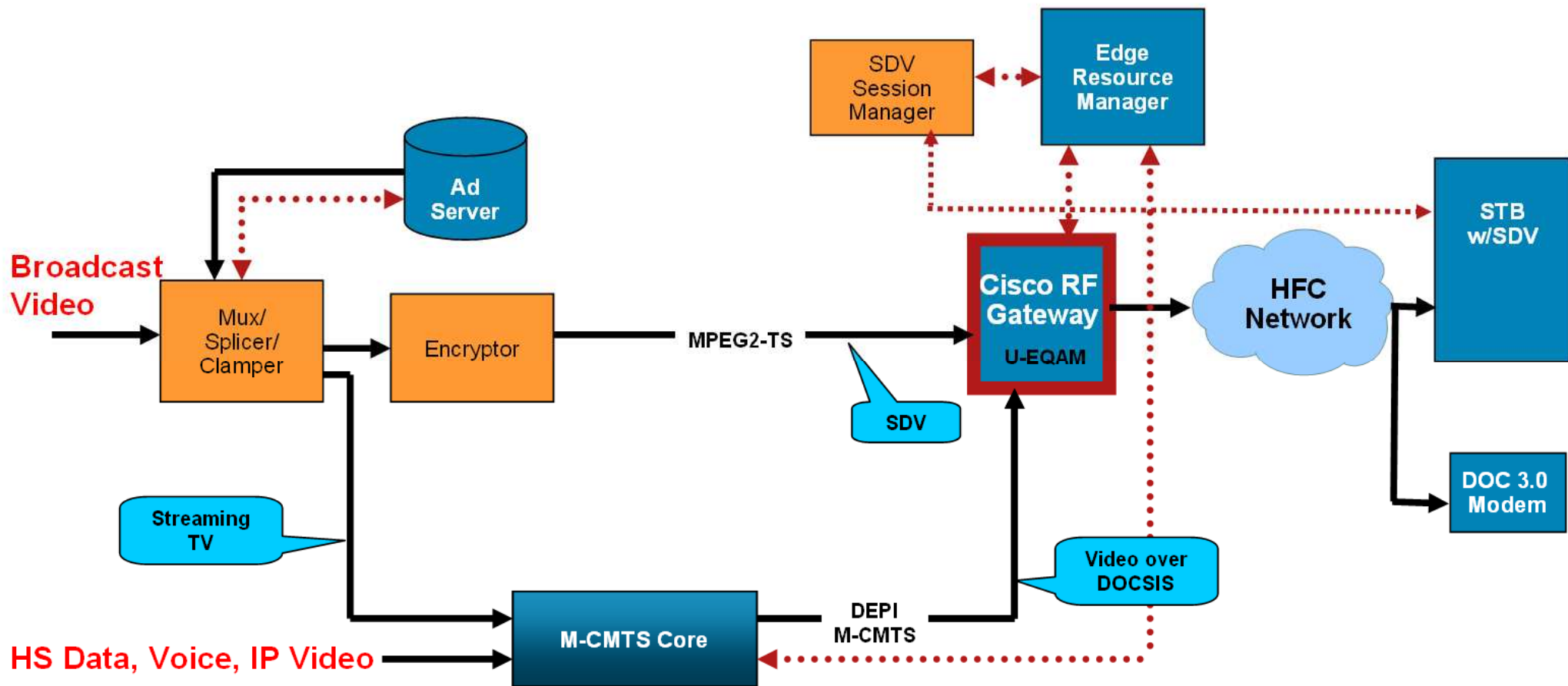

Cisco RF Gateway Family:

U-EQAM Solutions for SDV, VOD, M-CMTS, DOCSIS 3.0 and VDOC

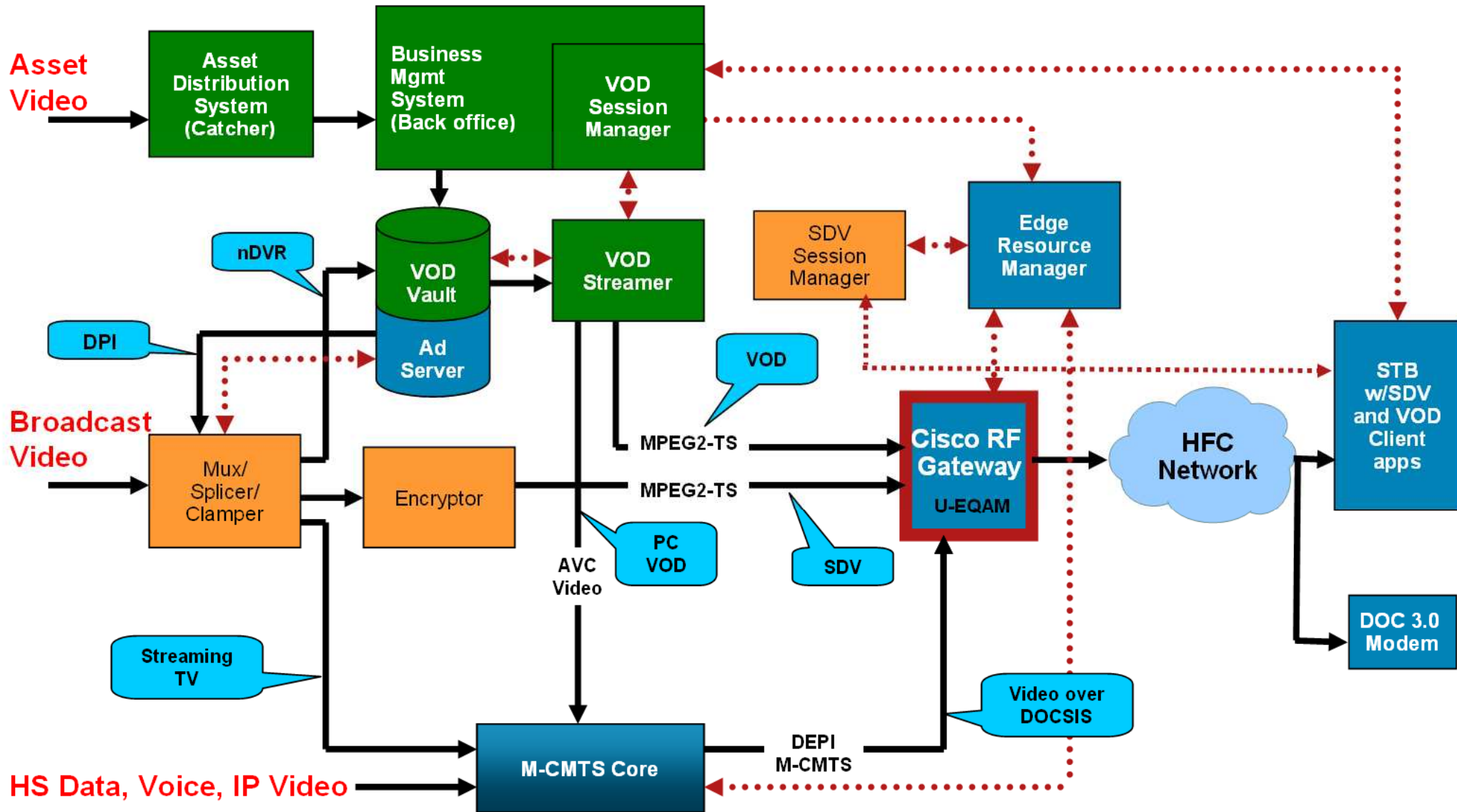

Network Architecture design for Next Generation Services



DOCSIS 3.0 Migration Issues

- Aim to design plant to be **Scalability**, with substantial **Opex** and **Capex savings**
- Flexible solution that enables service to evolve based on operators need and services they plan to offer
- Enables increase of downstream bandwidth to existing subs while enabling DOCSIS 3.0 bonded services
- Minimal Wiring & configurations changes to migrate from one service option to the next
- Provides optimal configuration evolution to provide efficient migration to DOCSIS 3.0
- Leverages both I-CMTS and M-CMTS solutions where appropriate

DOCSIS 3.0 Modelling

- Provide a projection for DS and US spectrum requirement based on service tiers and HHP per node
- Look at plant topology both from and RF and physical standpoint for possible new services
- Provide a projection on possible additional Capex required
- Decide CMTS architecture and possible configuration / grouping of new service tiers

Options	Year 1 50 Mbps	Year 2 75 Mbps	Year 3 100 Mbps	Year 4 125 Mbps
HHP/FN	750	750	750	750
FN per SG	2	2	2	2
HHP/SG	1500	1500	1500	1500
Data Penetration	0.3	0.35	0.38	0.4
DS Concurrency	0.01	0.01	0.01	0.01
US Concurrency	0.04	0.04	0.04	0.04
Basic Tier				
Basic Tier Take Rate(% Customer Base)	15%	15%	15%	15%
Basic Tier DS(Mbps)	5	6	7	10
DS BW needed per Fiber Node(Mbps)	1.69	2.36	2.99	4.50
DS kbps/sub	50000	60000	70000	100000
Basic Tier US(Mbps)	0.768	1.5	2	3
US BW needed Per FN(Mbps)	1.04	2.36	3.42	5.40
US kbps/sub	30720	60000	80000	120000
Standard Tier				
Standard Tier Take Rate	80%	80%	80%	80%
Standard Tier DS(Mbps)	10	15	20	30
DS BW needed per Fiber Node(Mbps)	18.00	31.50	45.60	72.00
DS kbps/sub	100000	150000	200000	300000
Basic Tier US(Mbps)	2	3	10	5
US BW needed Per FN(Mbps)	14.40	25.20	91.20	48.00
US kbps/sub	80000	120000	400000	200000
Premium Tier				
Premium Tier Take Rate	5%	5%	5%	5%
Premium Tier DS(Mbps)	50	75	100	125
DS BW needed per Fiber Node(Mbps)	5.63	9.84	14.25	18.75
DS kbps/sub	500000	750000	1000000	1250000
Premium Tier US(Mbps)	5	6	8	10
US BW needed Per FN(Mbps)	2.25	3.15	4.56	6.00
US kbps/sub	200000	240000	320000	400000
VOIP				
Rate(kbps)	0.120	0.120	0.120	0.120
CCS-Oversubscription	5	5	5	5
% Customer Base	0.242	0.3	0.3	0.3
Total BW Per Node	4.356	5.400	5.400	5.400
Total BW Per Node				
DS	29.67	49.11	68.24	100.65
US	22.04	36.11	104.58	64.80
Number of Channels/FN for non-Bonded				
DS	0.769	1.272	1.768	2.608
US	1.20	1.96	5.67	3.52
Number of Channels/FN for Bonded				
DS	1.65	2.30	2.94	3.59
US	0	0	0	0
Total Channels Per FN				
DS	3.00	4.00	5.00	7.00
US	2.00	2.00	6.00	4.00

Example Initial Configuration

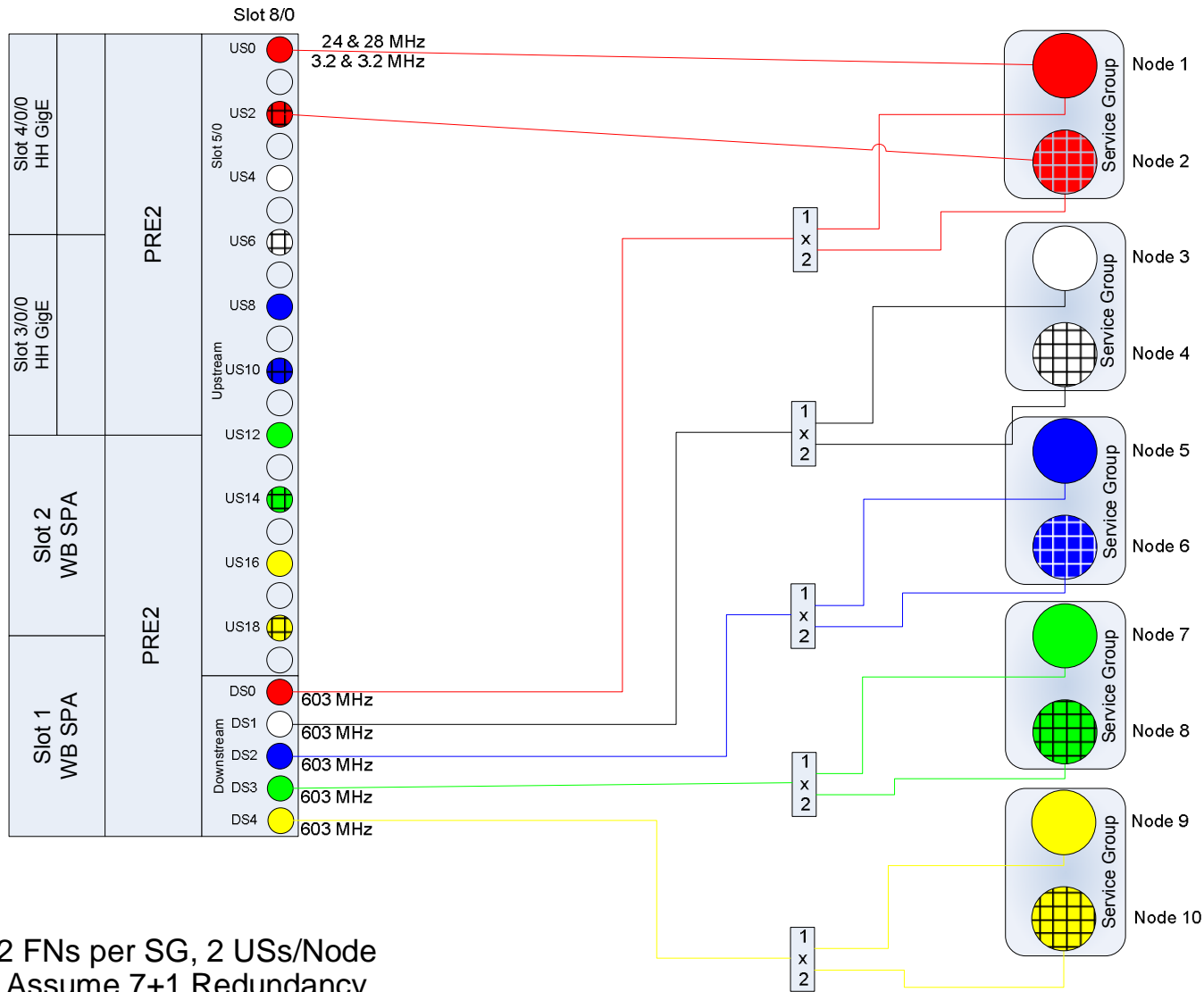

2 FNs per SG, 2 USs/Node
Assume 7+1 Redundancy

HHP and penetration depends on service/tier mix

Example Initial Configuration (using MC5x20)

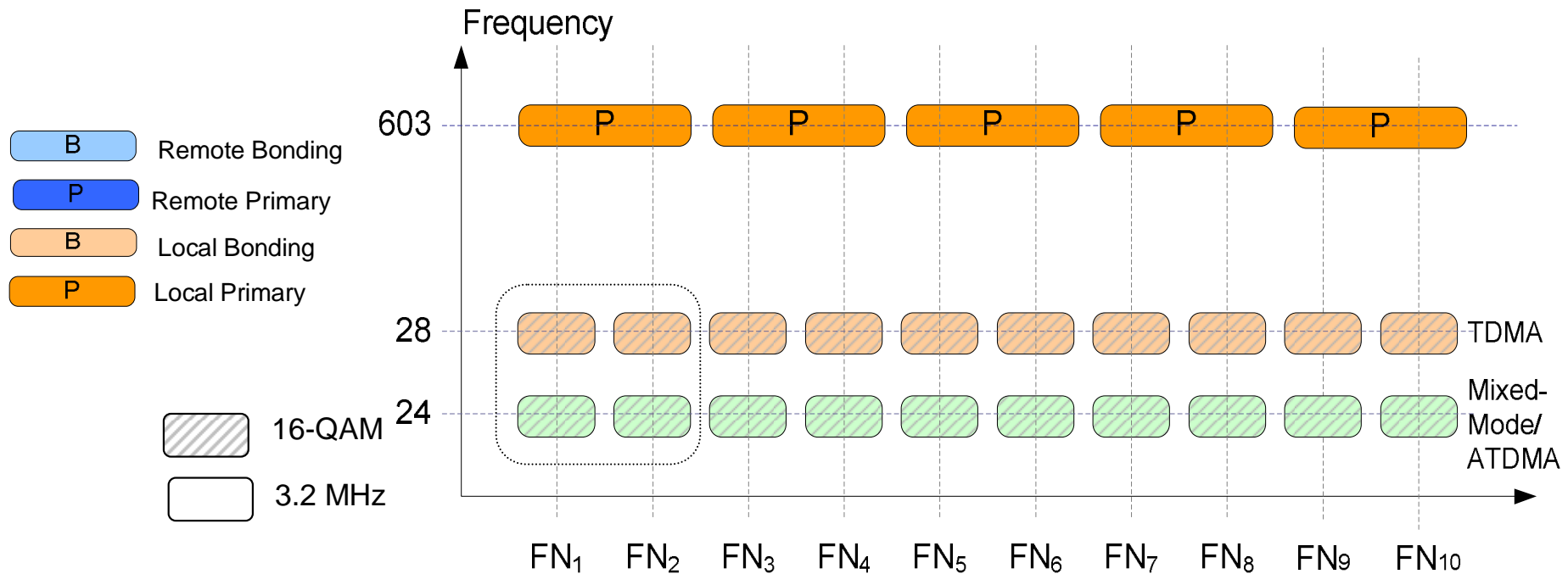

- 5, 1x4 MAC domains with 256-QAM DS & 3.2 MHz, 16-QAM US
- 2 fiber node service groups (SG) with US load balance
- 7+1 linecard redundancy
- 70 US nodes covered by 10K chassis (35 SGs)

Example Service Templates

- Option 1: 50 Mbps bonded service
- Option 2: 100 Mbps bonded service
- Option 3: 100 Mbps DS and 50 Mbps US bonded service
- Option 4a: 150+ Mbps DS and US data service with additional 150+ Mbps bonded service for VDOC
- Option 5b: 200 + Mbps DS and US data service with additional 200+ Mbps bonded service for VDOC

Option 1: 50 Mbps DS Service

- 50 Mbps high-end tier will require 3 DS carriers
- Provides one MC520 DS and a maximum of 4 DS carriers from the RFGW
- Maximum flexibility that allows high peak bonded rate while allowing load balancing of D1.x/D2.0 CMs
- Minimal wiring requirements
 - Enables future DS growth with no wiring change
- Reduces node splits and de-combines

Option 2: 100 Mbps Service

- Enables 100 Mbps service with 4 DS carriers
- No wiring change – enable 2 additional chs on EQAM
- Provides one MC520 DS and a maximum of 4 DS carriers from the RFGW
 - Maximum bonded speed of 160 Mbps without wiring change
- Maximum flexibility that allows high peak bonded rate of 120 Mbps while allowing load balancing of D1.x/D2.0 CMs
- Minimal wiring requirements
 - Enables future DS growth with no wiring change
- Reduces node splits and de-combines

Option 2: 100 Mbps Service

- 5 DS freqs
- 2 US freqs

- B Remote Bonding
- P Remote Primary
- B Local Bonding
- P Local Primary

- ▨ 16-QAM
- ▩ 64-QAM
- 3.2 MHz
- 6.4 MHz

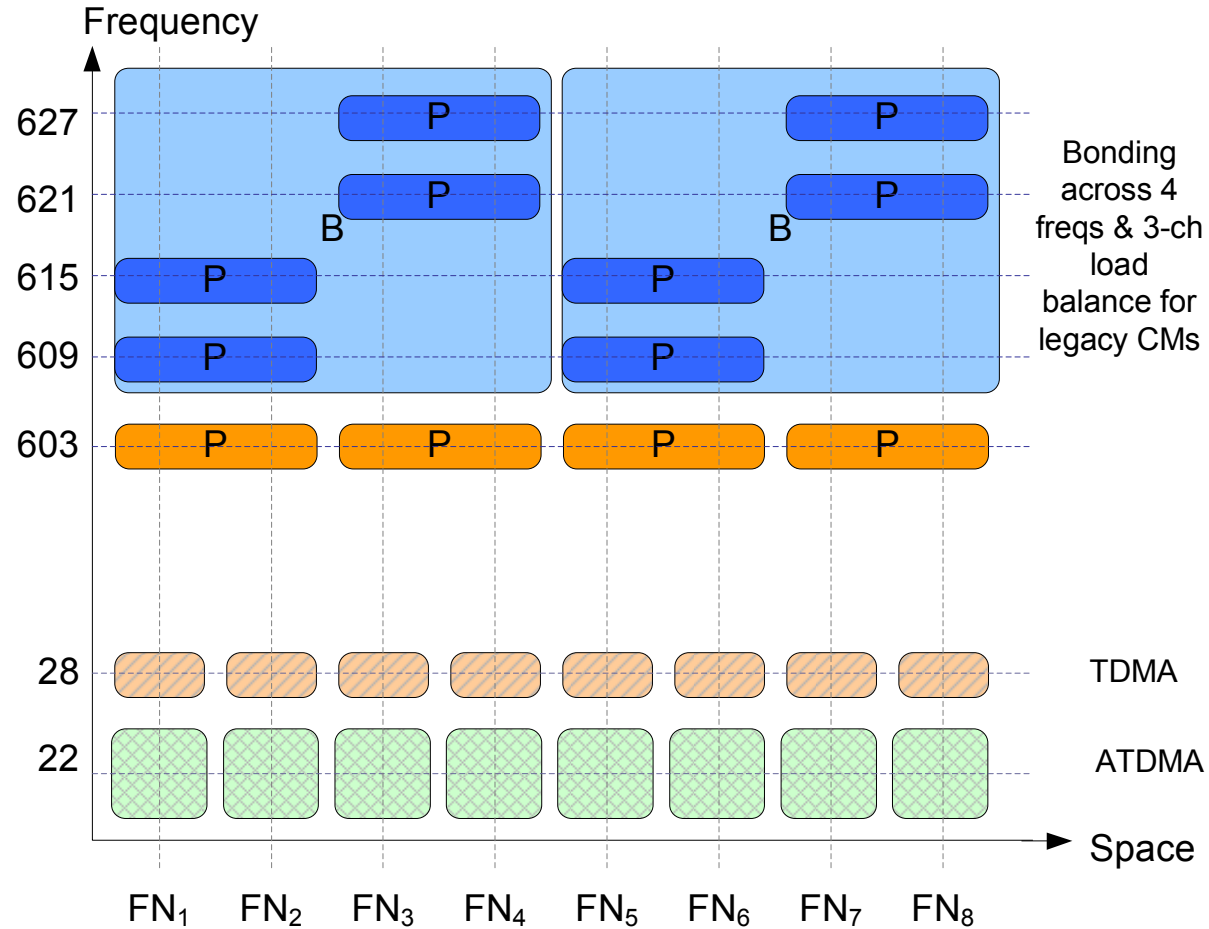

- 4, 3x4 MAC domains with ATDMA & TDMA USs

Option 3: 100 Mbps DS & 50+ Mbps US Service

- Extends 100 Mbps service with 4 DS carriers
- Enables 50+Mbps bonded US service with US carriers
- Minimizes wiring change

Option 3: 100+ Mbps Tier & Channel US Bonding (Step 1)

- 5 DS freqs
- 2 US freqs

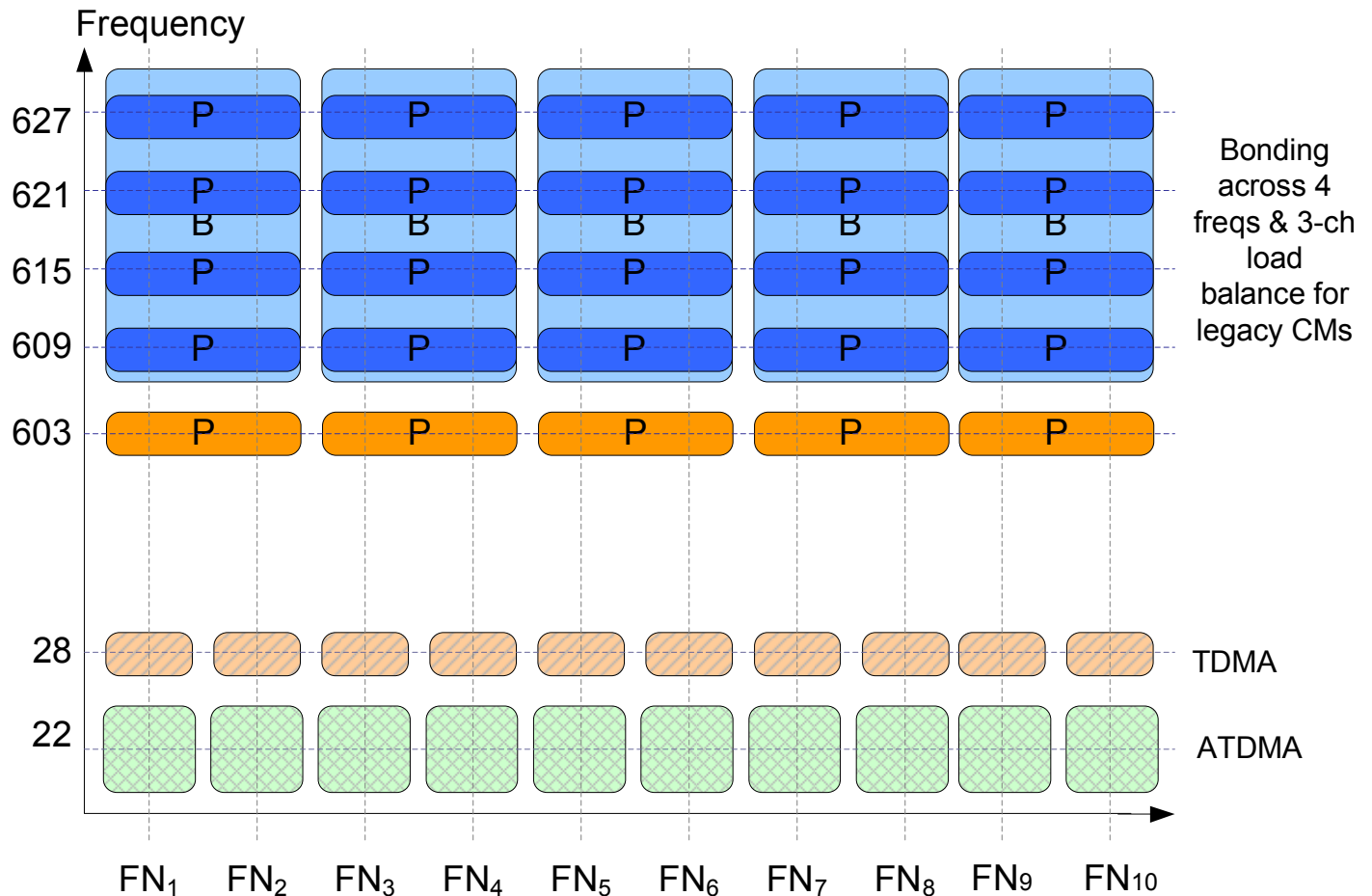
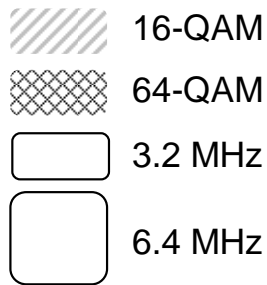
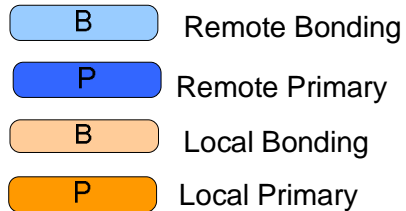

- 5, 5x4 MAC domains with ATDMA & TDMA USs

Option 3: 100+ Mbps Tier & Channel US Bonding (Step 2)

- 5 DS freqs
- 4 US freqs

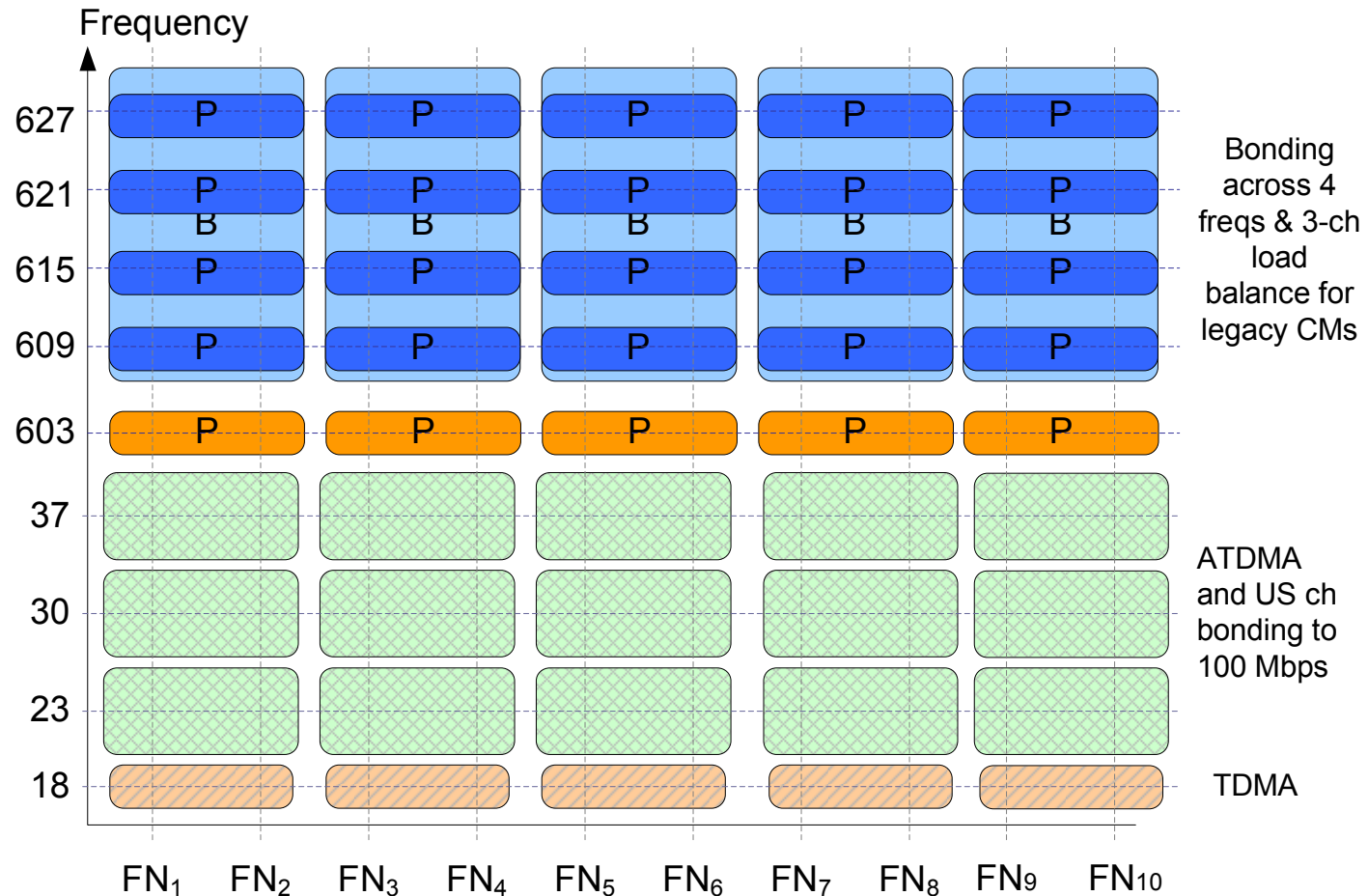
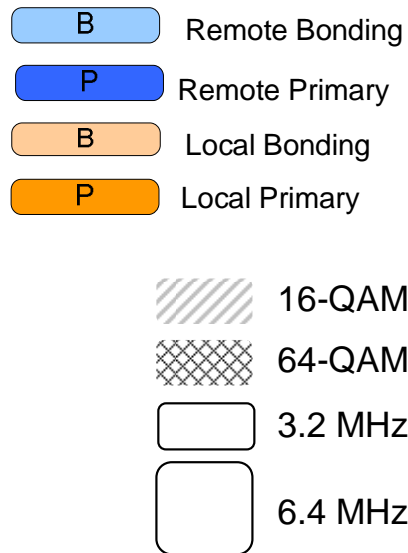

- 5, 5x4 MAC domains with ATDMA & TDMA USs
- Enable US channel Bonding across 2 FN

Option 4: 150+ Mbps Symmetrical HSD & VDOC

- Provides 150+ symmetrical bonded service
- Ideal for high bandwidth IP video solution over DOCSIS
- Place VDOC channels on Modular DS channels
- Maintain data service on integrated DS channels
- Highly flexible and scalable solution

Option 4a: 150+ with HSD & VDOC – ICMTS Based

- 8 DS freqs
- 4 US freqs

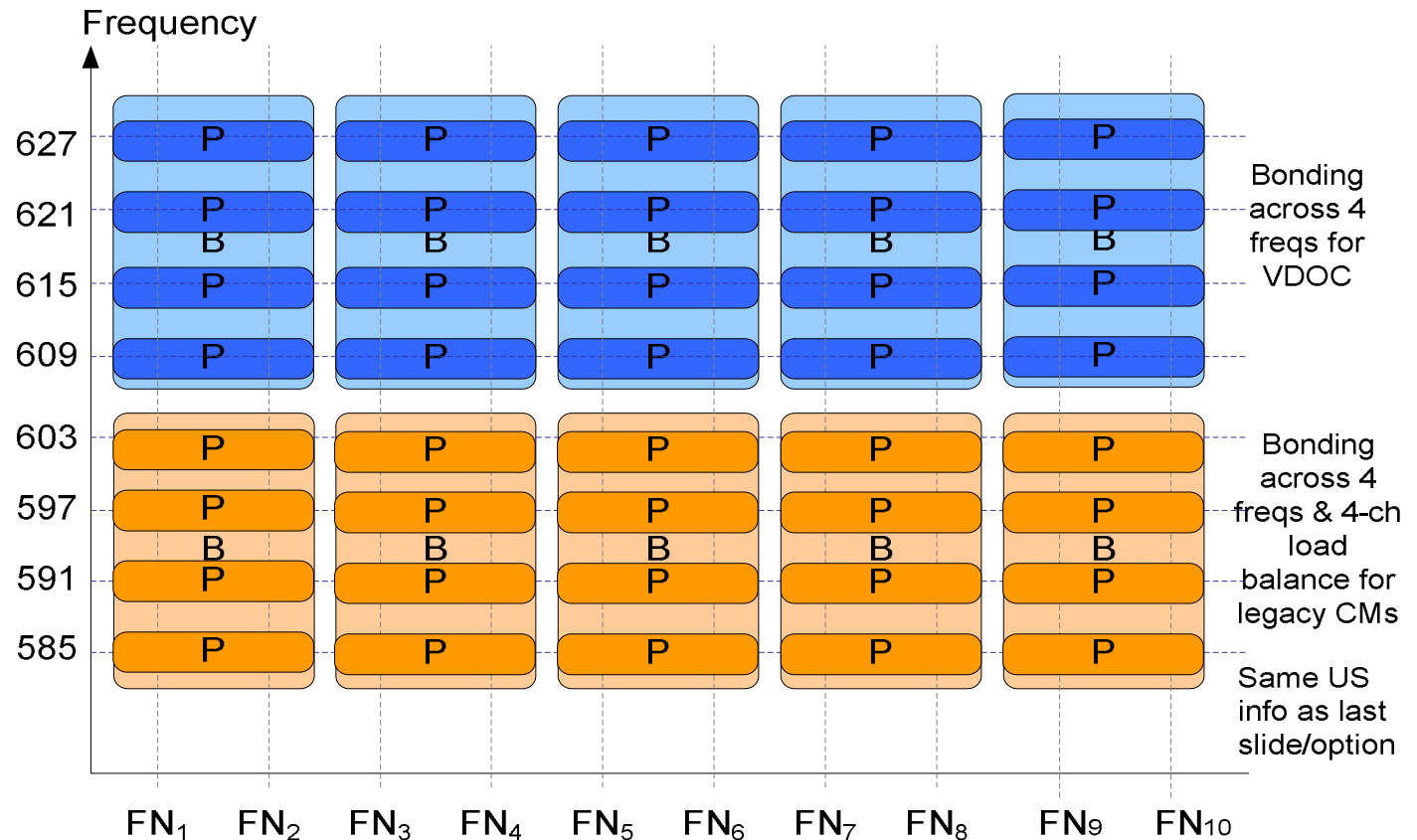
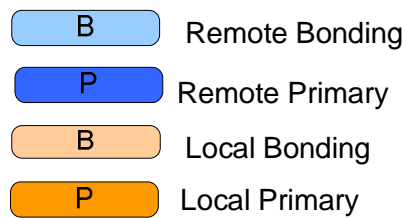

- 5, 8x4 MAC domains with ATDMA & TDMA USs
- 2, 4-ch bonding groups using existing SPA and MC20x20 cards
- Requires LC swap, RF wiring remains the same

Option 4b: 150+ with HSD & VDOC – MCMTS Based

- Provides 200+ symmetrical bonded service
- The ultimate Modular solution
- Highly flexible and scalable solution
- Massive amount of bandwidth ideal for large scale unicast and broadcast IP video delivery
- Using the MC3G60 linecard

Option 4b: VDOC & HSD, MC3G60

- 8 DS freqs
- 6 US freqs

P Remote DS

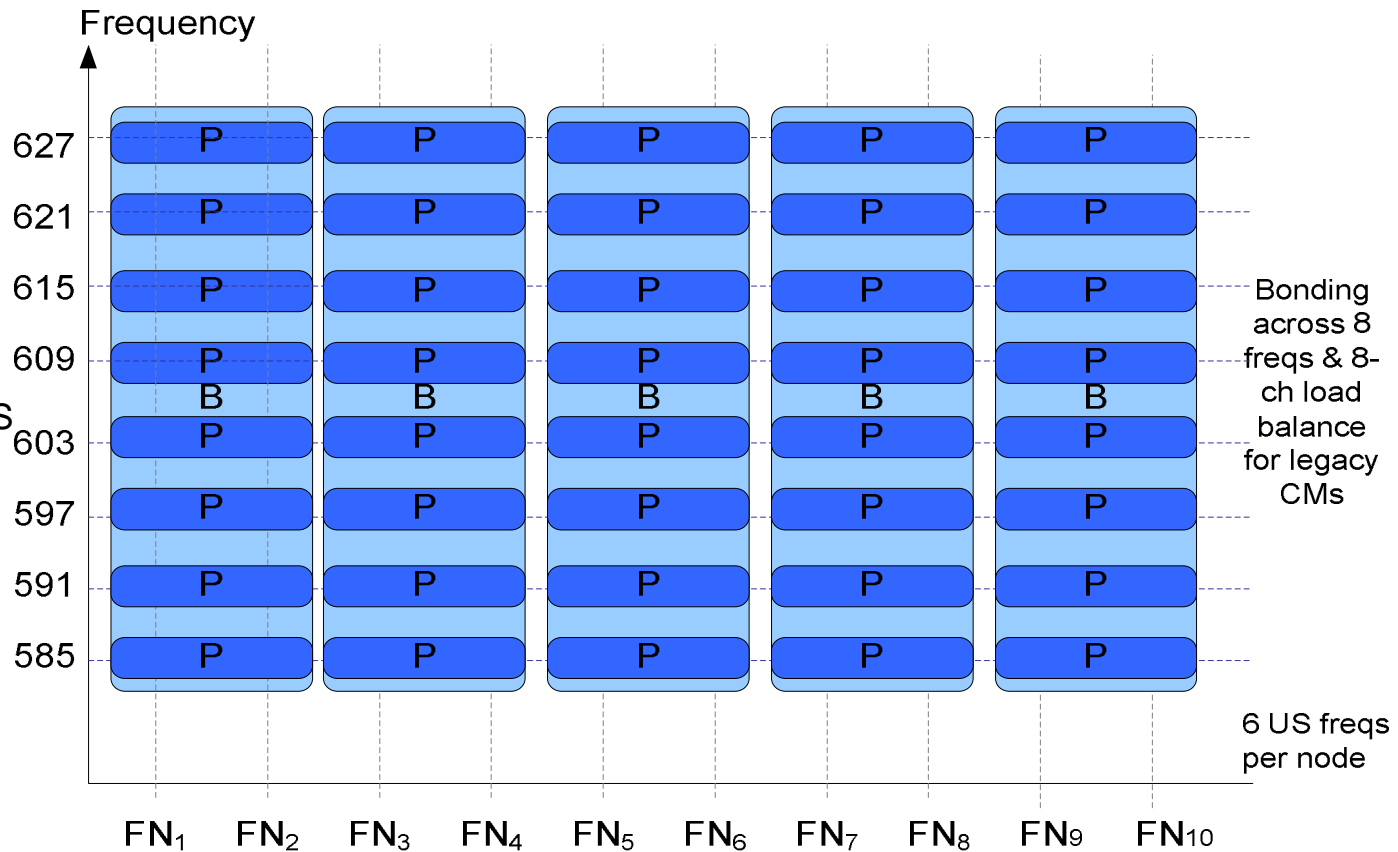

- 5, 8x12 MAC domains with ATDMA & TDMA USs
- 1, 8-ch bonding group (no SPAs required)
- Possible to use RFGW-10 for ease of wiring

Summary

- M-CMTS is an architecture that is currently being deployed
Separation was done between MAC and PHY.
- M-CMTS, when combined with Cisco's DOCSIS 3.0 Channel Bonding architecture for DOCSIS will provide:
 - significantly more flexibility in configuration
 - significantly lower transport cost per bit
 - significantly higher data capacities than anything out there today.
- DOCSIS 3.0 will provide an extremely secure, flexible and cost effective solution for cable MSO's in the coming years to deploy triple play services over existing CATV infrastructure.
- The saying '10x the bandwidth at 1/10 the cost' is a REALITY !!

Meet The Expert

To make the most of your time at Cisco Networkers 2009, schedule a Face-to-Face Meeting with a top Cisco Expert.

Designed to provide a "big picture" perspective as well as "in-depth" technology discussions, these face-to-face meetings will provide fascinating dialogue and a wealth of valuable insights and ideas.

Visit the Meeting Centre reception desk located in the Meeting Centre in World of Solutions

Recommended Reading

BRKBBA-2005

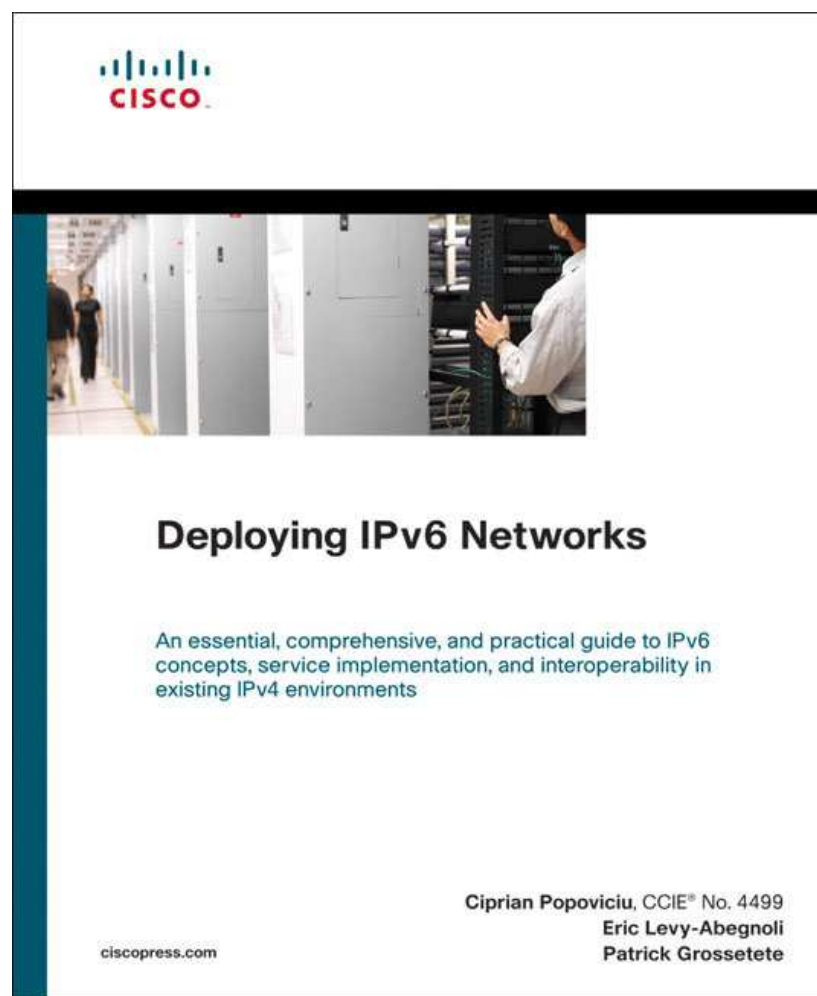
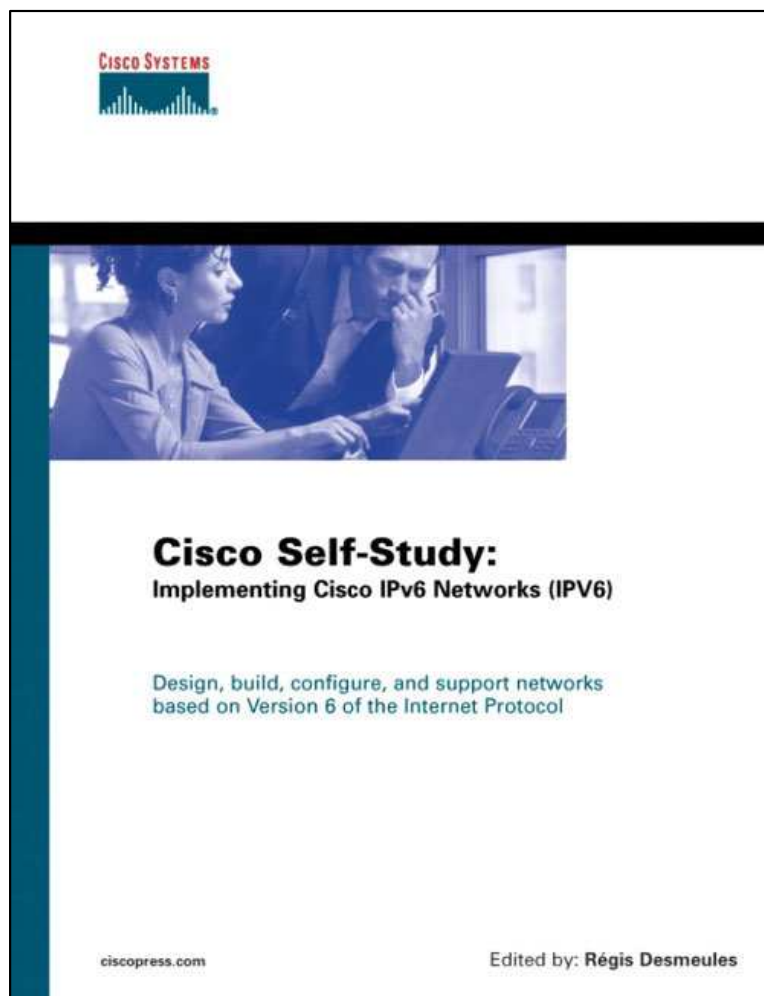

Source: Cisco Press

Q and A



