

CABLE-TEC EXPO® 2018

# VISION OF THE FUTURE

SCTE • ISBE



ATLANTA, GA  
OCTOBER 22-25





# Learnings From a DAA/DOCSIS 3.1 Early Adopter: Launching and Maintaining a Next-Gen HFC Plant

**David Hering**  
Senior Product Line Manager  
VIAVI Solutions

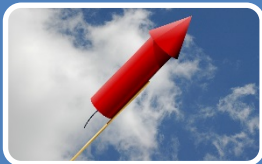

## Unprecedented Broadband Demand Growth

- Driving explosive node count growth



## Traditional Node Splits Can't Keep Up

- Cost, hub power/cooling/rack space constraints

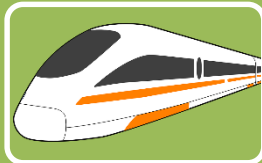

## DOCSIS 3.1 Has Arrived!

- 4096QAM+ possible, but SNR still matters



## 5G Wireless and FDX DOCSIS Are Coming

- Great Wires Make Great Wireless

## Old Tricks For Bandwidth Expansion No Longer Work

 **More Carriers**

 **More Bits/Hz**

 **Split Nodes**

# The Solution: Distributed Access Architectures

## Centralized Access Architecture (Legacy)

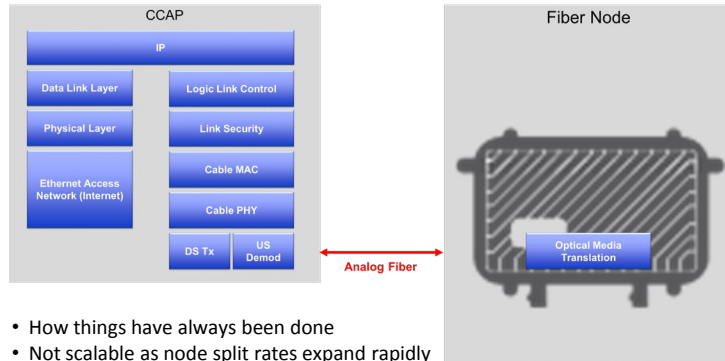

- How things have always been done
- Not scalable as node split rates expand rapidly
- Will remain majority of nodes worldwide for many years

## Remote PHY

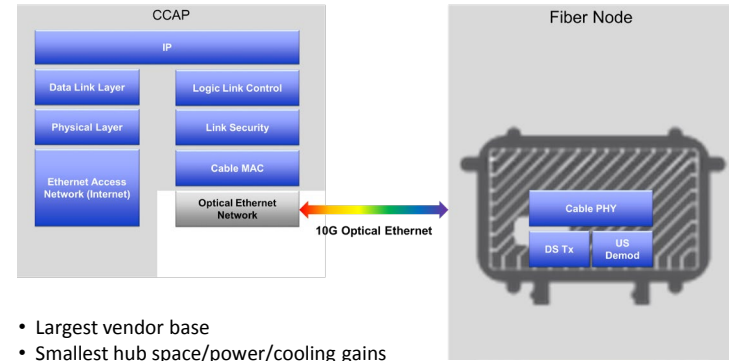

- Largest vendor base
- Smallest hub space/power/cooling gains
- Keeps most complex portions centralized

## Remote MACPHY

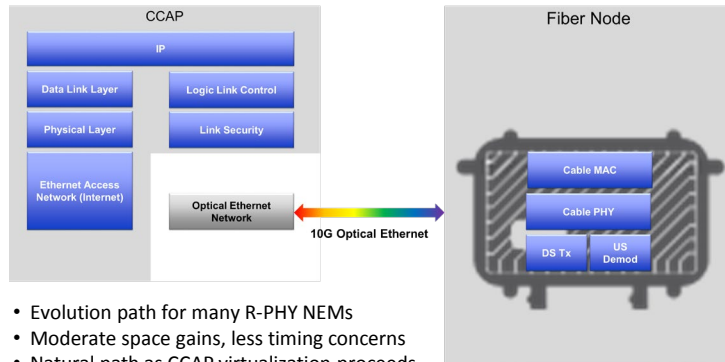

- Evolution path for many R-PHY NEMs
- Moderate space gains, less timing concerns
- Natural path as CCAP virtualization proceeds

## Remote CCAP

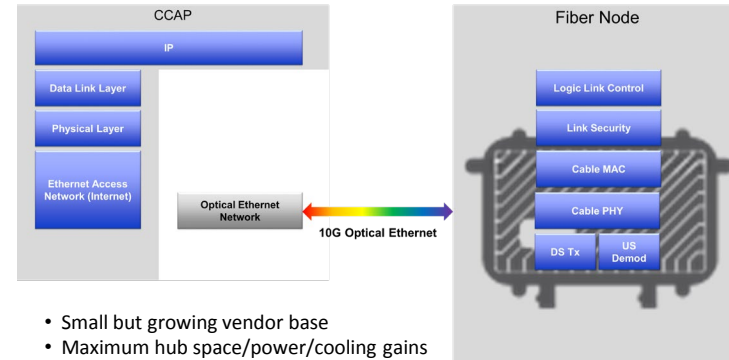

- Small but growing vendor base
- Maximum hub space/power/cooling gains
- Most self-contained

## Many Other Benefits

### Deeper Ethernet Enables Flexibility

- Split off FTTH as needed
- Simplify 5G backhaul, Biz Svc

### More Robust Network

- Less fidgety optical link
- Higher optical link SNR/greater distances

### Enabler For The Future

- Simplifies FDX, enables fiber-deep

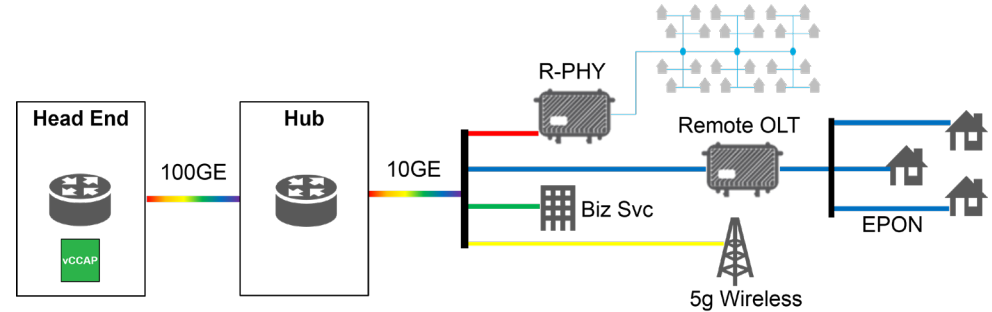

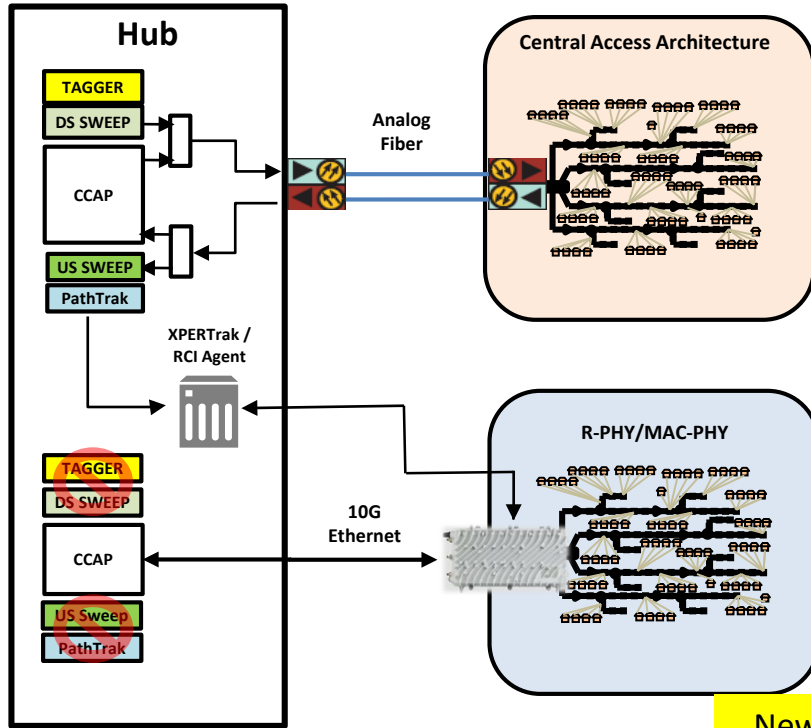

## Today's Hub:

- Return RF Feed For Upstream Tools
- Downstream Sweep RF Injection Point



## DAA Impact:

- No Return RF In Hub
- No Downstream RF Injection Point
- Can't Use Existing Headend HW



New Approaches are Needed for Ingress Suppression, Sweep and Leakage Detection!

## New Interface Created:

### Redistribution Creates New Interface

- New testing needed
- Organizational demarks disrupted
- Confusion, finger pointing likely

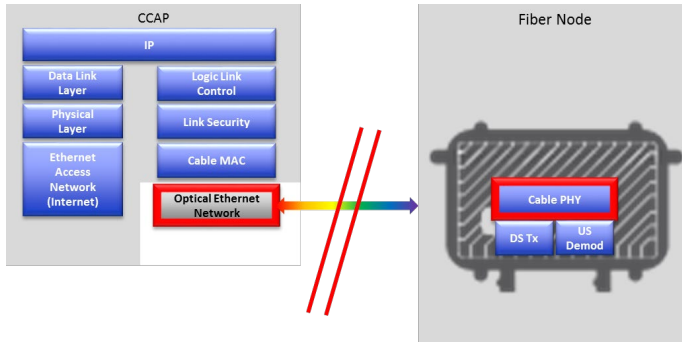

## Other Challenges:

### More/Deeper Fiber, Ethernet

- No longer just for specialists
- Lots more folks need tools/training

### Plant Proliferation/Complexity

- Mix of architectures, vendors
- Process standardization challenging

### Exponential Node Count Growth

- Too many nodes, too little time
- Must focus on nodes with most critical issues first

# PTP Use in Remote PHY

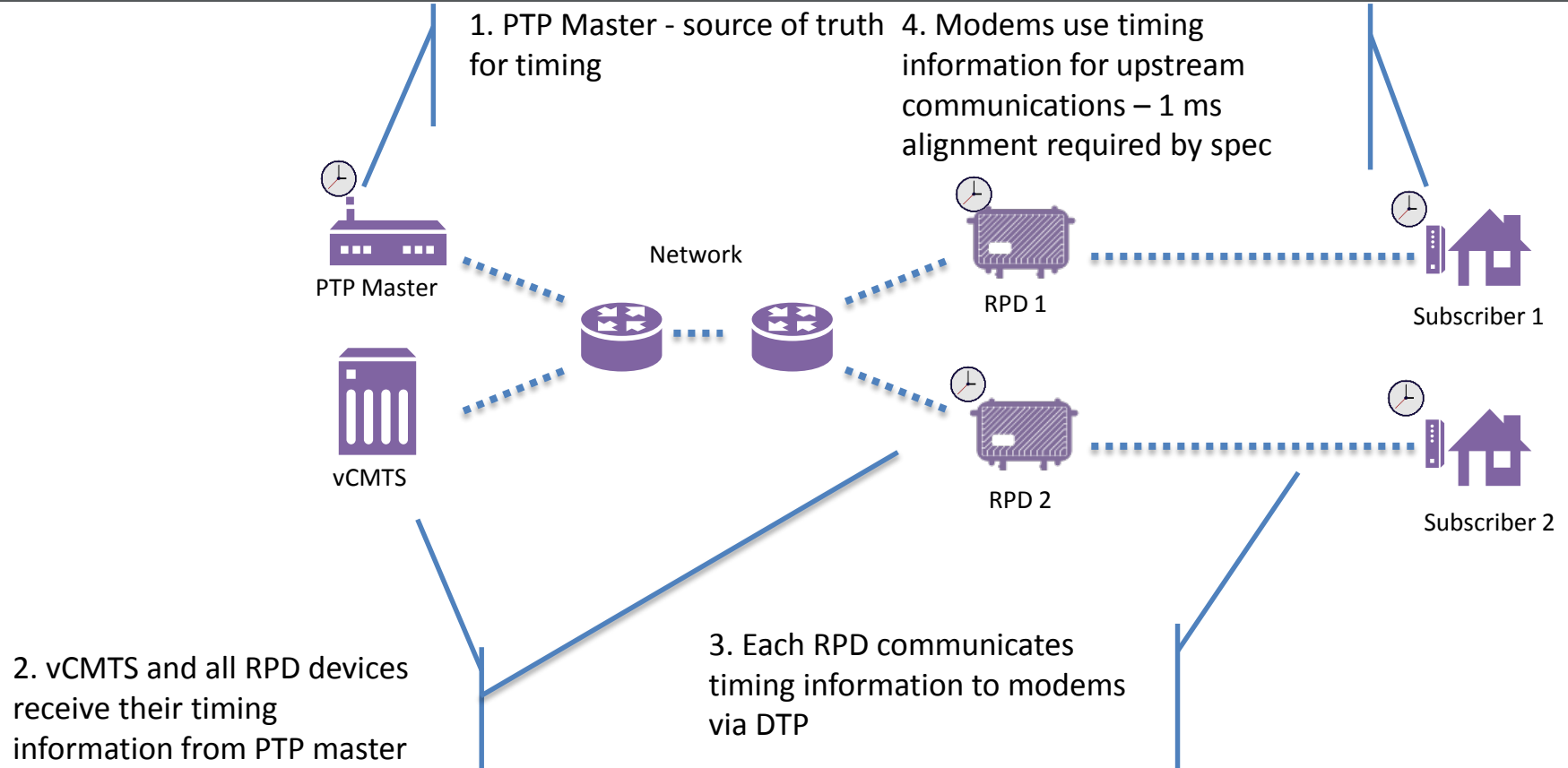

# Risks of Not Testing PTP in DAA

## Downstream Congestion Causes Upstream BER

### Challenges: PTP Timing

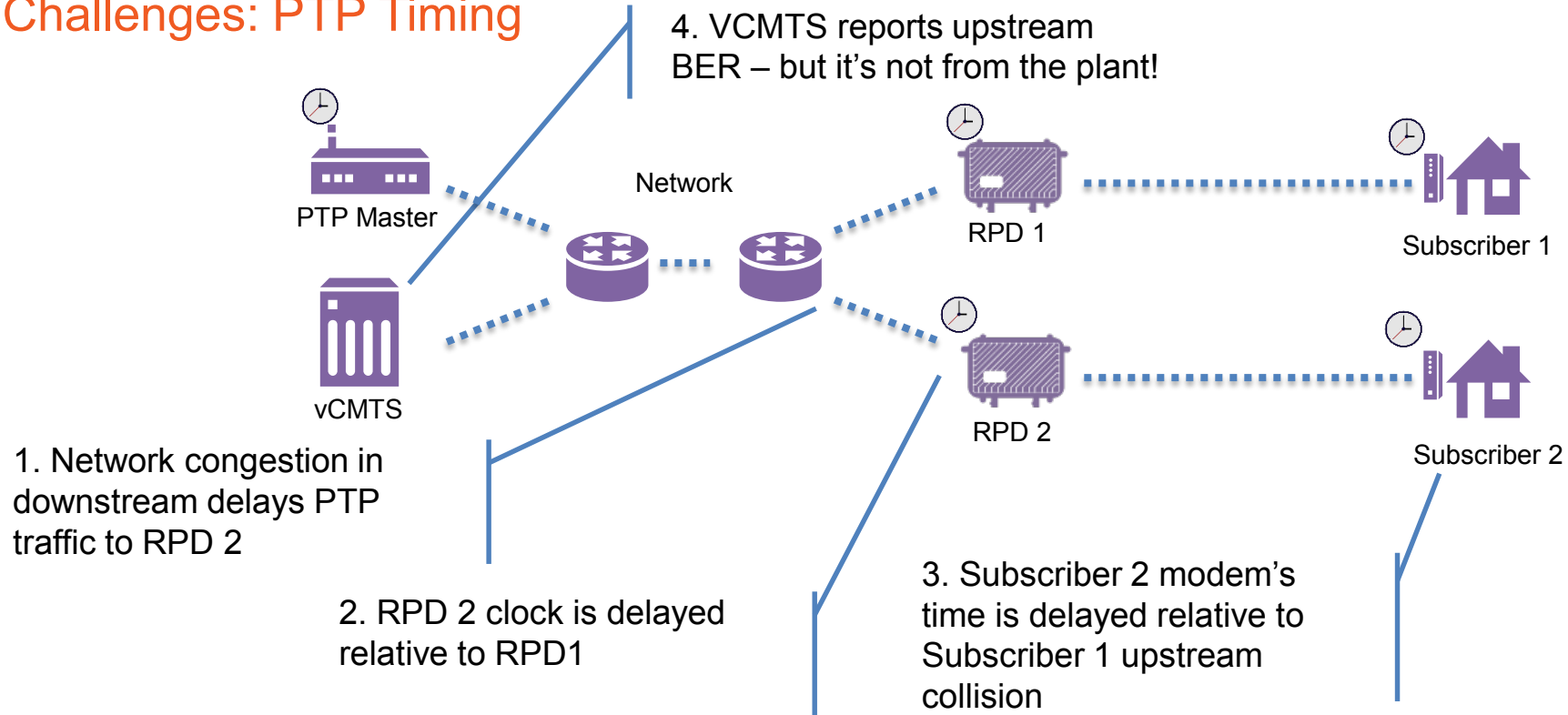

# Risks of Not Testing PTP in DAA

## Downstream Congestion Causes Upstream BER

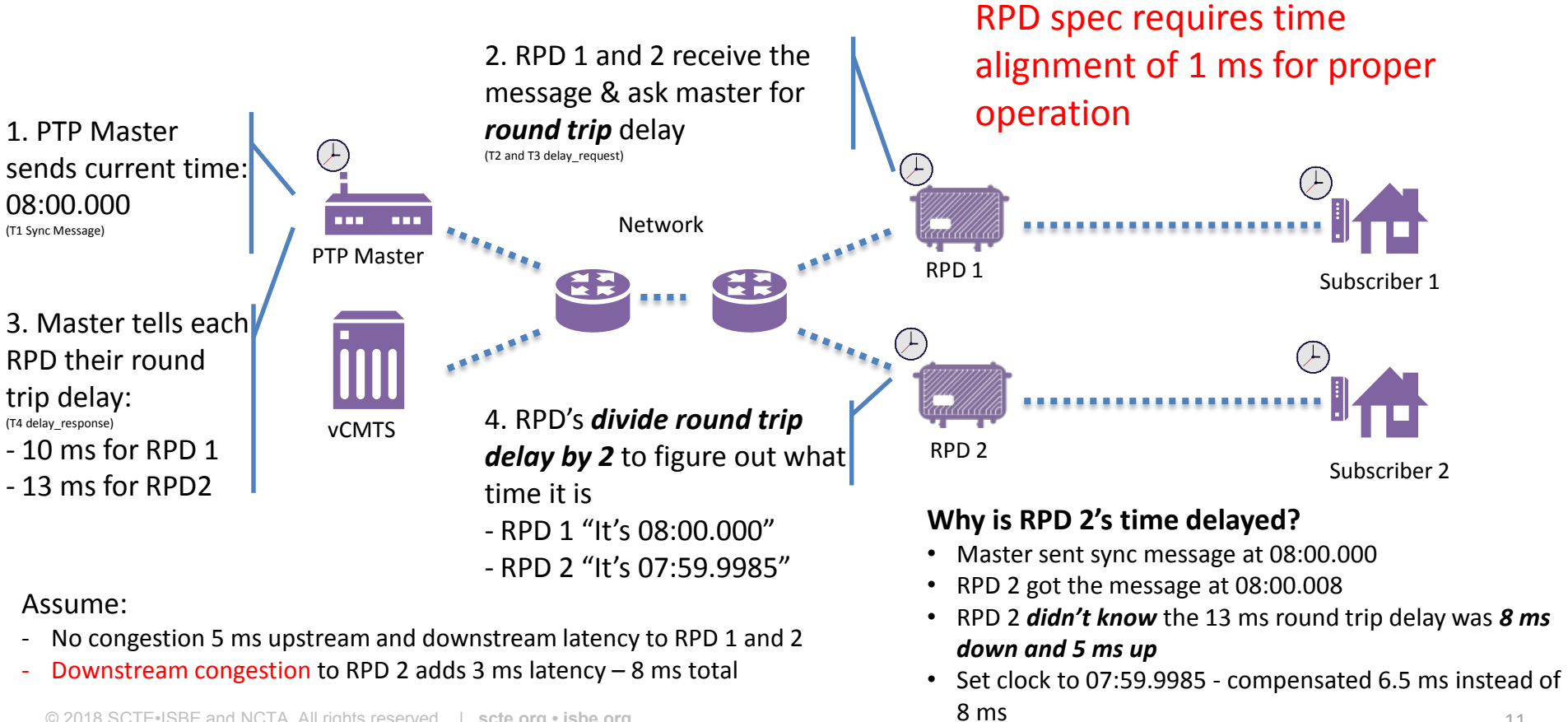

# DAA Transition Impacts Almost All Aspects of Maint & Test

## Fiber Monitoring



## Metro/Ethernet



## HFC Monitoring/QoE



## Plant Leakage

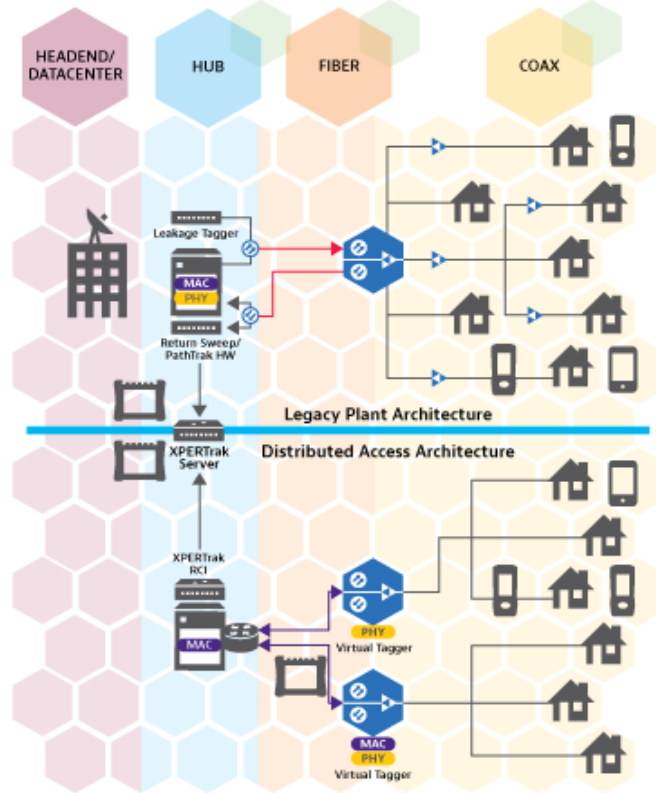

## Fiber Instruments/Accessories



## HFC Instruments



## HFC Sweep

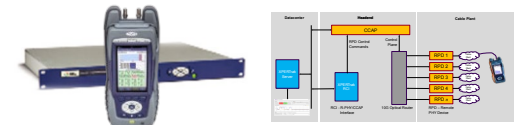

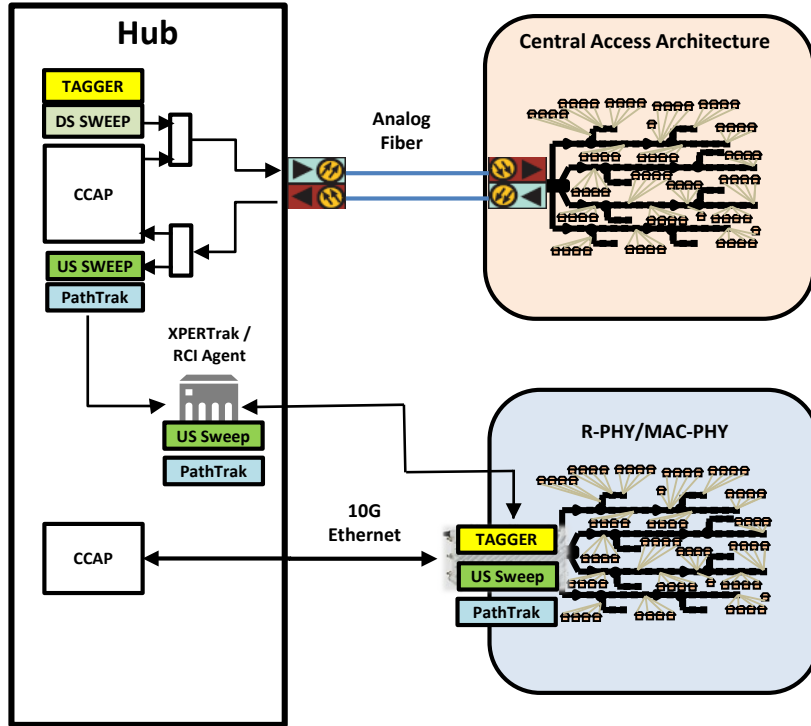

## Today's Hub:

- Return RF Feed For Upstream Tools
- Downstream Sweep RF Injection Point



## DAA Impact:

- No Return RF In Hub
- No Downstream RF Injection Point
- Can't Use Existing Headend HW



**Solution: Integrate DAA Data for Ingress/Sweep**

## Return Sweep/Ingress Example: Common Process & Meter for Legacy/DAA

### Leverage RPD as Return Sweep/Ingress Receiver, Fwd Telemetry Transmitter

- Fast, real-time response
  - Displayed on field meter
- Uses existing field meters
- Standards-based solution
  - Supports most NEM's
- No specialized HW in Hub/HE
  - Scalable/virtualized solution

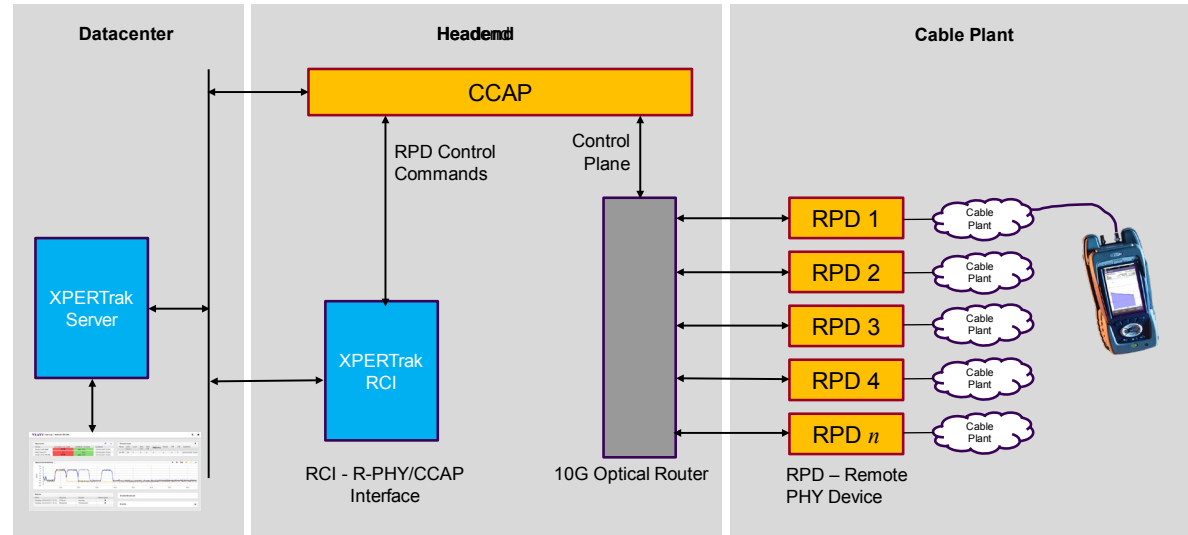



## *Network Equipment Installation*

- Ethernet & Transport Test
- MPO & AOC test
- GPS Antenna Test

## *Shelf RPD Verification*

- Characterize RF
- DOCSIS Service Test
- Video Test
- Voice Test

## *Pull fiber*

- Fiber characterization (CD/PMD)

## *Install DWDM muxes*

- Fiber Inspection
- DWDM OTDR

## *RPD install*

- Fiber inspection
- SFP+ Optics Test
- Ethernet Test
- PTP Test

## *RPD Configuration*

- Characterize RF
- DOCSIS Service Test
- Sweep

- Leakage
- Ingress Suppression
- PTP Wander Tests
- Video Test
- Service Assurance Tests
  - Fiber
  - HFC
  - Ethernet
- All construction and installation tests potentially applicable

## Mission Possible! As Proven by Vodafone New Zealand

### Chose DAA to stay ahead of FTTH competition

- Continue Vodafone NZ trajectory of market leadership
- Capacity challenges also drove urgency

### Chose R-CCAP to enable D3.1/Gigabit rollout

- Full 3.1 deployment – OFDM/OFDMA
- Allowed heavy reuse of existing fiber & RF monitoring infrastructure

### Completed Rollout In 6 Months (257 nodes, 330 R-CCAP units)

- Average 4 nodes per night including validation (~ 1 hour downtime)
- Mix of contractor (Field), new-hires (Headend), and existing staff

## Implementation Summary

### Generic Distributed-CMTS Test & Monitoring Solution (simplified)

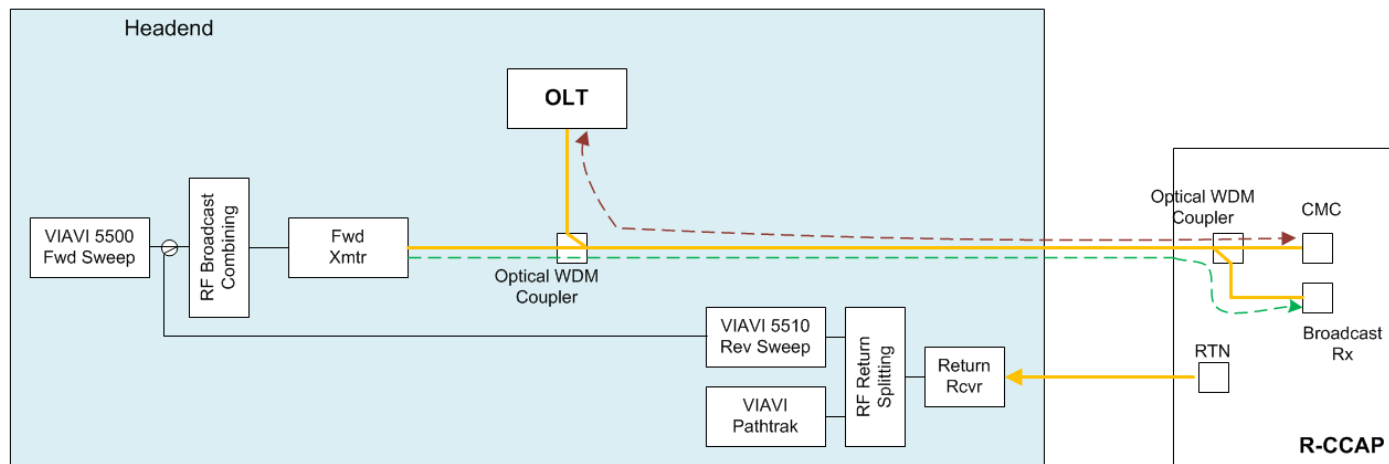

## No RF in Hub

- Short Term: Backfeed RF to Hub, augment with PNM
- Medium/Long Term: Virtualization

## More/Deeper Fiber, Ethernet

- Minimal change in Fiber architecture via WDM usage

## Plant Proliferation/Complexity

- Single vendor today, 100% nodes converted
- Modular instruments, DAA-Ready systems

## Exponential Node Count Growth

- Only moderate node count growth
- QoE-based maintenance tools

## Large Nodes

- Two D-CMTS's co-located in node required for large nodes
  - Node cabinets modified for thermal reasons

## NCP/PLC/Ranging Considerations

- All critical to ODFM/OFDM-A operation
- NCP subcarriers at high-end of spectrum vulnerable to roll-off
- Keep PLC away from known MER dips (harmonics, etc)
- OFDM-A ranging zone defaults to low end – susceptible to ingress

## What Went Well

### Careful Design & Planning Up Front

- Careful network design
- Detailed process planning/definition

### Disciplined Rollout Execution

- Process refined via early pilot runs
- Pre-config/test of all HW pre-deployment

### Early Vendor Engagement

- Test/Maintenance planning started in '15
- Ensure critical T&M capabilities maintained

## Challenges Faced

### Typical “Bleeding Edge” Tech Issues

- Early CCAP/CPE incompatibilities
- Immature FW on both ends

### Phased NEM Capability Implementation

- Service provision capabilities prioritized
- Test, NDF/NDR capabilities lagging

## Everyone Wins From DAA Implementation

### Vodafone NZ Customers Now Have Choices Up To 1Gb/100Mb Broadband Service

- While maintaining superior Vodafone service levels

### Vodafone New Zealand Gains Up To 300% Increased Capacity From HFC Plant

- Mix of 3.0 and 3.1 capacity gain
- Extends HFC life by a decade or more

### Vodafone New Zealand Technical Expertise Gained Through Vendor Engagement

- Upside of being early adopter

## What's Next For DAA & The Evolving HFC?

### Live Plant Rollouts Continue

- Accelerating in 2019

### Full-Duplex DOCSIS

- Further pushes out need for FTTH

### CCAP Moves Upstream & Virtualizes

- Hubs collapse, headends reduced to optical switches
- CCAP virtualizes, moves to datacenters

### Coherent Optics Rewrite Rules For Fiber Capacity

# Thank You!

**David Hering**

Dave.Hering@viavisolutions.com

SCTE • ISBE



ATLANTA, GA  
OCTOBER 22-25

## Our Sponsors—Supporting Industry Growth

