



Deploying IP Video over Cable Networks

Cisco Knowledge Network Series
June 29, 2010

Sangeeta Ramakrishnan
Video Architect, Cable Access BU

John Horrobin
Product Line Manager, Cable Access BU



Agenda

- New Video Technology and Services
- IP Video Device and DOCSIS CPE Connectivity
- DOCSIS 3.0 Network Design for IP Video
- Cisco DOCSIS 3.0 Products
- Cable IP Video Solutions
- Planning and Deployment Services
- Customer Case Study
- Summary

New Video Technology and Services



New Video Technologies

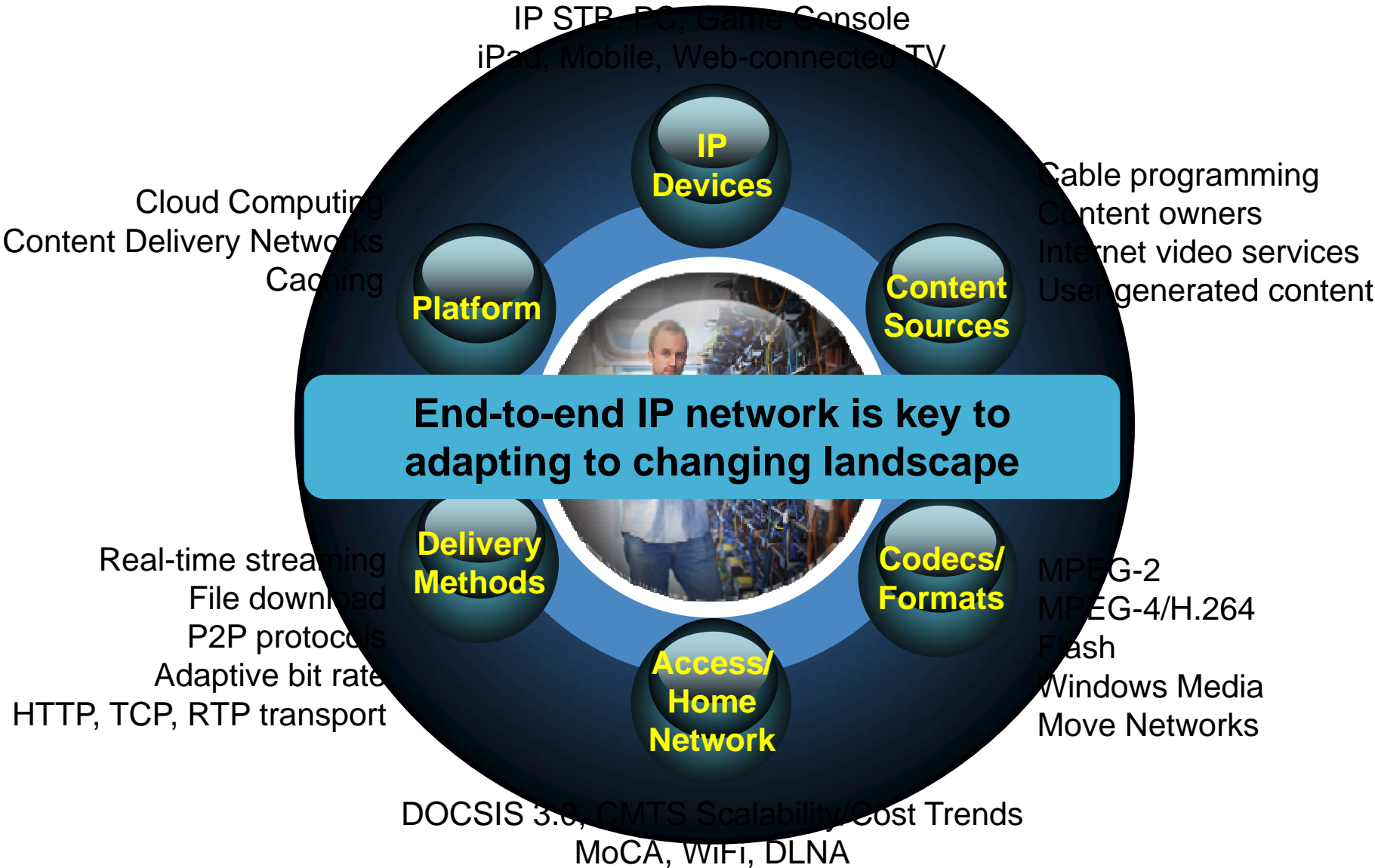

Evolving Video Services



Interactive apps to TVs via
IP STB



- Broadcast TV and VoD to TVs via IP STBs
- Broadcast TV and VoD to PCs, game consoles and other broadband-connected CE devices
- Managed and Unmanaged Services
- Internet video content to TVs via IP STBs (e.g. Hulu, Netflix, YouTube)
- Interactive apps to TVs via IP STB
- Collaborative communications (e.g. Consumer Telepresence)

IP Video Device and DOCSIS CPE Connectivity

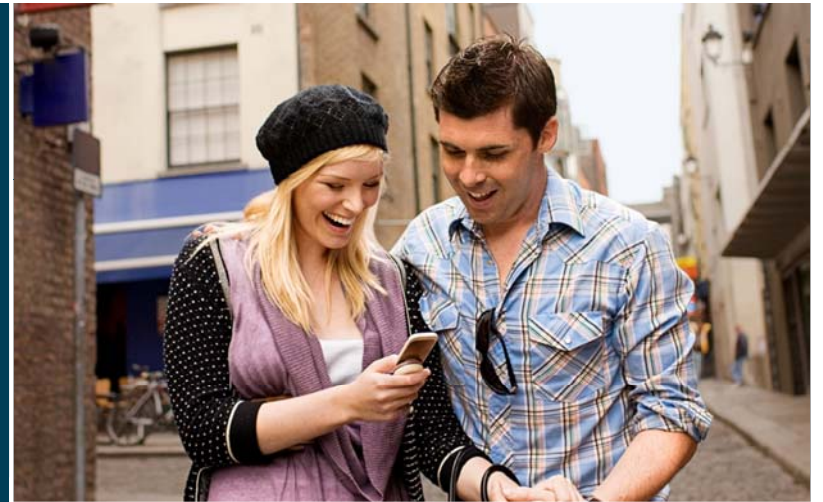

IP Video Device Connectivity

Embedded Cable Modem

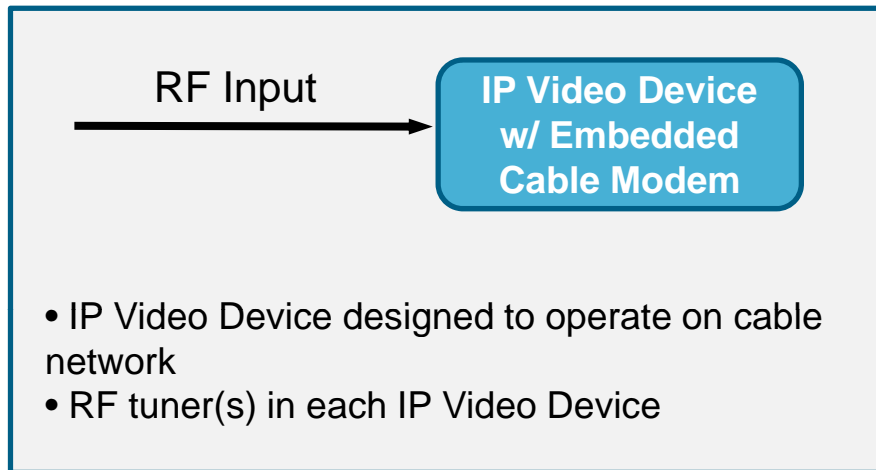

Direct Connect

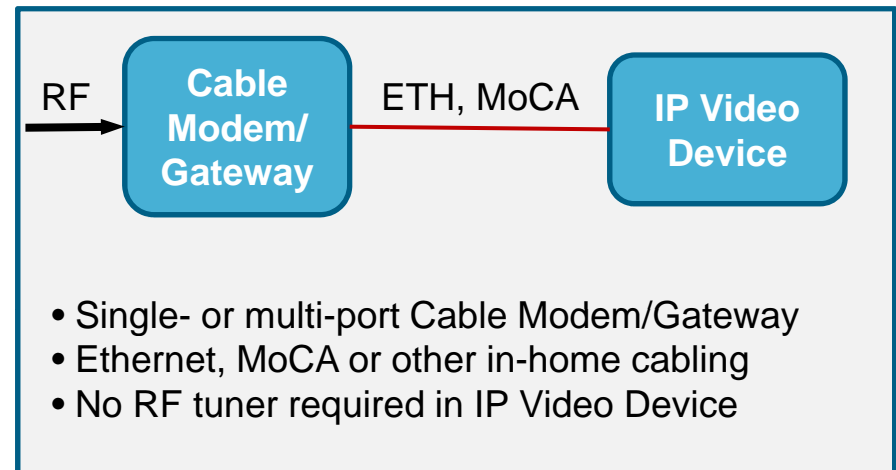

Wired Home Network

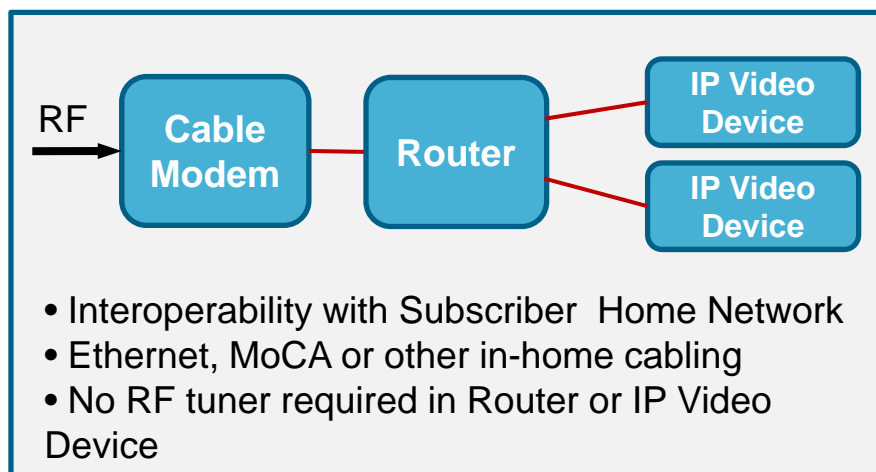

Wireless Home Network

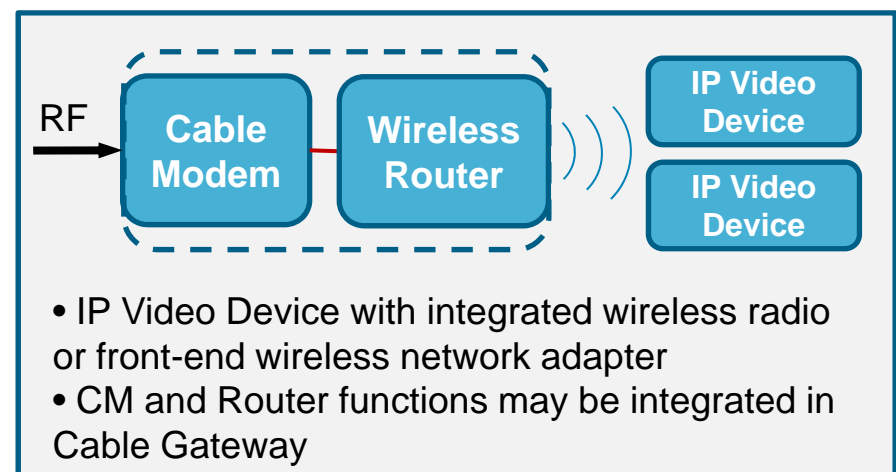

IP Video Delivery in Cable and Home Networks

IP Unicast and IP Multicast

- Popular TV channels sent via IP multicast
- IP Video Device and home network (if applicable) must support IP multicast
- Reduces cable network capacity required for IP Video

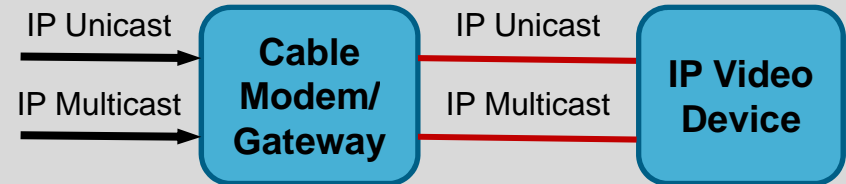

IP Multicast to IP Unicast

- Cable Gateway converts IP multicast to unicast
- Utilize IP multicast in cable network

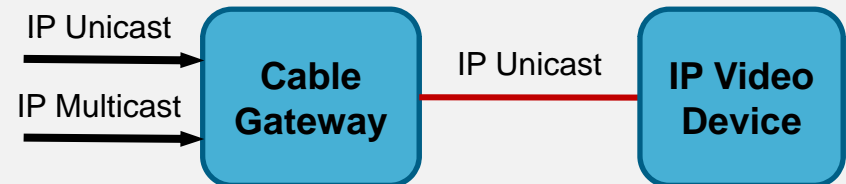

All IP Unicast

- Each IP Video Device receives unique video stream
- No multicast in cable or home network

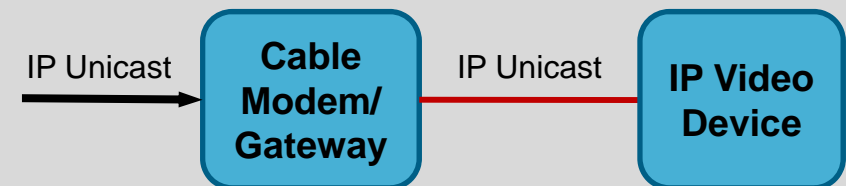

Hybrid MPEG-2 Transport and IP Video

- Hybrid Gateway converts MPEG-2 transport stream to IP unicast
- Deliver new IP Video services and existing digital cable services to IP Video Devices

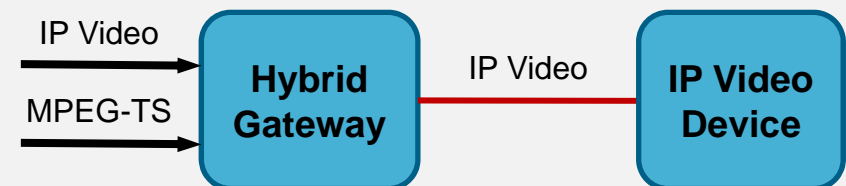

DOCSIS 3.0 Cable Modem Designs

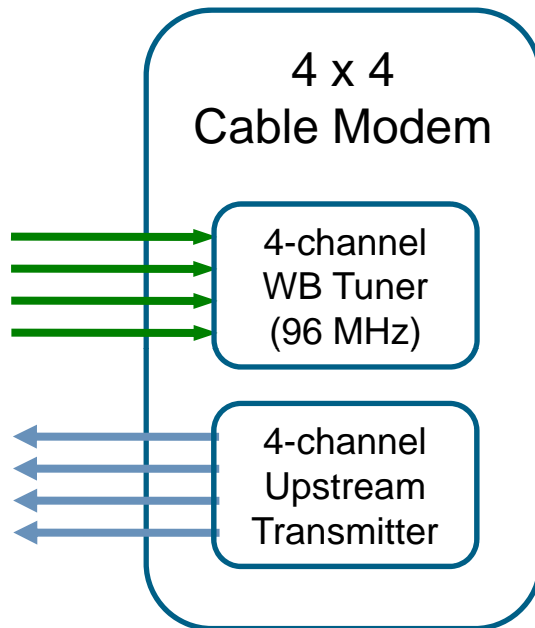

- 4 downstream channels must be within 96 MHz tuning range

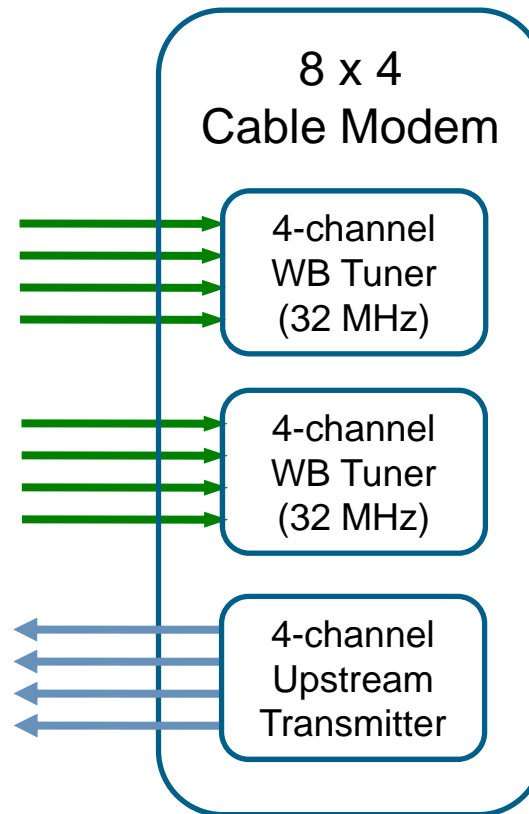

- Each set of 4 DS channels must be within 32 MHz tuning range
- Enables DS channels to be in two frequency ranges

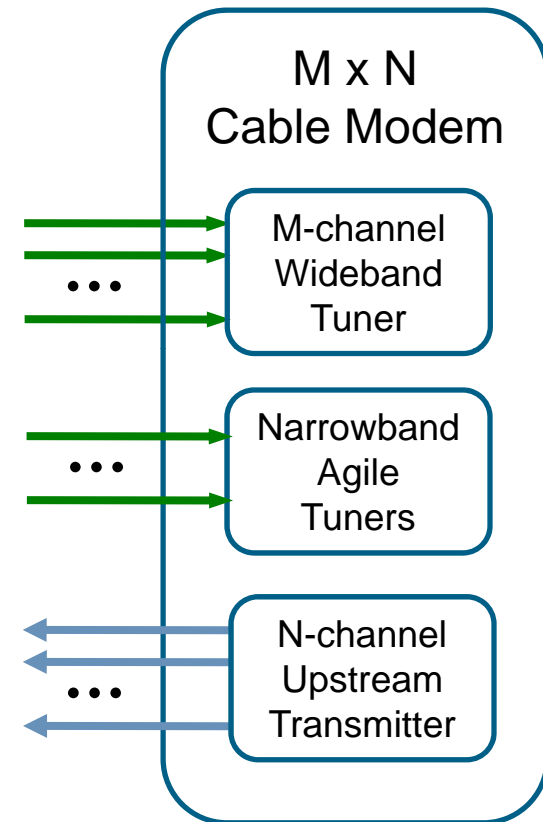

- Future products to support more DS and US channels
- One or more agile NB tuners enable tuning to any frequency

Downstream Service Delivery Options

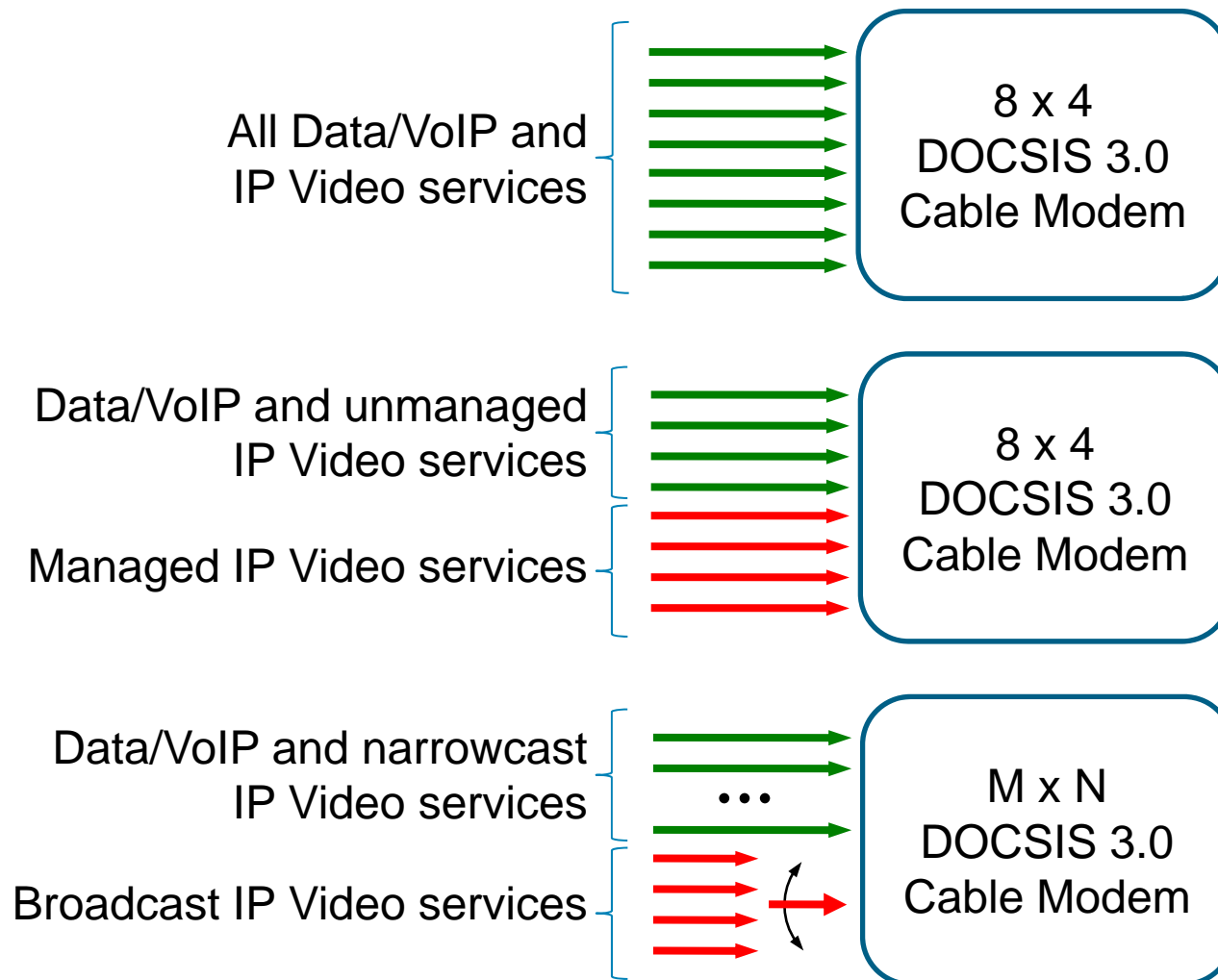

DOCSIS 3.0 Network Design for IP Video



Cisco Video over DOCSIS 3.0 Key Features

- **Channel Bonding**
Fatter pipes enable faster speeds and greater efficiency
- **IP Multicast**
Shared DOCSIS network is ideal for IP multicast of linear TV services
- **RF Spanning**
Scalable and cost-efficient solution with broadcast-style delivery
- **IP Statistical Multiplexing with VBR Video**
Utilize CMTS capabilities to deliver more video streams in less bandwidth
- **Dynamic Bandwidth Sharing**
Improve bandwidth utilization for all services
- **Admission Control and QoS**
Reserve DOCSIS bandwidth and ensure video quality
- **Video-aware Cable Modem Load Balancing**
Support multiple bonding groups per Service Group as IP Video grows

Downstream Channels Shared by All Services

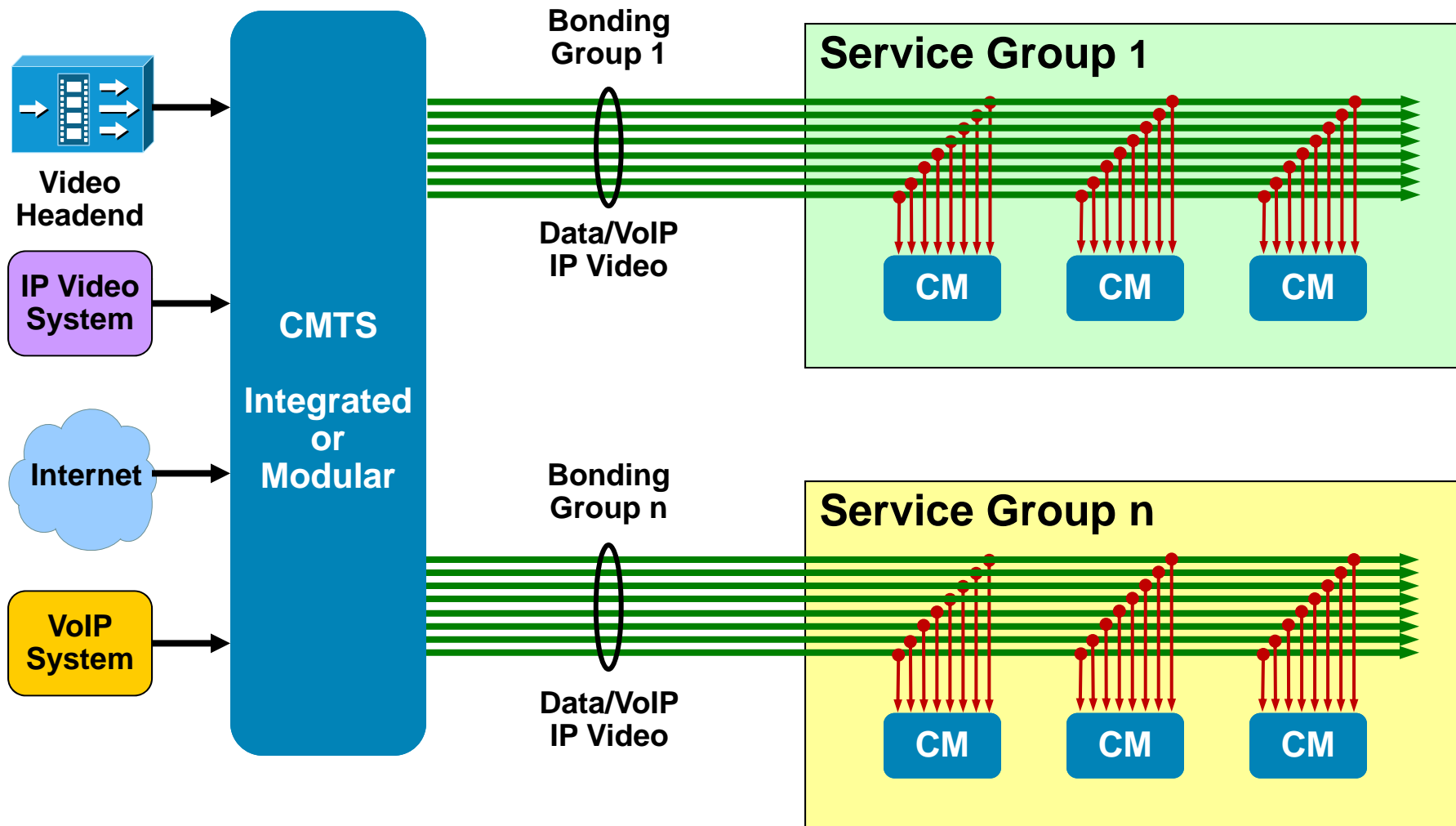

Separate DS Channels for Managed IP Video

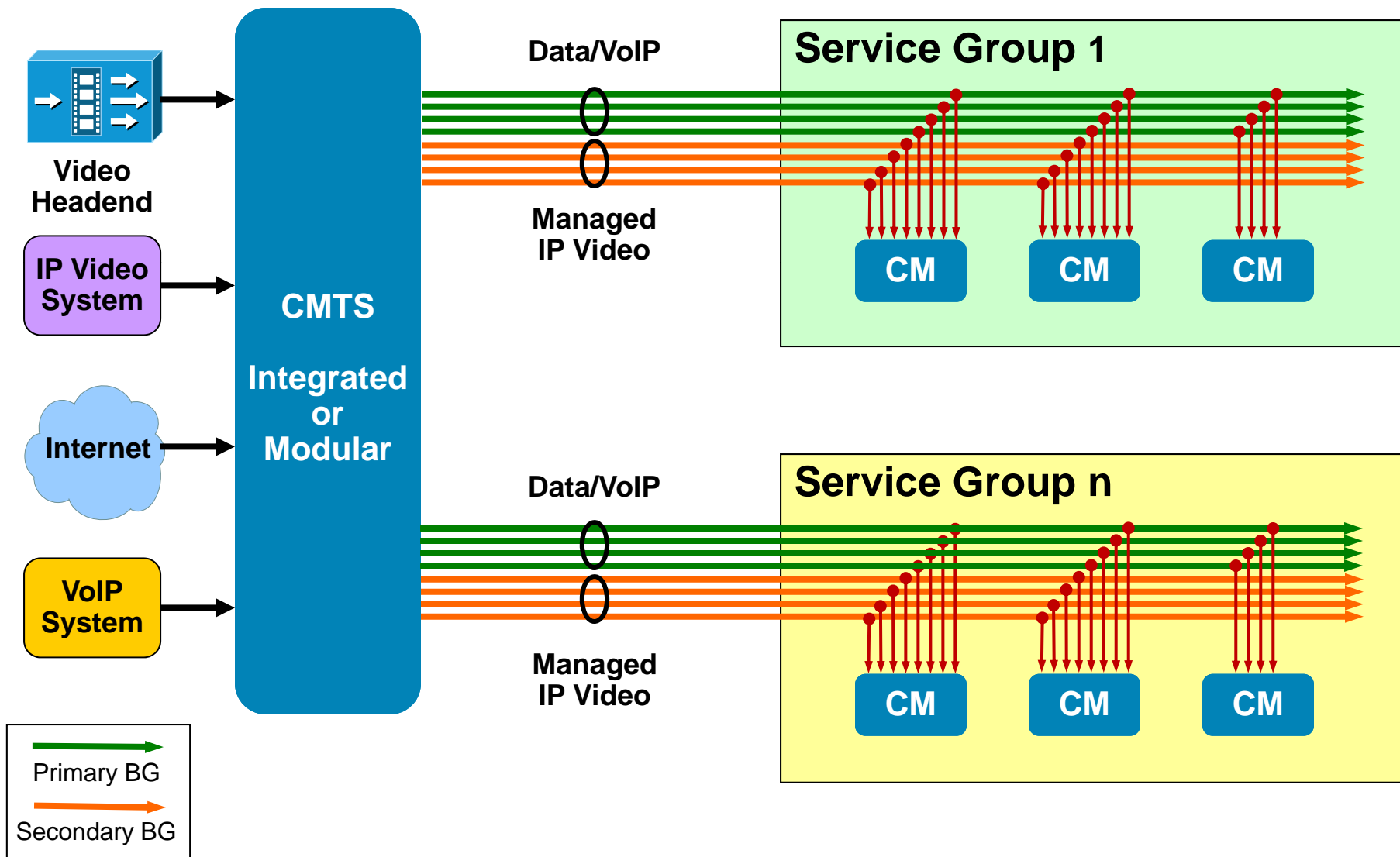

Shared Bonding Group for IP Video

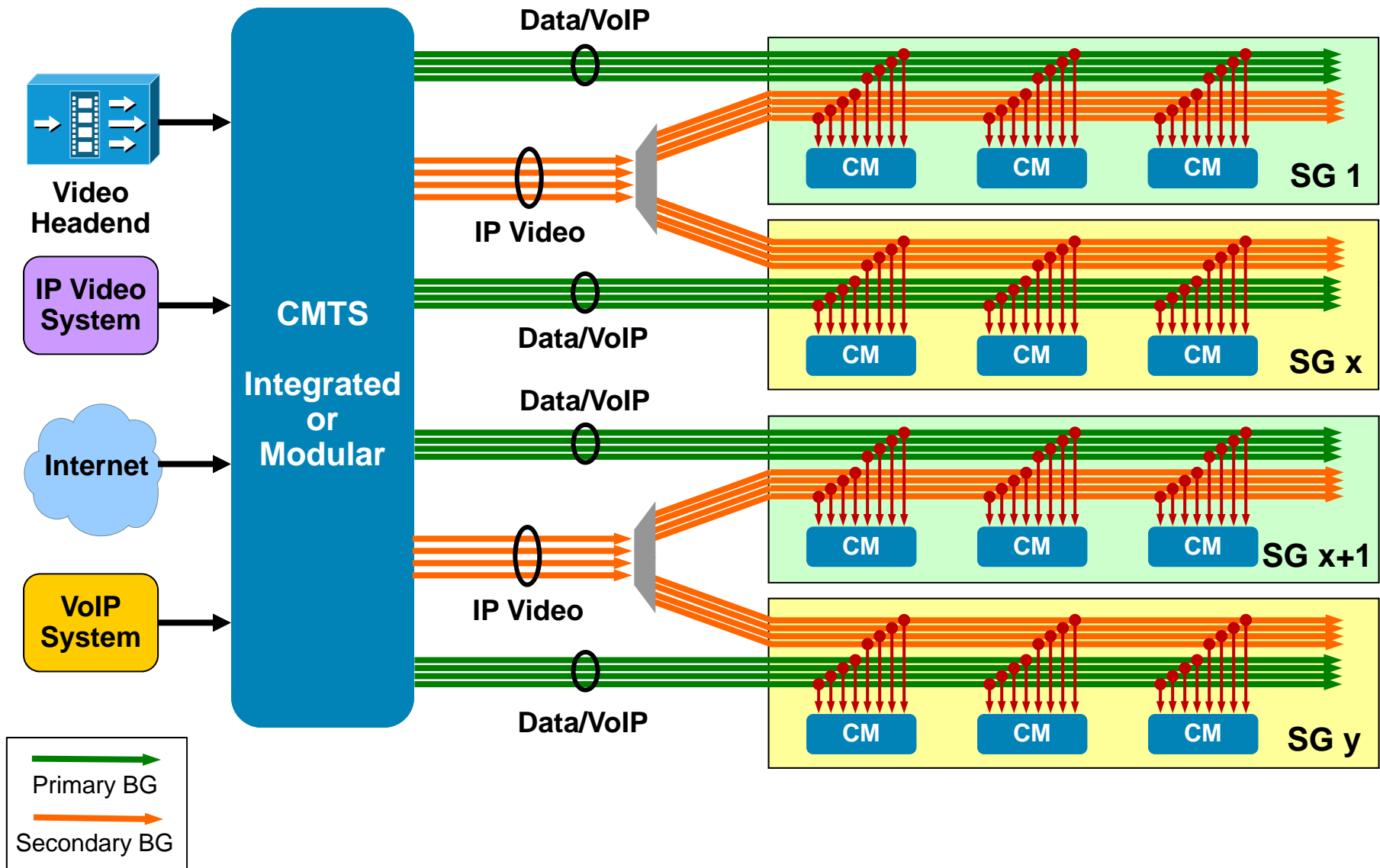

Broadcast IP Video to all Service Groups

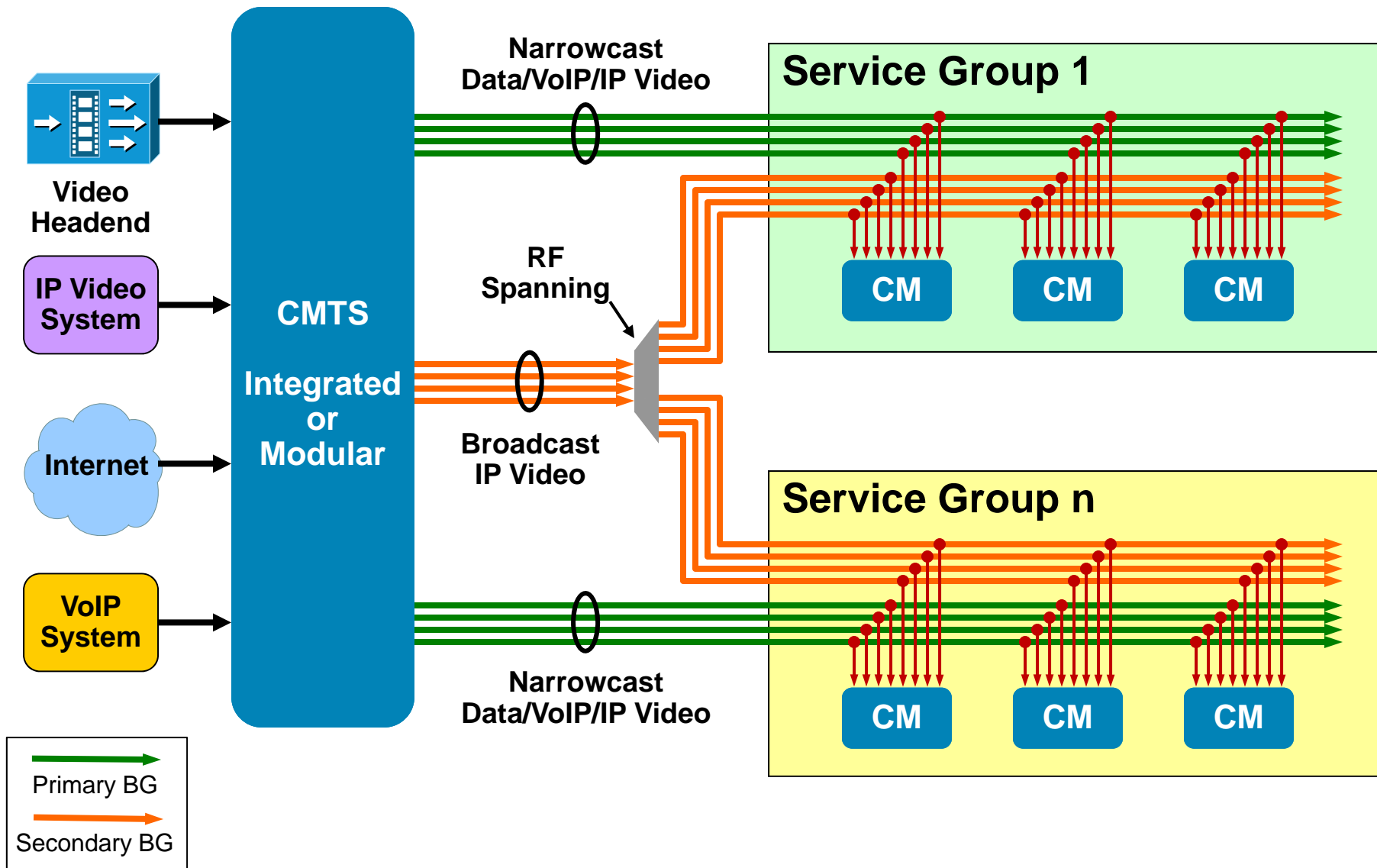

Switched IP Video Example

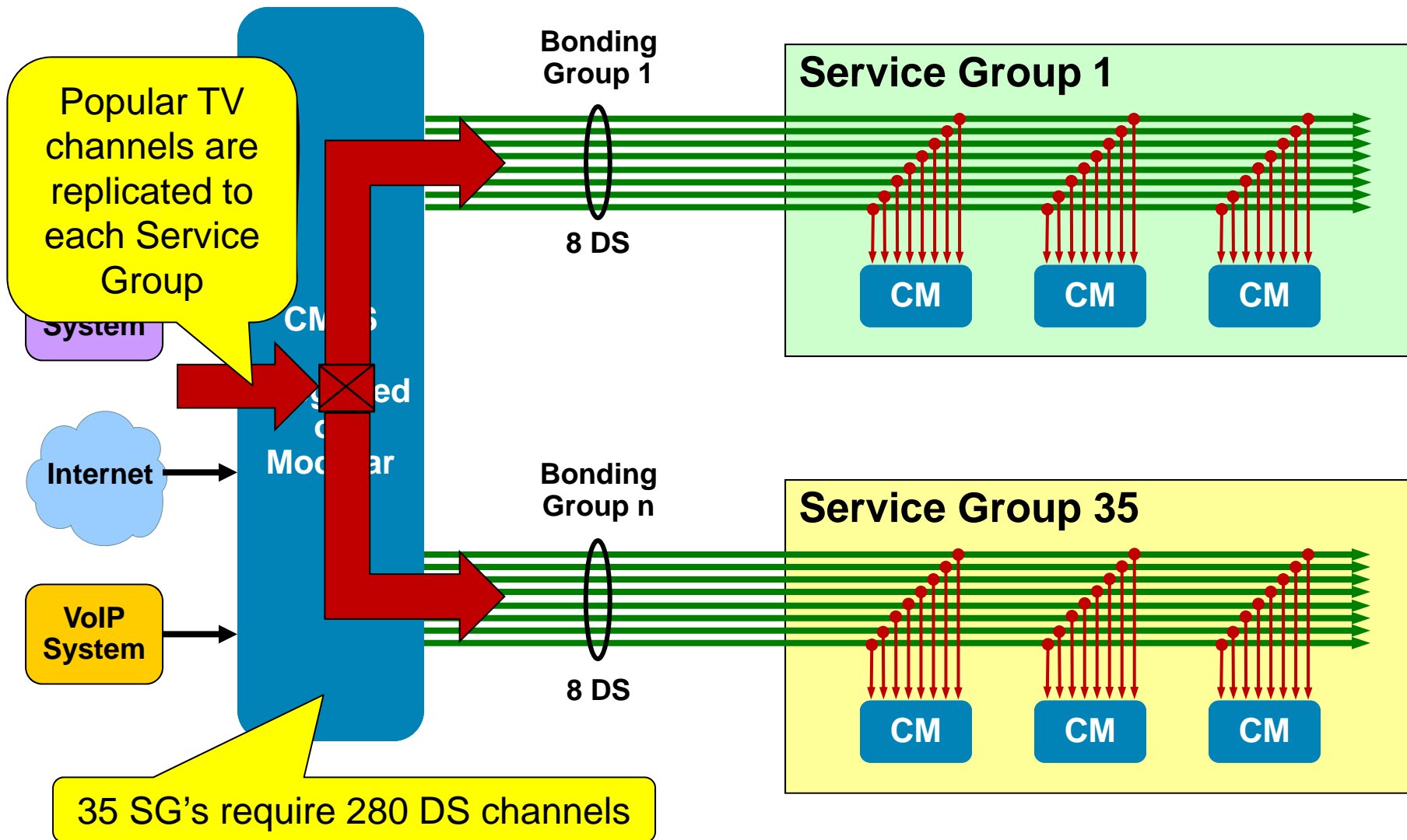

Broadcast IP Video Example

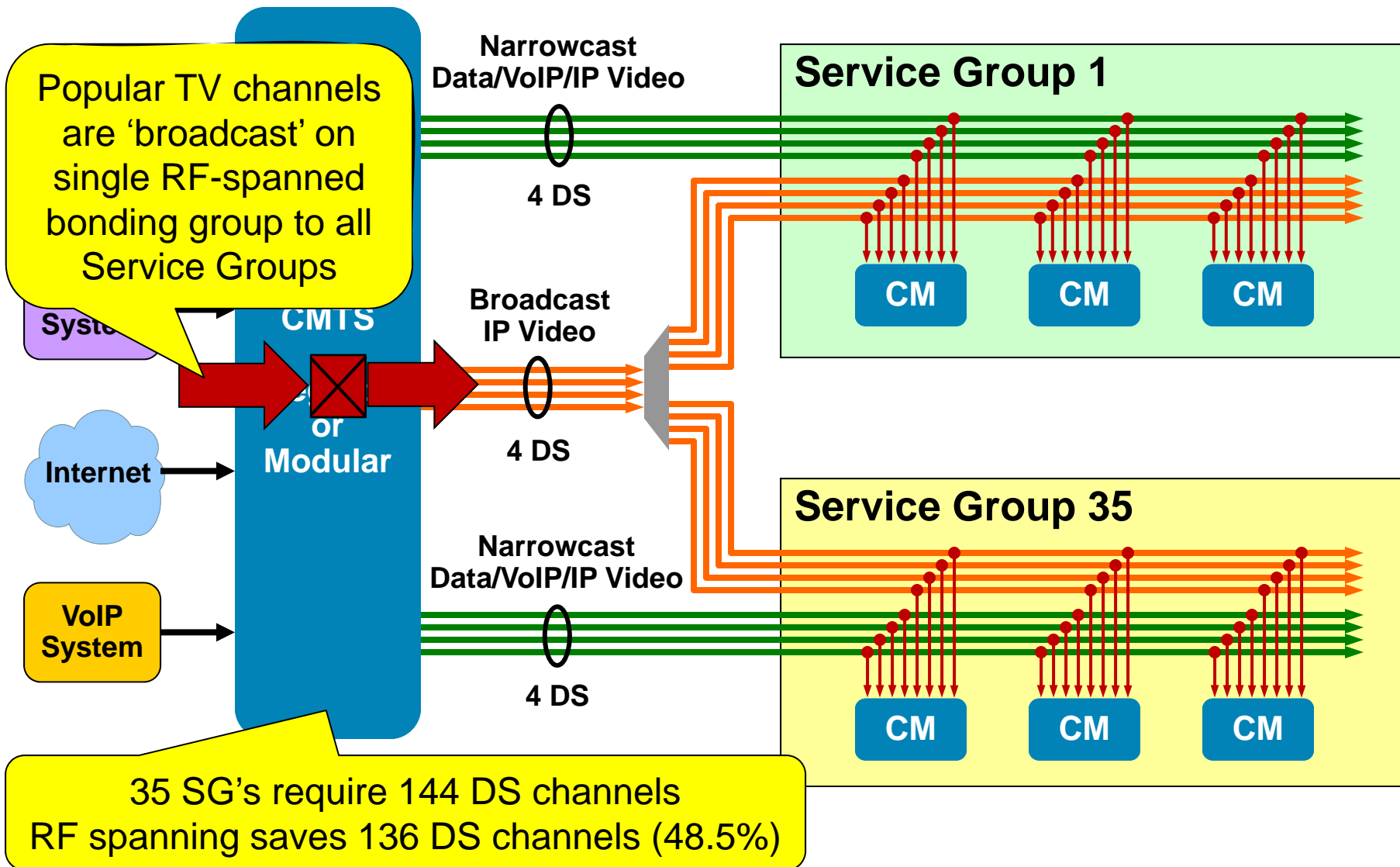

Broadcast IP Video with CM Tuning

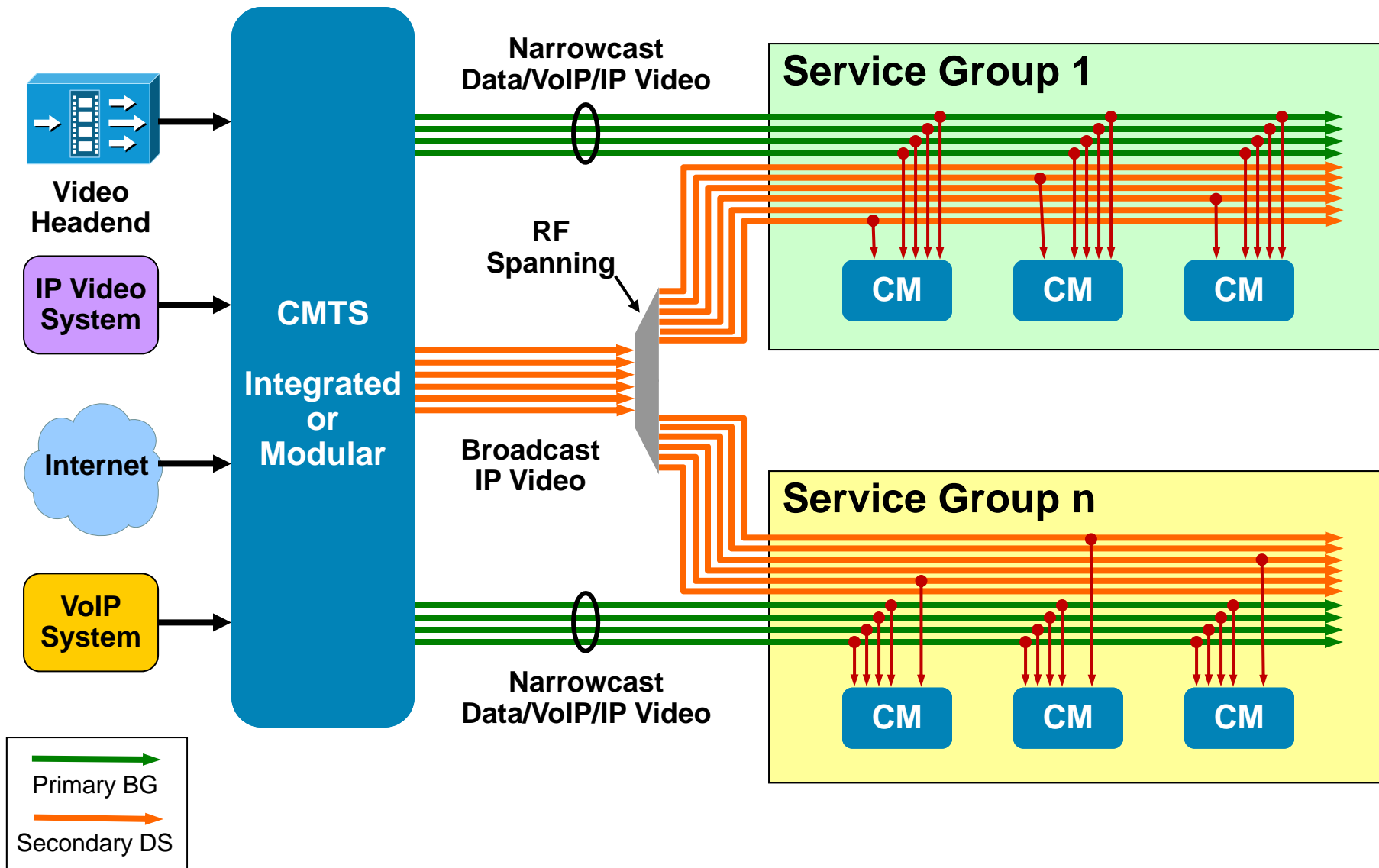

Efficiency Gains from VBR Video

- Support 40 – 60% more streams with VBR video
- Law of large number works in favor of VBR statmux in fat pipe

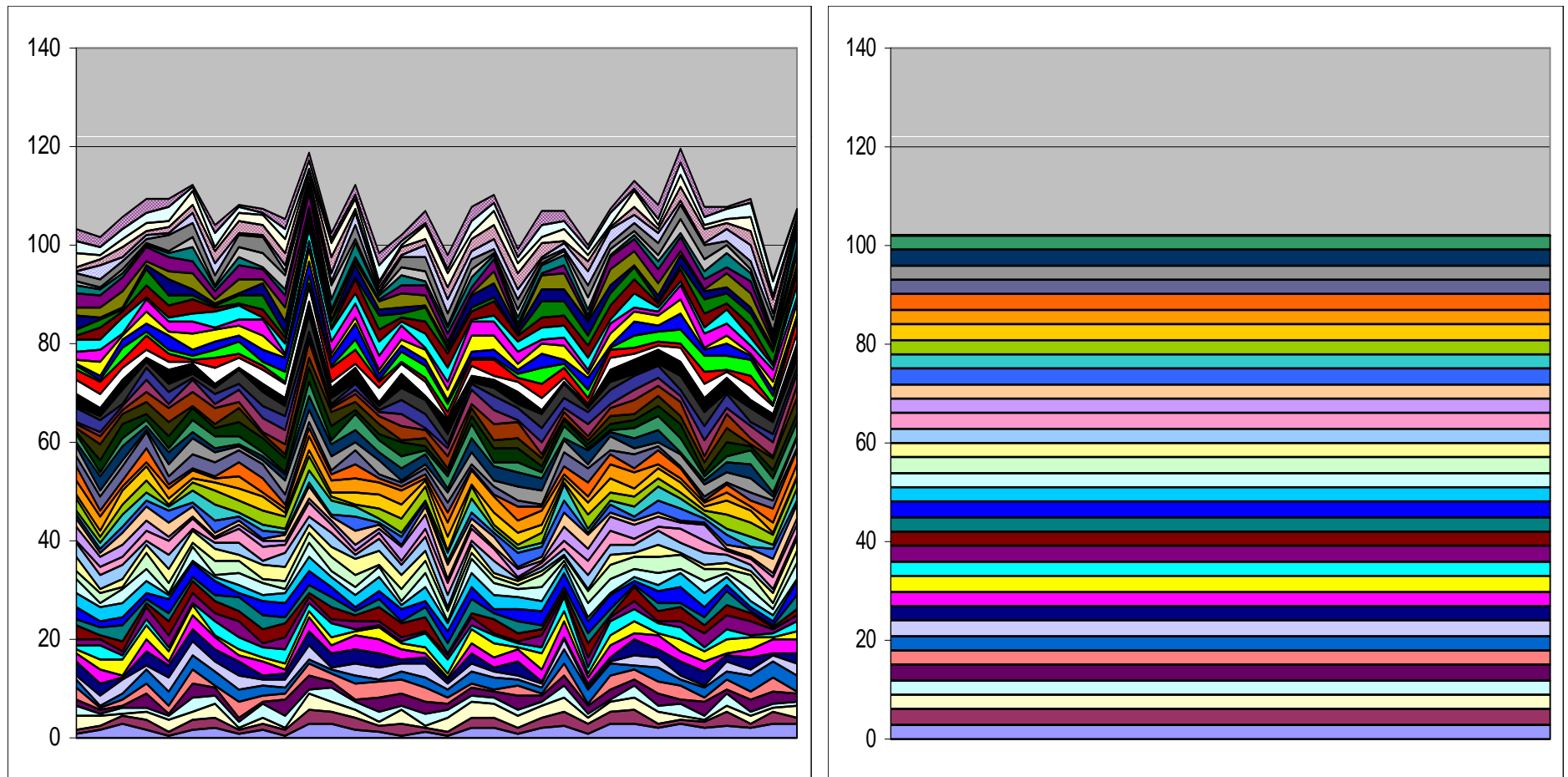

Delivering VBR Video over DOCSIS 3.0 Networks

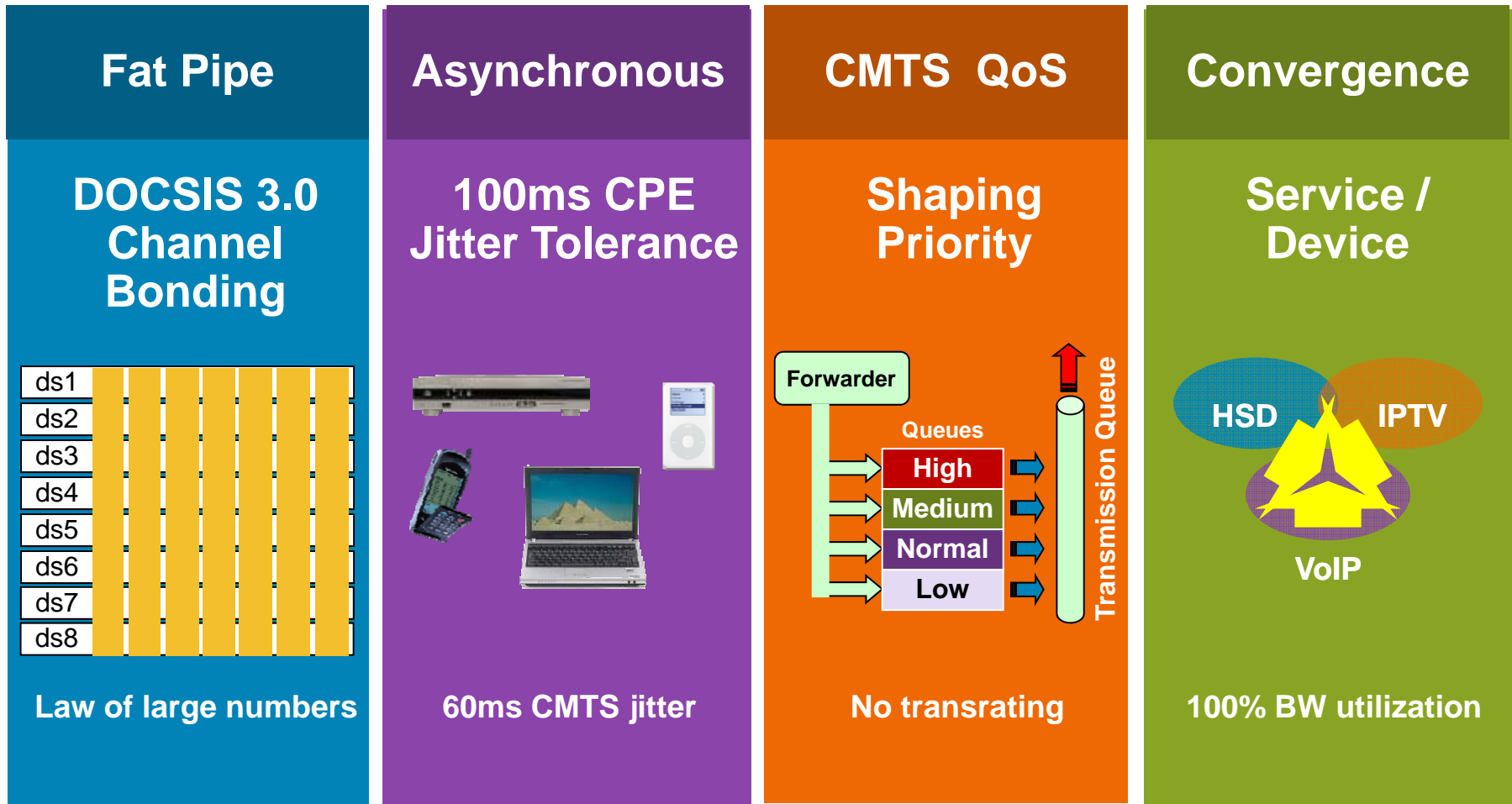

VBR Video over DOCSIS 3.0 with IP Statmuxing

- Unprecedented bandwidth efficiency
 - Up to 50% more streams than CBR video (with 4-channel bonding)
 - 100% bandwidth utilization for convergence
- Cost effective & scalable
 - CMTS queuing instead of transration
 - Scalability independent of codec complexity
- Low latency
- Encryption agnostic
- Superior picture quality



CBR

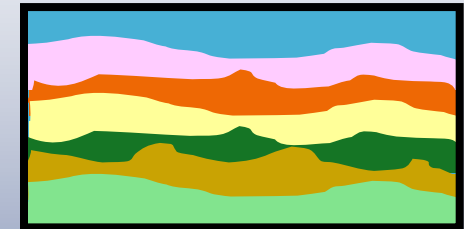

VBR w. MPEG Statmux

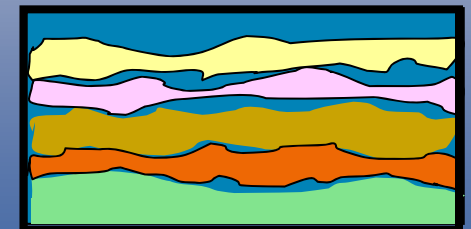

VBR Video over DOCSIS

Dynamic Bandwidth Sharing

- Data and video services delivered in shared bonding group
- Data service “sponges” excess bandwidth not used by video

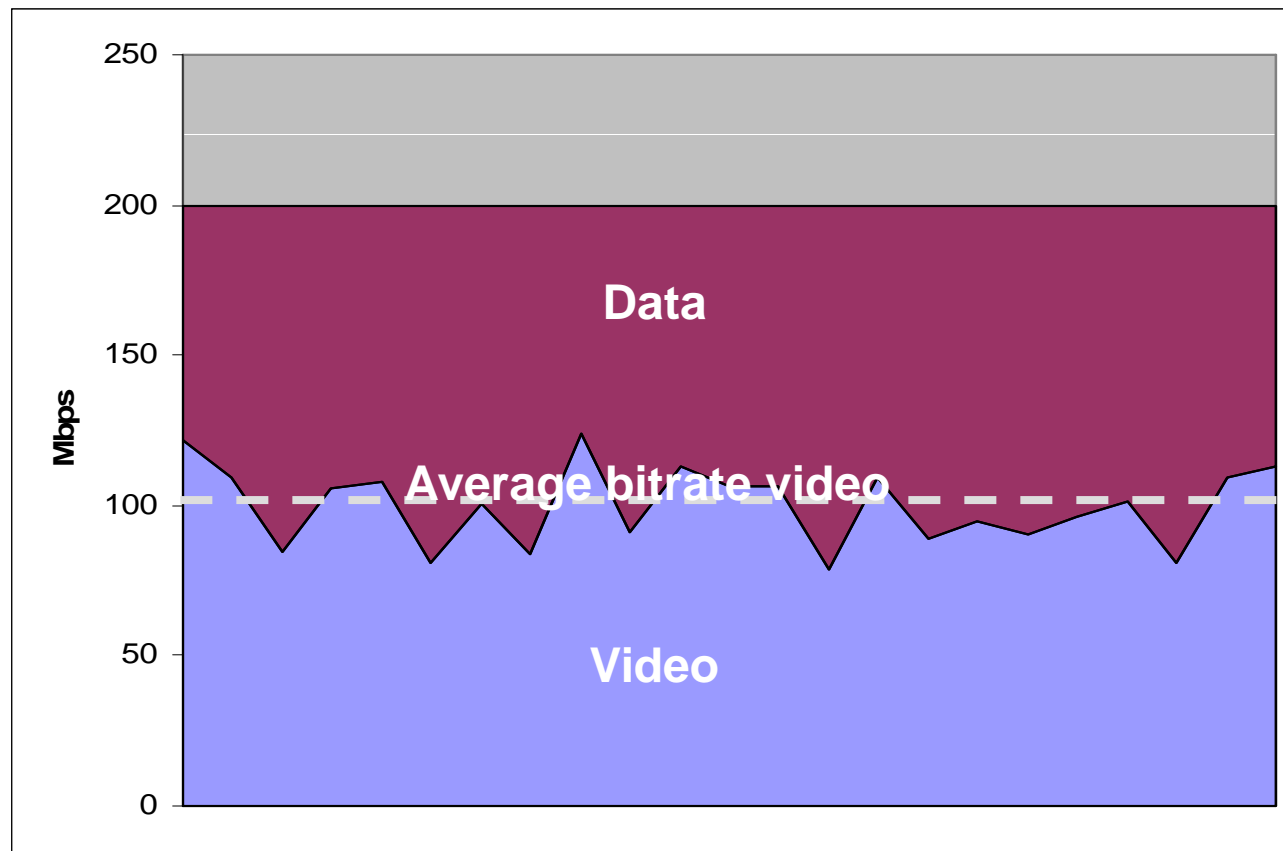

Admission Control and QoS

VoD: PCMM

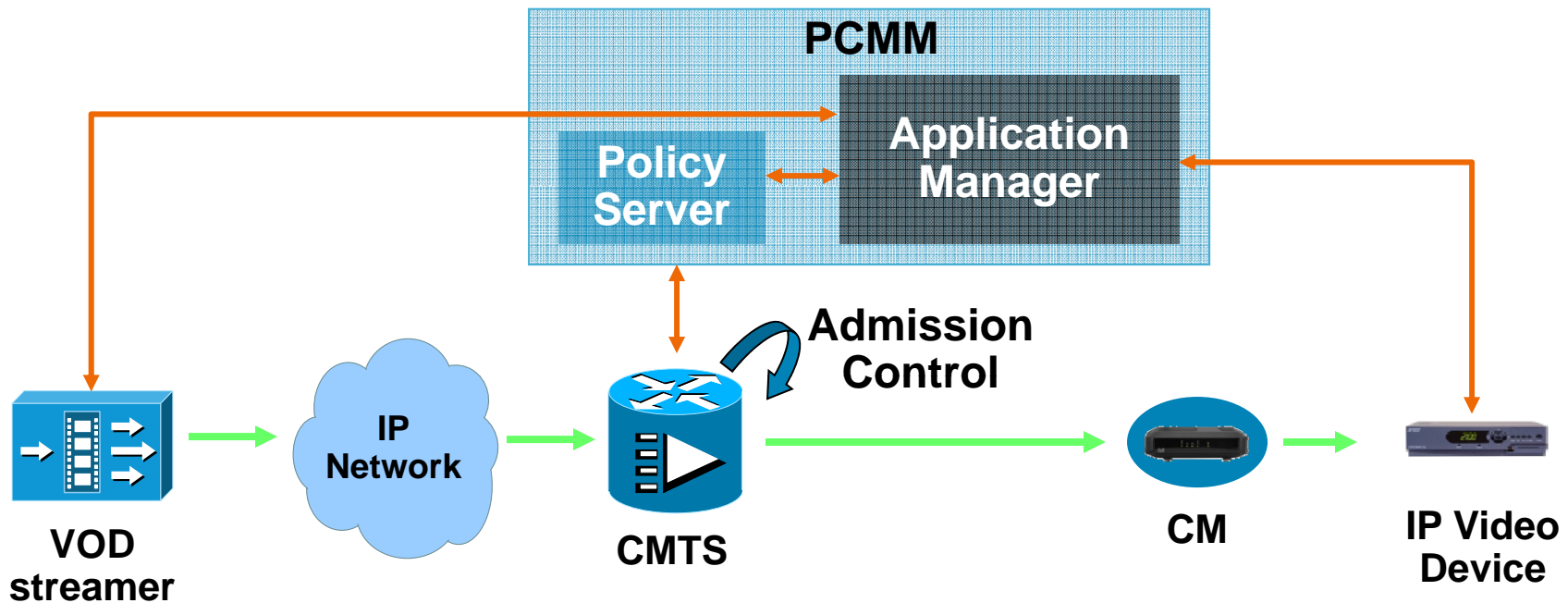

- CMTS forwards unicast video streams based on PCMM signaling
- Policy Server performs authorization checks and signals CMTS with QoS requirements
- Upon receipt of Gate-Set, CMTS creates classifier and service flow and reserves bandwidth
- Flexible forwarding to cable interface based on service flow attributes

Admission Control and QoS

Multicast: PCMM

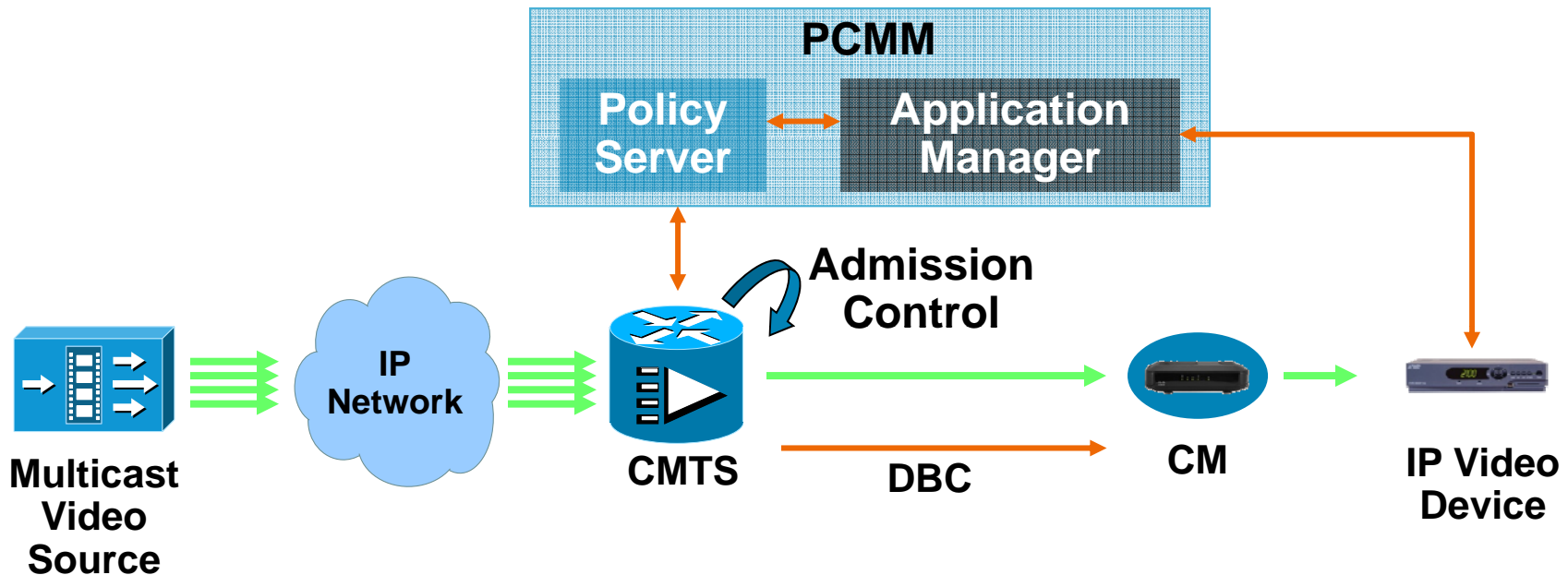

- Multicast extensions included in PCMM IO5
- CMTS dynamically forwards multicast video streams based on PCMM signaling
- Policy Server performs authorization checks and signals CMTS with QoS requirements

Admission Control and QoS

Multicast: IGMP

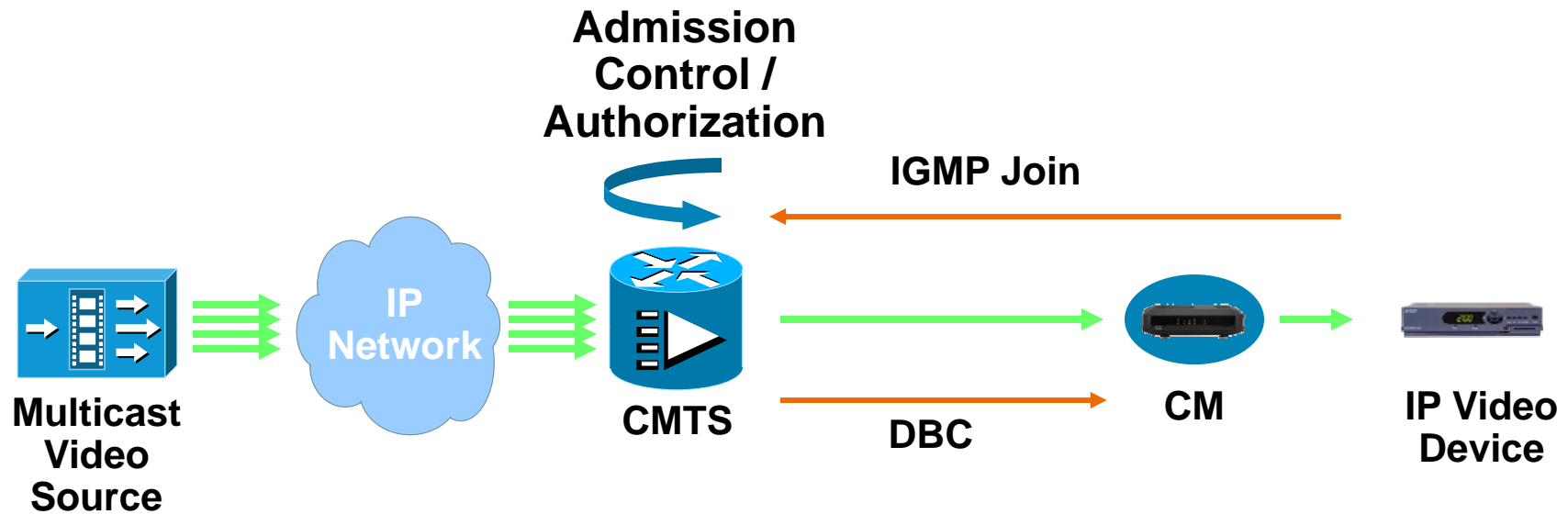

- CMTS forwards multicast video streams based on IGMP traffic from IP Video Device
- CMTS pre-configured with video service class
- CMTS performs admission control and multicast authorization

CM Load Balancing

Downstreams shared for all services

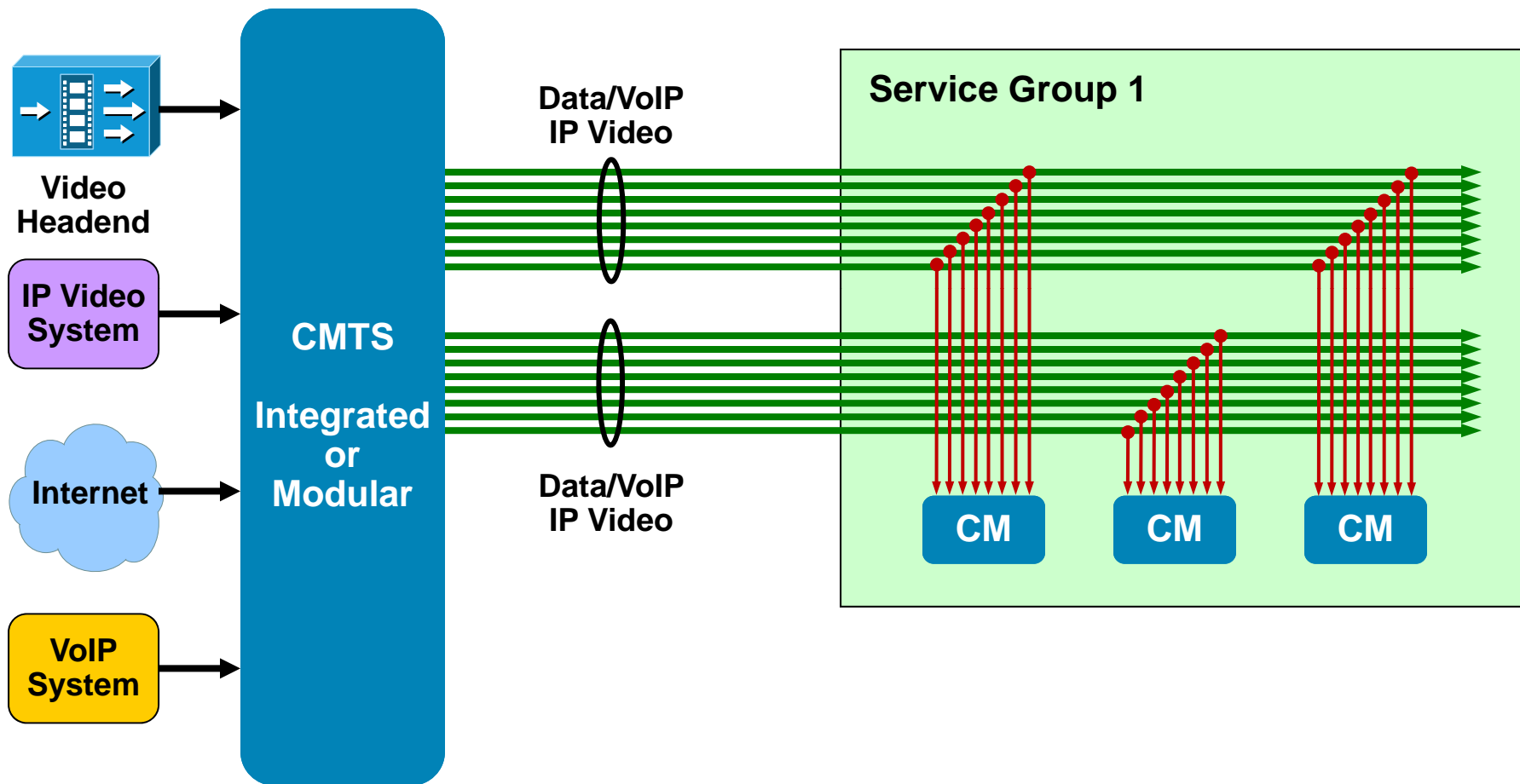

CM Load Balancing

Separate set of downstreams for IP Video

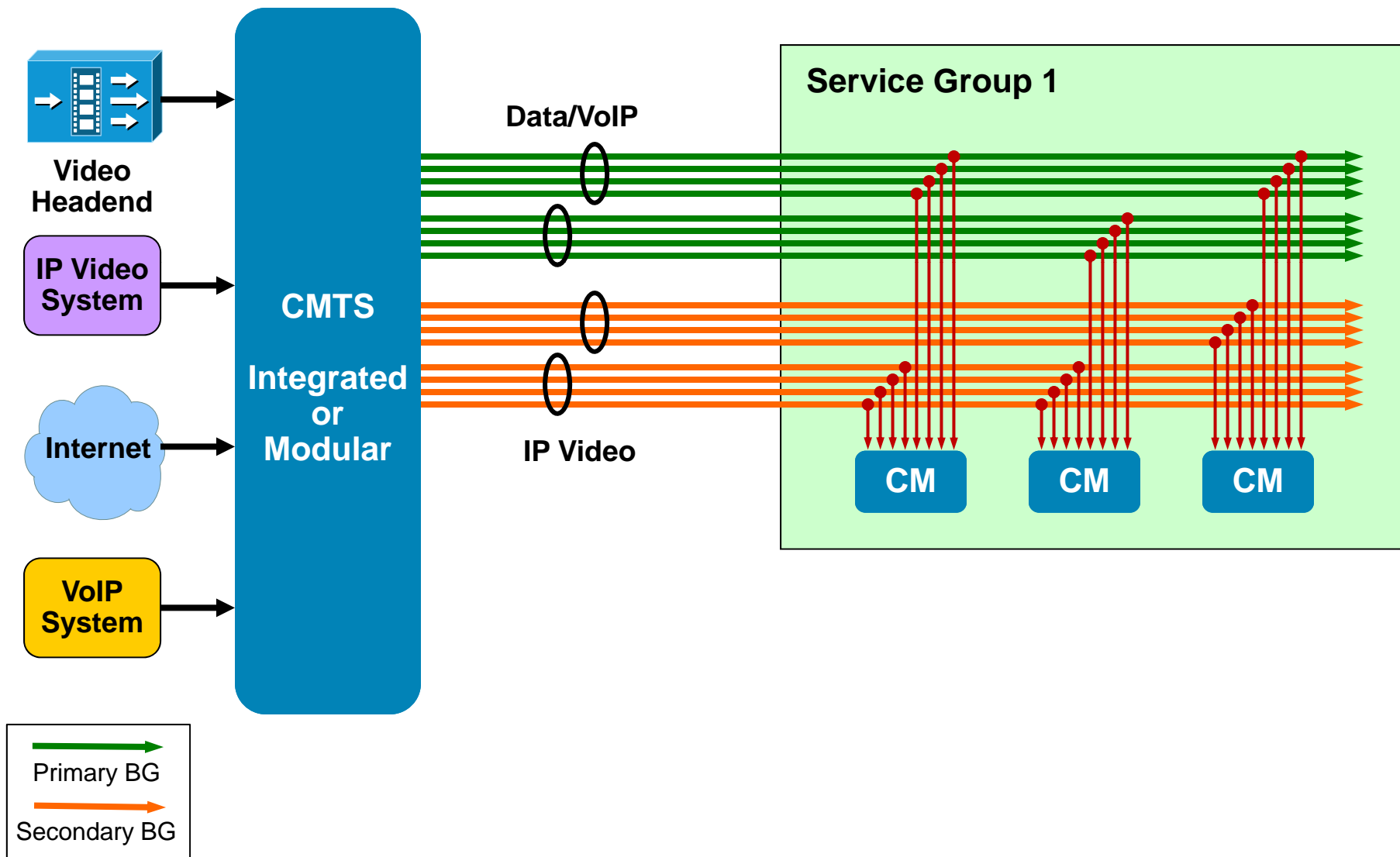

Cisco DOCSIS 3.0 CMTS Products



CMTS Product Portfolio



uBR7225VXR

- 1M pps
- Up to 16 DS and 16 US channels per chassis
- I-CMTS
- Full DOCSIS® 3.0



uBR7246VXR

- 1M pps
- Up to 32 DS and 32 US channels per chassis
- I-CMTS
- Full DOCSIS® 3.0



uBR10012

- 6M pps
- Carrier Class
- Up to 304 DS and 160 US channels per chassis today
- I-CMTS & M-CMTS
- Full DOCSIS® 3.0



Common DOCSIS & IOS Software features

UBR-MC20X20V Line Card

Full DOCSIS 3.0 Solution for uBR10012

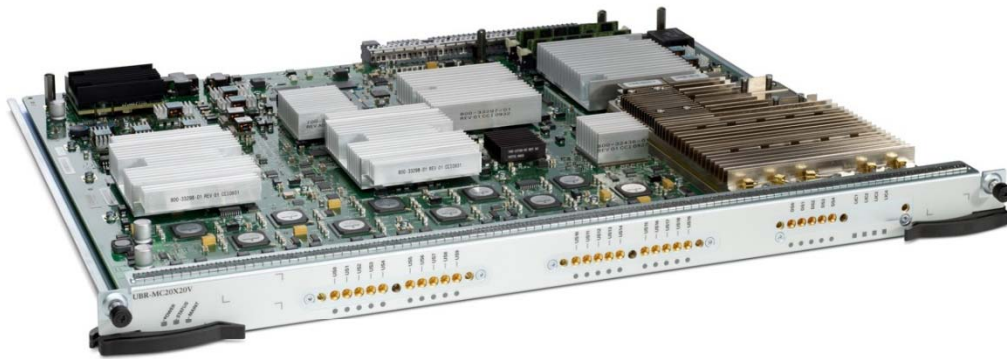

UBR-MC20X20V

- Full DOCSIS 3.0 line card for uBR10012 CMTS
- 20 DS channels (5 RF ports)
 - 4 QAM stacking
- 20 US channels (20 US ports)
- Up to 160 DS channels per CMTS
- Up to 304 DS channels per CMTS when used with Wideband SPA
- Same RF connectivity as MC5X20
 - Ease of deployment
- Full High Availability support
- Options for 0, 5 and 20 DS channels
 - Pay as you grow with SW licensing
- Supported in 12.2(33)SCC and later

UBR-MC88V Line Card

Extending uBR7200 Series to DOCSIS 3.0

- Full DOCSIS 3.0 line card for uBR7200 Series
- 8 DS channels (2 DS ports)
 - 4 QAM stacking
- 8 US channels (8 US ports)
- Up to 2 line cards per uBR7225VXR chassis
- Up to 4 line cards per uBR7246VXR chassis
- 4x DS density of the MC28U line card
- Supported in 12;2(33)SCD and later



UBR-MC88V

Example Bandwidth Requirement for Managed IP Video Services

	Near Term	Medium Term	Long Term
RF channels required (CBR)	6	15	28
Spanned DS channels (CBR)	0	4	4
Narrowcast DS channels per SG (CBR)	6	11	24
RF channels required (VBR)	4	10	19
Spanned DS channels (VBR)	0	4	4
Narrowcast DS channels per SG (VBR)	4	6	15

- SG = Service Group (500 homes passed per SG in this example)
- CBR = Constant Bit Rate
- VBR = Variable Bit Rate

CMTS Price vs Density

Enabling IP Video with Lower Cost per Channel and Higher Density

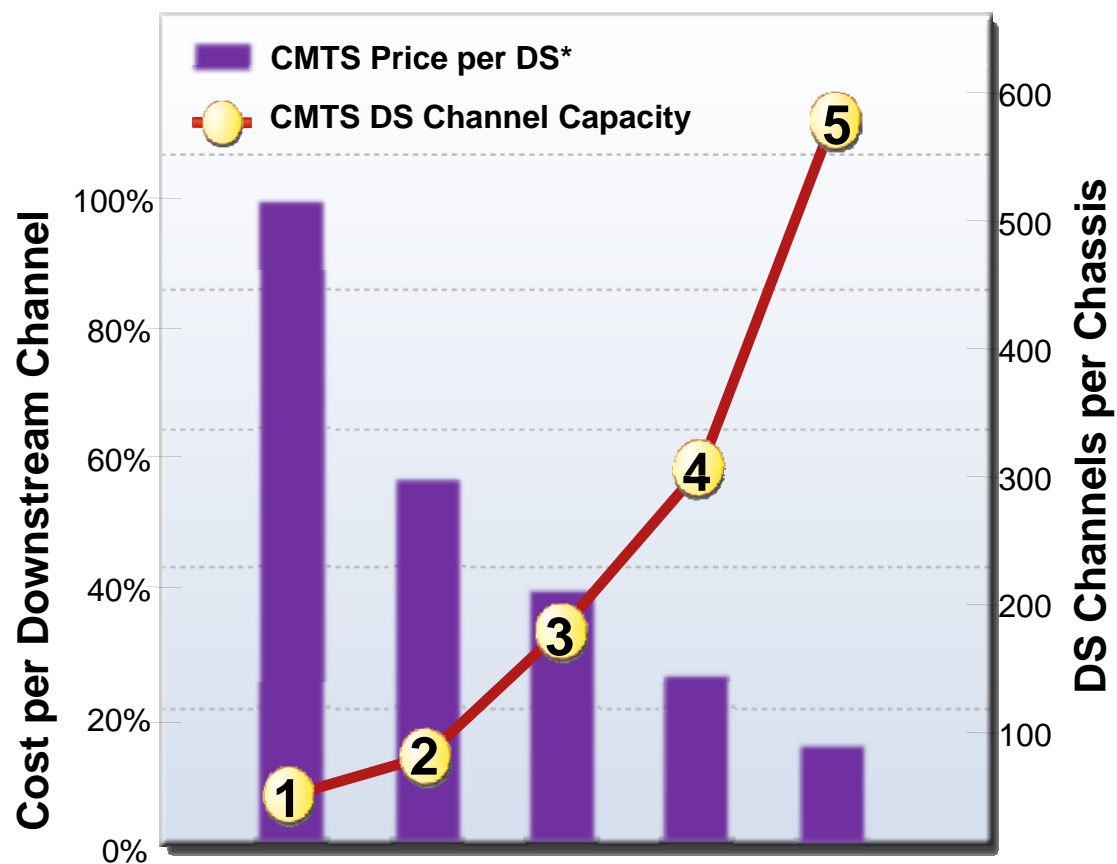

1: MC5X20 Line Card

5 Integrated 1.x/2.0 DS
20 Integrated 1.x/2.0 US

2: Wideband SPA

24 Modular DS with 3.0 DSCB
2 SPA per uBR10012

3: High-density SPA Carrier

6 SPA per uBR10012

4: MC20X20 Line Card

20 Integrated 3.0 DS
20 Integrated 3.0 US

5: MC3G60 Line Card

72 Modular 3.0 DS
60 Integrated 3.0 US

* CMTS price per DS includes US and commons

Cisco Cable IP Video Solution Designs



All Systems Target Certification as Cisco Validated Designs (CVD)

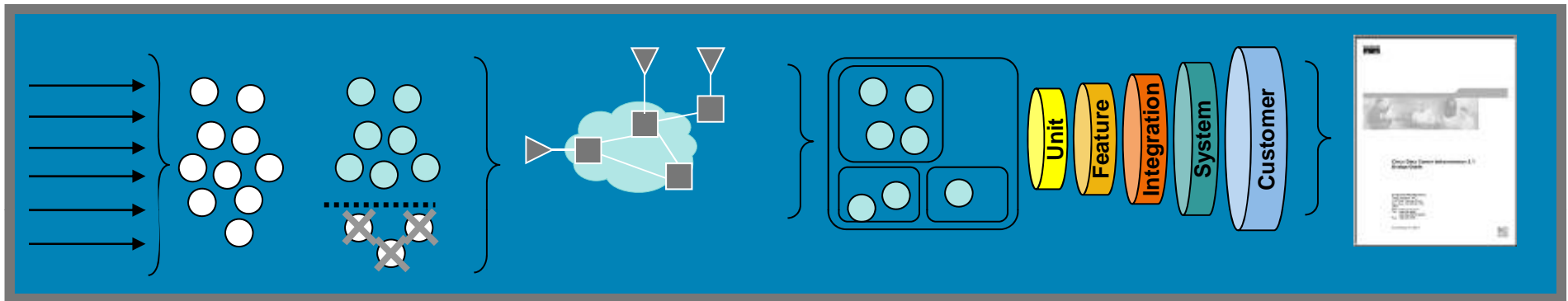

Planning

Systems Design

Systems End-to-End Verification

Customer Documentation

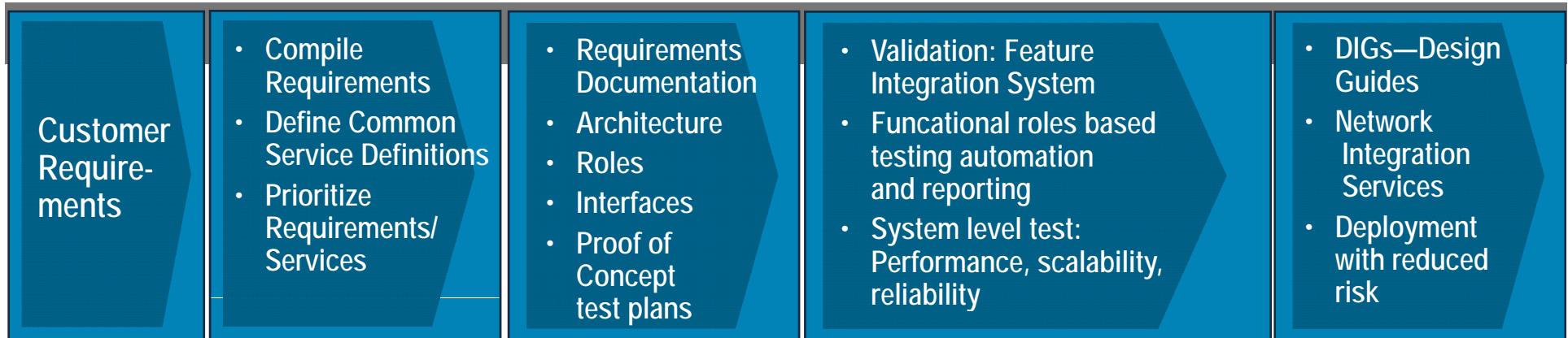

System Reference Designs

Next-generation Video Infrastructure (NGVI)

Modular and Middleware Independent

An All-IP Network for a New Generation of Interactive Services

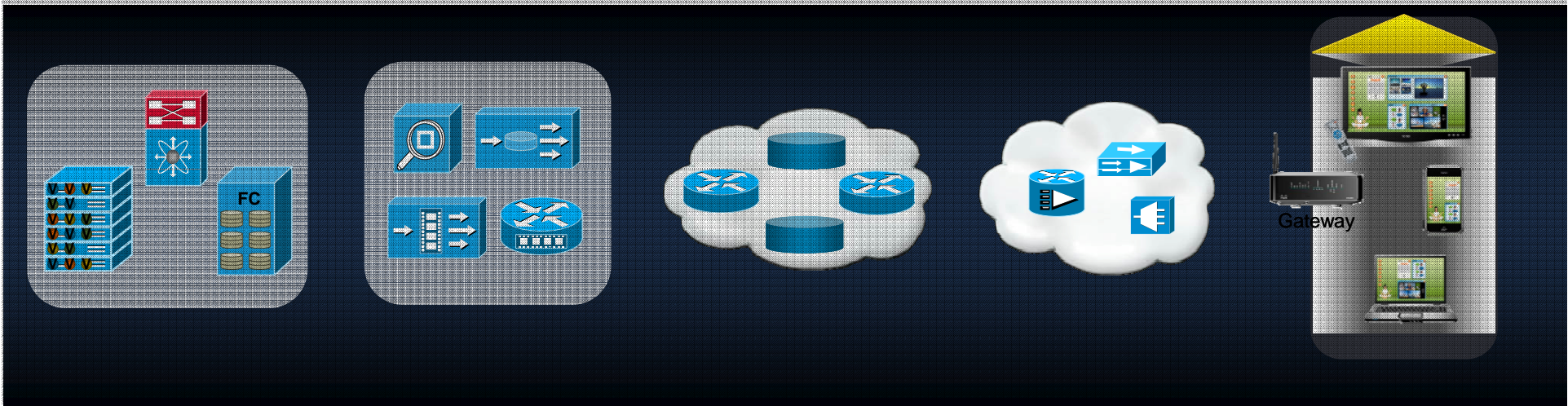

Video Data Center	Content Delivery Network	IP/NGN	Access	Home
<ul style="list-style-type: none"> Content acquisition, storage and management Unified computing system Middleware hosting Virtualize services and applications 	<ul style="list-style-type: none"> Ingest and distribute massive content Intelligent caching Serve multiple end devices 	<ul style="list-style-type: none"> Guaranteed service delivery Media aware 	<ul style="list-style-type: none"> Full DOCSIS 3.0 Converged Network High Scalability High Availability Optimized for video 	<ul style="list-style-type: none"> Immersive experience Many devices Personalized services

Next-generation Video Infrastructure (NGVI)

Modular and Middleware Independent

An All-IP Network for a New Generation of Interactive Services

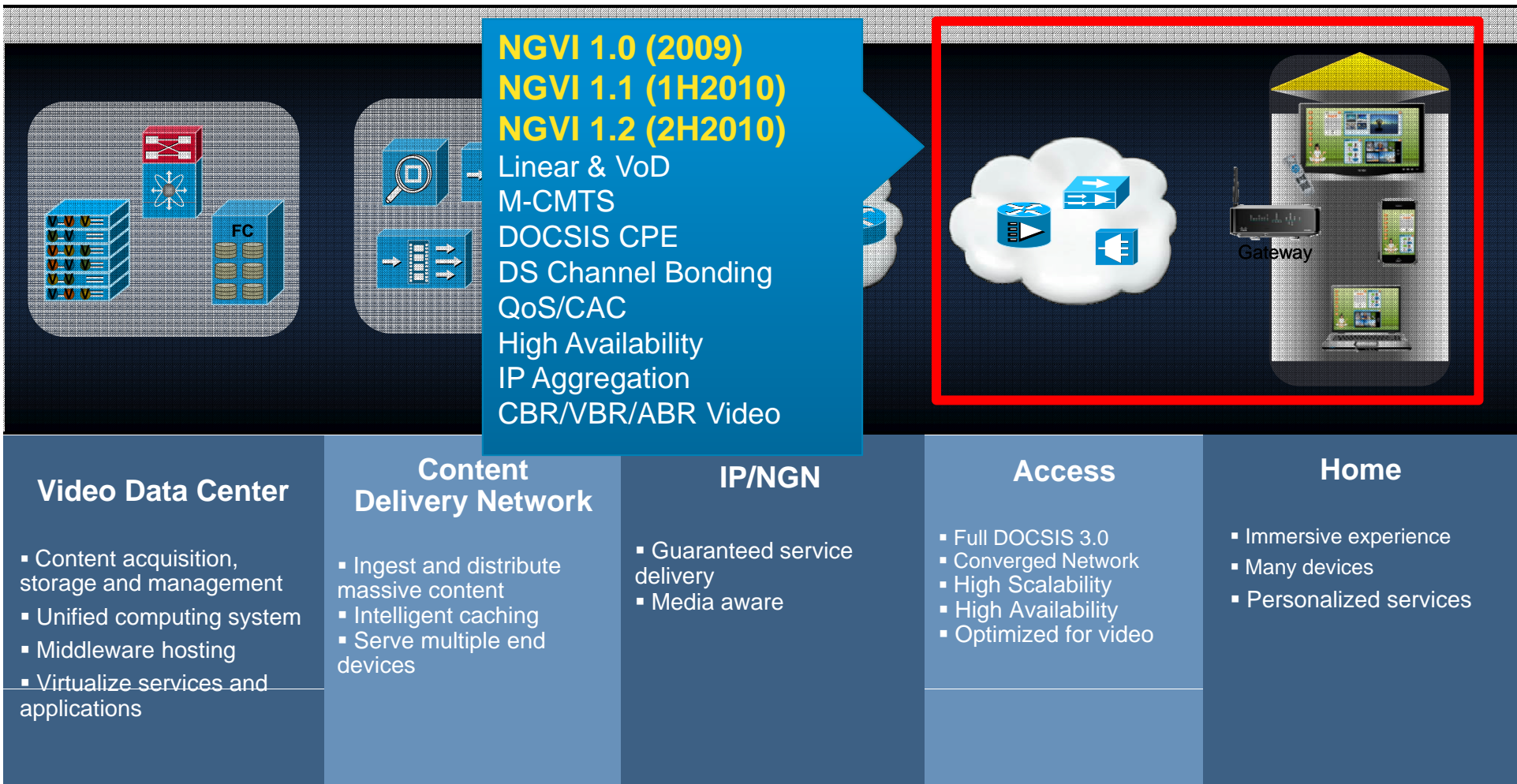

Next-generation Video Infrastructure (NGVI)

Modular and Middleware Independent

An All-IP Network for a New Generation of Interactive Services



Video Data Center	Content Delivery Network	IP/NGN	Access	Home
<ul style="list-style-type: none"> Content acquisition, storage and management Unified computing system Middleware hosting Virtualize services and applications 	<ul style="list-style-type: none"> Ingest and distribute massive content Intelligent caching Serve multiple end devices 	<ul style="list-style-type: none"> Guaranteed service delivery Media aware 	<ul style="list-style-type: none"> Full DOCSIS 3.0 Converged Network High Scalability High Availability Optimized for video 	<ul style="list-style-type: none"> Immersive experience Many devices Personalized services

Planning and Deployment Services



Cisco AS-Video Lifecycle Services Approach

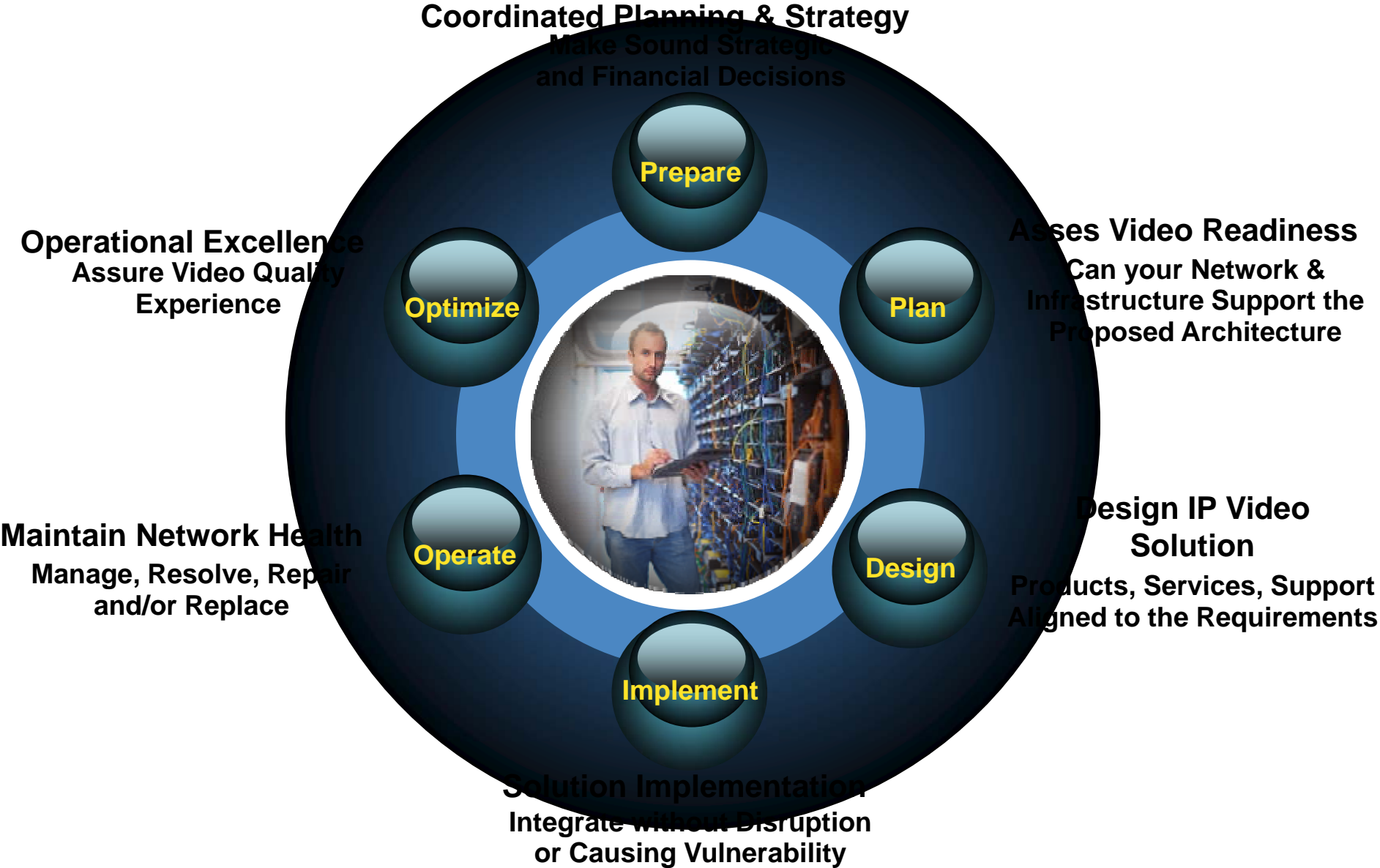

Cisco AS-Video Value Proposition

Solution focus as cornerstone of a Customer Intimacy strategy

- Solutions tailored to Market segments, Geography and Customers, based on Cisco E2E Reference architectures
- Ownership of Key Technology Partners to Implement & Support Turnkey Ecosystems
- Risk Mitigation by Leveraging Systems Integration Capability

End-to-End Systems Integration Capabilities

- Broad Video and IP Technology Expertise and Experience
- Experienced Program Management Organization, Capable to Deliver Complex E2E Solutions in Prime role.
- Customer Demo and POC labs, equipped with E2E Solutions: IP Video, Video over DOCSIS 3.0

Customer Case Study: Magyar Telekom



Magyar Telekom Overview

- Largest Fixed-line Service Provider in Hungary
 - ~700,000 TV subscribers
 - ~595,000 Broadband subscribers
- Copper/DSL, Fiber, Cable and Mobile Networks
- Cable Subscribers
 - ~400,000 Cable TV subscribers
 - ~161,000 Cable Broadband subscribers
- Currently offers T-Home IPTV Service with Microsoft Mediaroom IPTV System to DSL/Fiber subscribers
- Extending T-Home IPTV Service to cable subscribers with Cisco Video over EuroDOCSIS 3.0 solution
 - ~580,000 Households served by EuroDOCSIS 3.0

T-Home IPTV Services

Digital TV broadcast

- SD and HD TV channels
- Pay TV movie channels
- Mini-pay packages (thematic channels)
- Electronic program guide
- Quick channel change

Extra services

- Pause, rewind live TV
- One touch recording
- Remote programming through the web
- Background recording of another channel
- Picture in picture for channel change
- Media Share (PC to STB)

VideoTheque (VoD library)

- 500 movies
- Pay TV subscription based VoD
- Archive TV and fitness packages

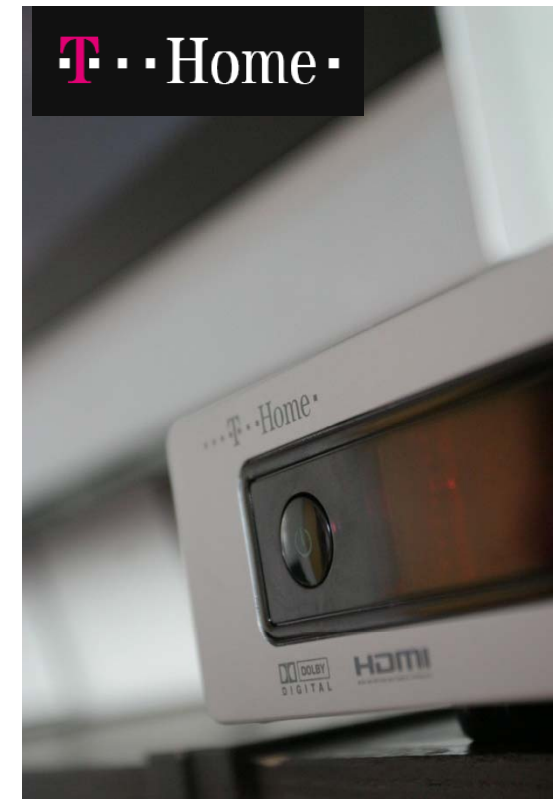

Magyar Telekom Cable IPTV System

First IPTV over DOCSIS 3.0 Deployment Worldwide



Sat Rx
SD/HD Encoder

Cisco Video Headend



**Microsoft Mediaroom
IPTV System**



CRS-1
7600

Cisco IP Network



uBR10012
CMTS

RF
Gateway

**Cisco EuroDOCSIS 3.0
Network**

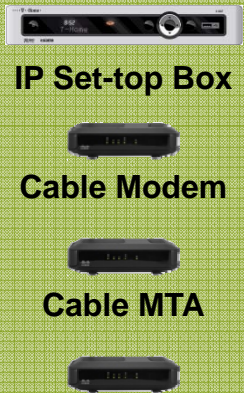

IP Set-top Box
Cable Modem
Cable MTA
Residential
Gateway

**Cisco Connected
Home**

Summary

- IP Video technology innovation is accelerating
- Cable IP Video enables delivery of more services to more devices with greater efficiency and faster time to market
- Cisco Video over DOCSIS 3.0 solutions enable efficient and cost-effective delivery of IP video services over DOCSIS
- Cisco Video over DOCSIS 3.0 solutions tested and available today



Connecting Customers with a New Generation of Cable Services

Cisco Knowledge Network for Cable



- **Join the Cisco Knowledge Network Community**

Send an email to: ckncable@external.cisco.com

Subject: **Subscribe**



- We value your feedback, please complete the survey
- July 20th session will cover “Return Path Trouble Shooting”

